

# E5T

Le très compact E5T a été développé pour fournir un transfert thermique maximal dans des applications de chaudières murales sans condensation. Cet assemblage, avec plaques avant et arrière intégrées, permet d'utiliser les plaques de recouvrement pour transférer la chaleur et bénéficier d'un meilleur rapport coût-rendement.



## Spécifications de base

Nombre de plaques max. (NoP)	48
Débit volumétrique max.	4 m <sup>3</sup> /h (17.61 gpm)
Volume du canal	0.024/0.024 dm <sup>3</sup> (0.0008/0.0008 ft <sup>3</sup> )
Matières	Plaques en acier inoxydable 316, brasage cuivre
Poids sans les connexions	0.29+(0.044*NoP) kg 0.63+(0.097*NoP) lb

## Les dimensions standard

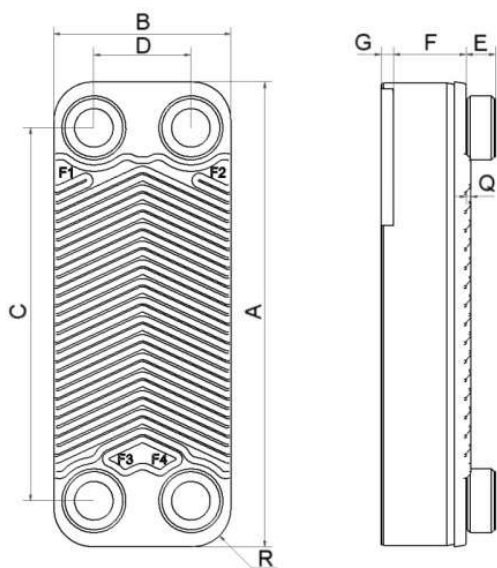

#	MM	IN
A	192	7.56
B	73	2.87
C	154	6.06
D	40	1.57
F	2.00+(2.24*(NoP-2.00))	0.08+(0.09*(NoP-0.08))
G	7	0.28
Q	2	0.08
R	16	0.63
E_1	12	0.47

## PED pression / température

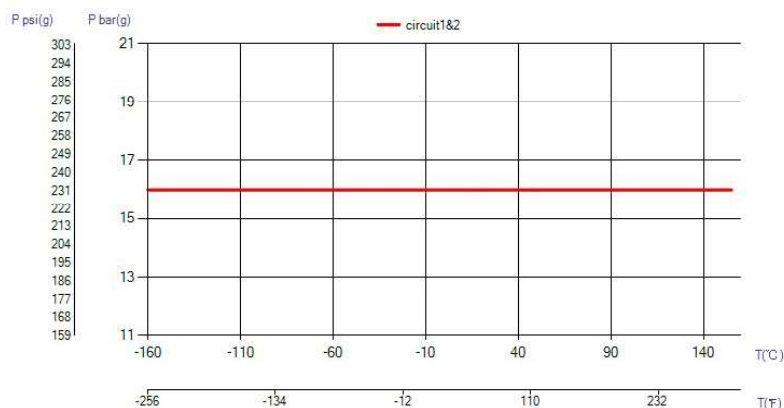

# AXINTRA

ÉCHANGEURS THERMIQUES

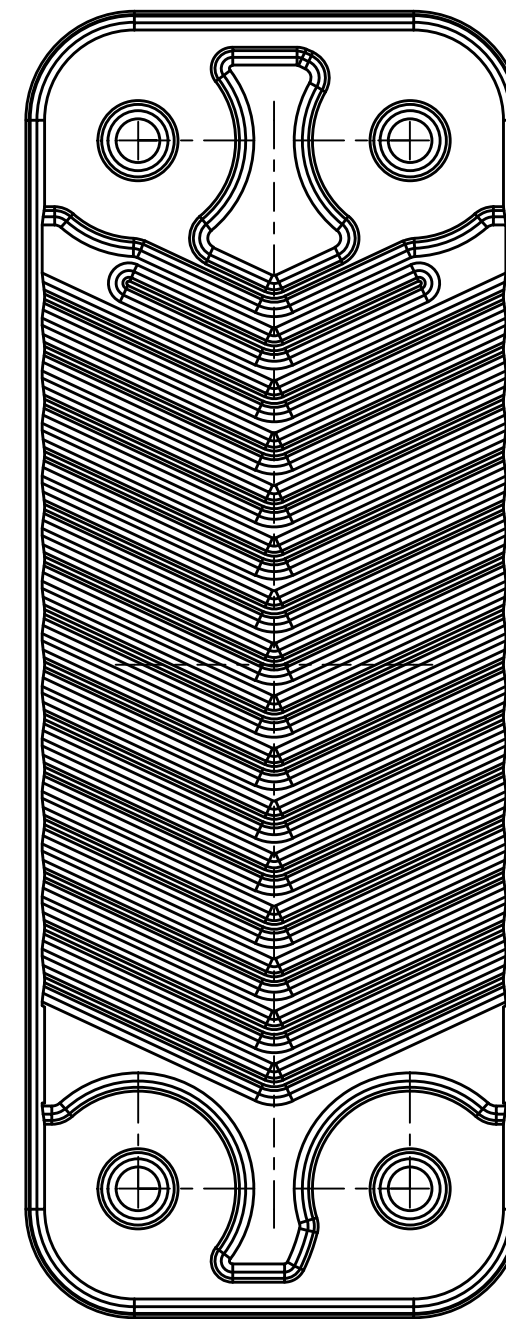
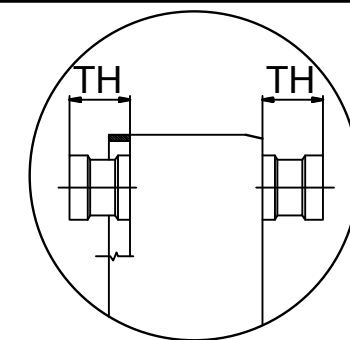
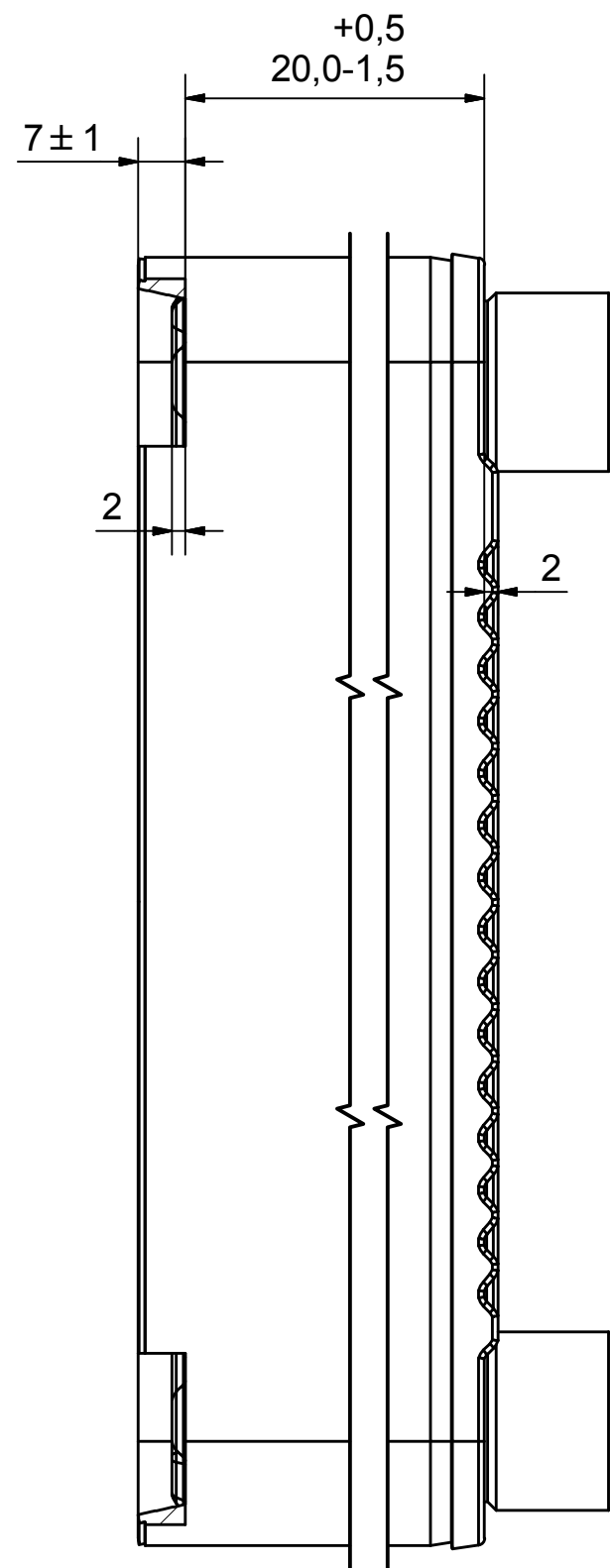
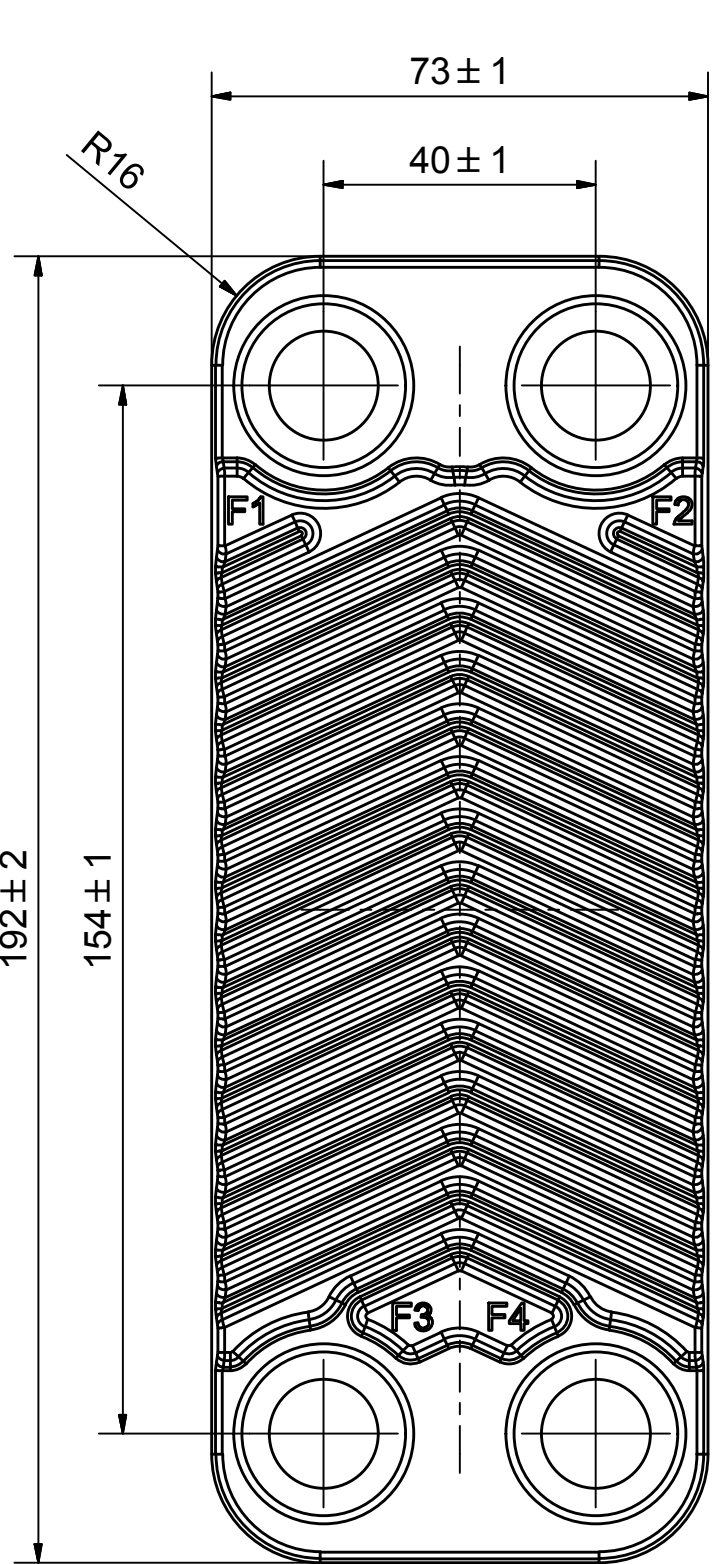

© Company Confidential, Property of SWEP International AB

**AXINTRA**  
ÉCHANGEURS THERMIQUES

F4	46302	ISO-G 3/4, TH = 20,1	CD000313
F3	46302	ISO-G 3/4, TH = 20,1	CD000313
F2	46302	ISO-G 3/4, TH = 20,1	CD000313
F1	46302	ISO-G 3/4, TH = 20,1	CD000313

Pos	Article No	Title / Denomination, code, material, dimension etc	Drawing No./ref	Pos	Article No	Title / Denomination, code, material, dimension etc	Drawing No./ref
-----	------------	---	-----------------	-----	------------	---	-----------------

Title		<b>E5TH/1P-SC-S</b>	
		Created Date	Created By
A DOVER COMPANY		2018-03-05	AU
		Article/Configuration number	Drawing number
		18056-010	AU00355028

Rev No.	Alteration	Date	Checked	Approved
8	DEBURRING INFO ADDED	2009/03/09	TL	PDM

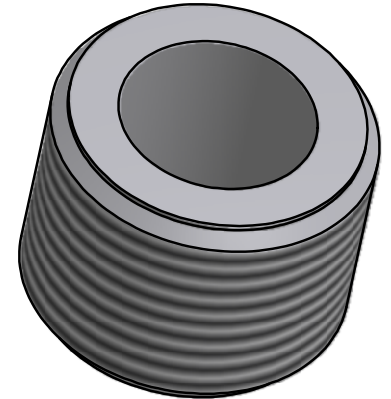
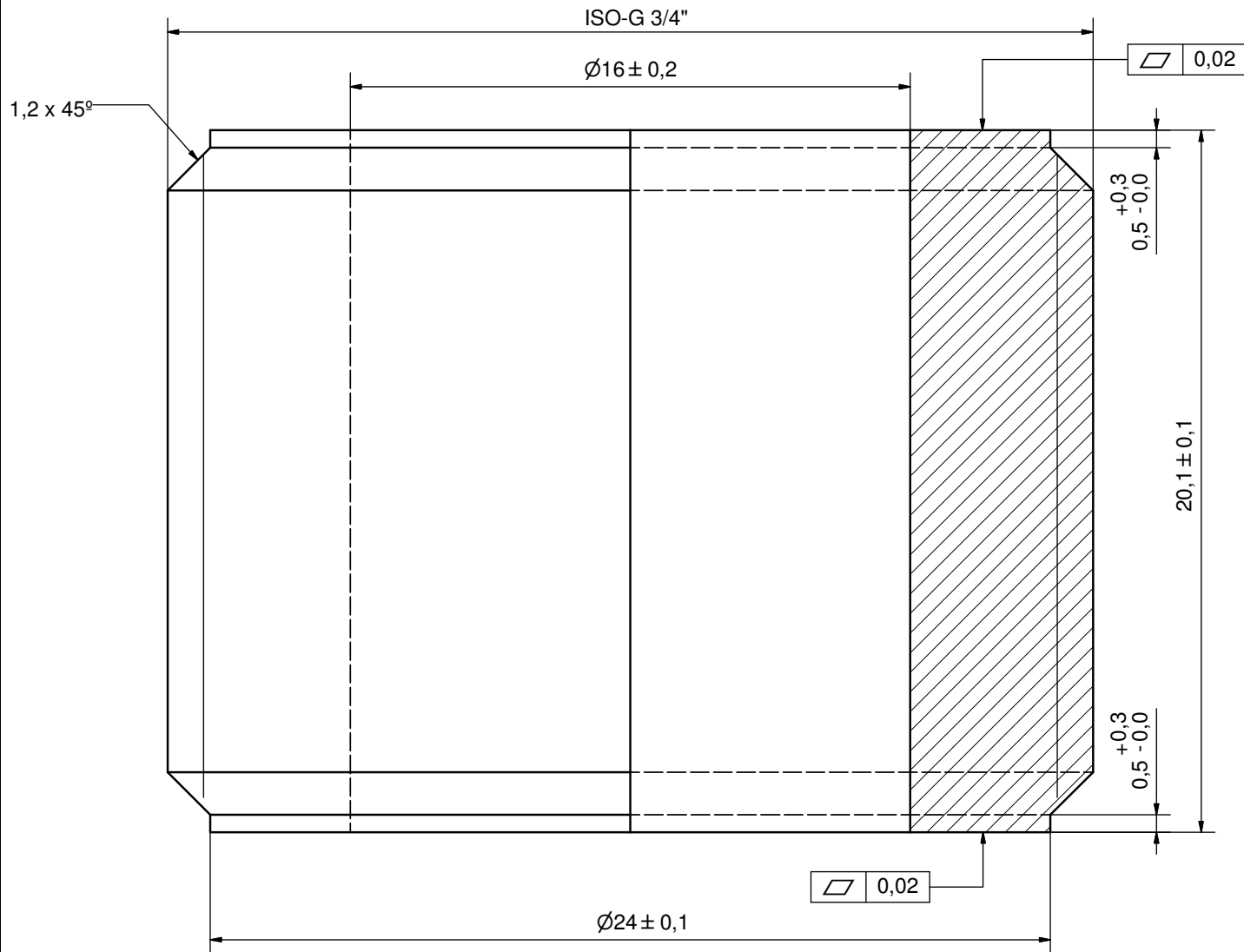

© Company Confidential. Property of SWEP International AB

**AXINTRA**  
ÉCHANGEURS THERMIQUES

**DEBURR SHARP EDGES; MAX 0,4**

ACCORDING TO MQS  
MATERIAL

Drawn	Checked	Approved	Created Date	General geometrical tolerancing ISO 2768	General surface finish $R_a$	Scale
JA	TOD	BOS	1996-12-05	3.2	$\varnothing$	-
<b>SWEP</b> A DOVER COMPANY				Title <b>ISO-G 3/4</b>		
Article number		Drawing number		Revision	Sheet	
-		CD000313		8	1 (1)	