

B4T

La demande en réfrigérants naturels tels que le CO2 augmente également pour les faibles puissances. Pour des applications au CO2 transcritique nécessitant des pressions approchant 140 bar, le B4TU se présente comme un choix évident. Le B4TU est optimisé pour des puissances de refroidissement de gaz faibles (jusqu'à 30 kW en tant que refroidisseur de gaz). Sa compacité et sa légèreté le rendent adapté aux applications de la chaîne du froid (condenseur dans un circuit d'eau fermé, économiseur et condenseur dans les unités de condensation, récupération de chaleur) et aux pompes à chaleur (évaporateurs, refroidisseurs de gaz, échangeurs thermiques à aspiration de gaz).



Spécifications de base

| | |
|--------------------------------------|----------------------------------------------------------------|
| Nombre de plaques max. (NoP) | 100 |
| Débit volumétrique max. | 1,2 m ³ /h (8.81 gpm) |
| Volume du canal | 0.0093/0.0093 dm ³ (0.0003/0.0003 ft ³) |
| Matières | Plaques en acier inoxydable 304, brasage cuivre |
| Poids sans les connexions | 0.82+(0.04*NoP) kg 1.81+(0.088*NoP) lb |
| Taille la taille des Particules (mm) | 0,4 |

Les dimensions standard

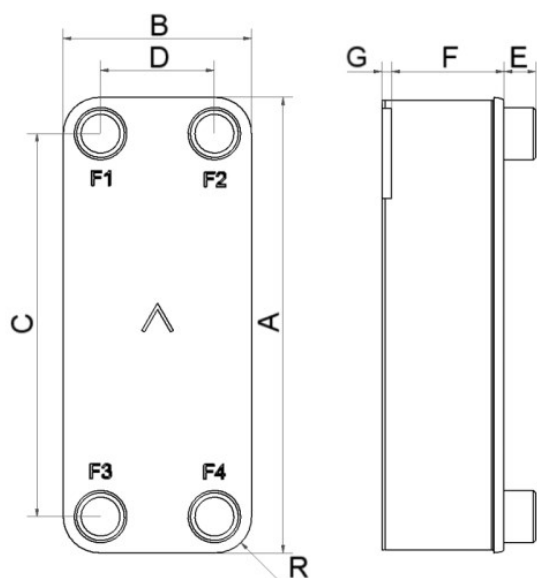

| # | MM | IN |
|-----|-----------------|-----------------|
| A | 194.50 | 7.66 |
| B | 76.90 | 3.03 |
| C | 154 | 6.06 |
| D | 40 | 1.57 |
| F | 8,00+1,06*(NoP) | 0.31+0.04*(NoP) |
| G | 4 | 0.16 |
| R | 18 | 0.71 |
| E_1 | 20 | 0.79 |

PED pression / température

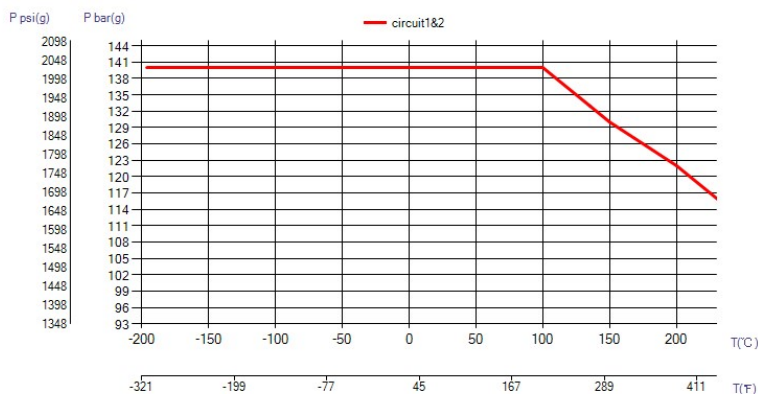

ÉCHANGEURS THERMIQUES

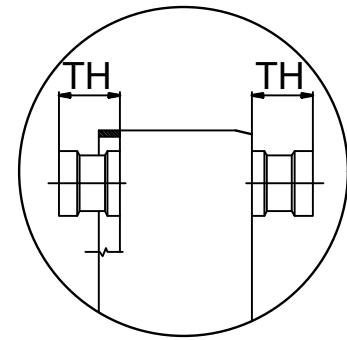
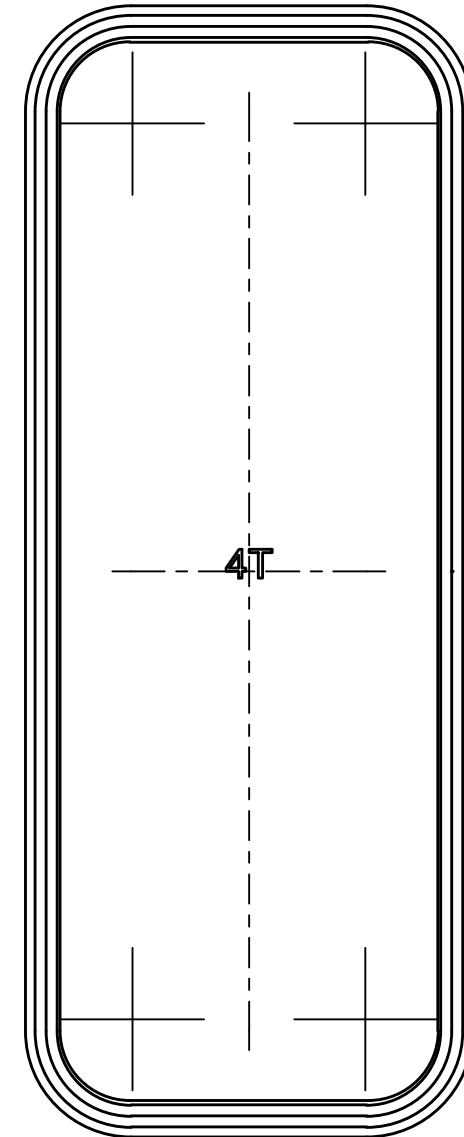
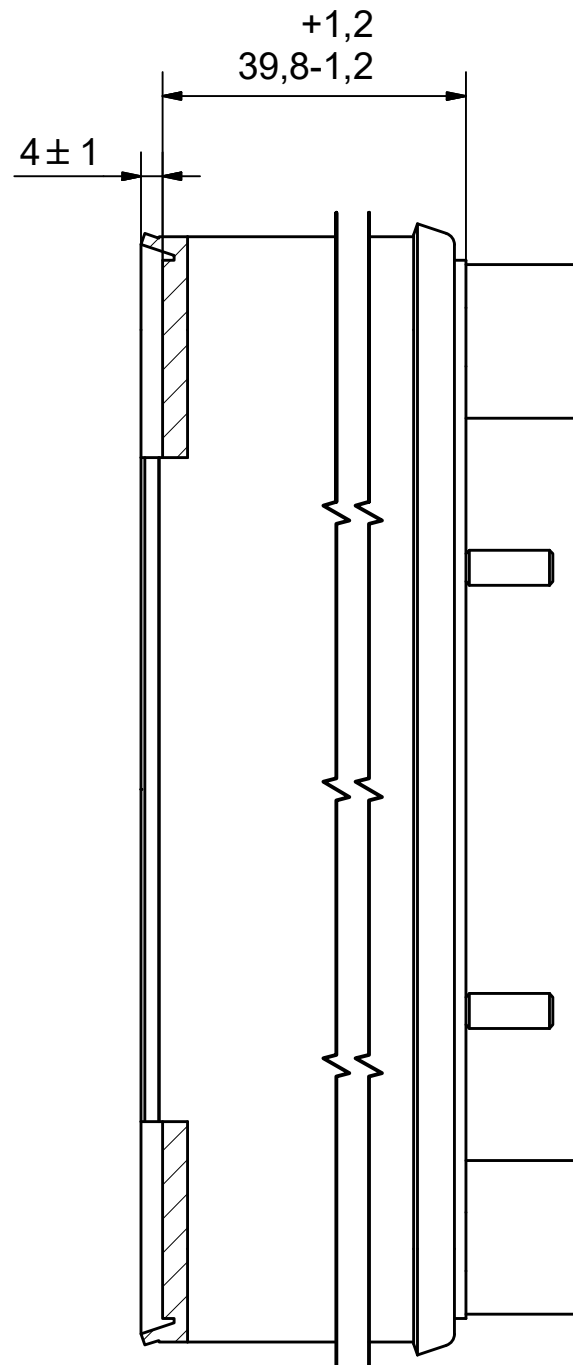
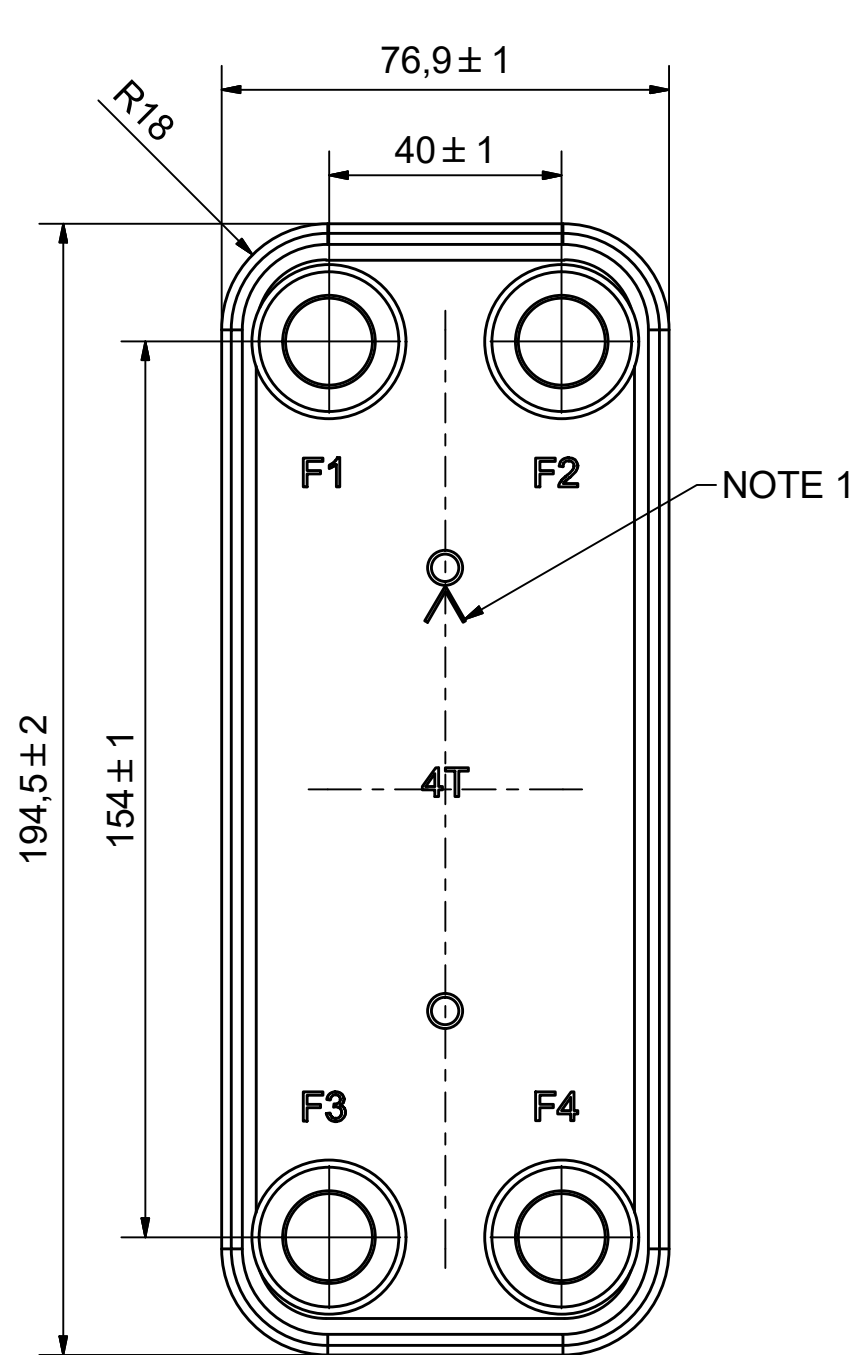

AXINTRA
ÉCHANGEURS THERMIQUES

NOTE 1 ALTERNATE MARKING: STICKER OR STAMP

| | | | |
|----|-------|------------------------------------|------------|
| F4 | 32835 | ISO-G 3/4" & SOLDER 16, TH = 20,1 | CD000859 |
| F3 | 32835 | ISO-G 3/4" & SOLDER 16, TH = 20,1 | CD000859 |
| F2 | 32835 | ISO-G 3/4" & SOLDER 16, TH = 20,1 | CD000859 |
| F1 | 32835 | ISO-G 3/4" & SOLDER 16, TH = 20,1 | CD000859 |
| F | 24002 | 4 STUD BOLT LOC. F 2x 76.2 (M6x15) | 00040463_1 |

| Pos | Article No | Title / Denomination, code, material, dimension etc | Drawing No./ref | Pos | Article No | Title / Denomination, code, material, dimension etc | Drawing No./ref |
|-----|------------|-----------------------------------------------------|-----------------|-----|------------|-----------------------------------------------------|-----------------|
|-----|------------|-----------------------------------------------------|-----------------|-----|------------|-----------------------------------------------------|-----------------|

| | | | |
|----------------------------------------------------------------------------------------------------------|------------------------------|------------------------------|----------------|
| Title | | B4 THx30/1P-NC-U 4x3/4" & 16 | |
|  A DOVER COMPANY | Created Date | 2023-03-24 | Created By |
| | Article/Configuration number | 0292484.0 | Drawing number |
| | | AU | |
| | | AU00739210_0292484.0 | |

| Rev No | Alteration | Date | Checked | Approved |
|--------|------------|------|---------|----------|
| 00 | | | | PDM |

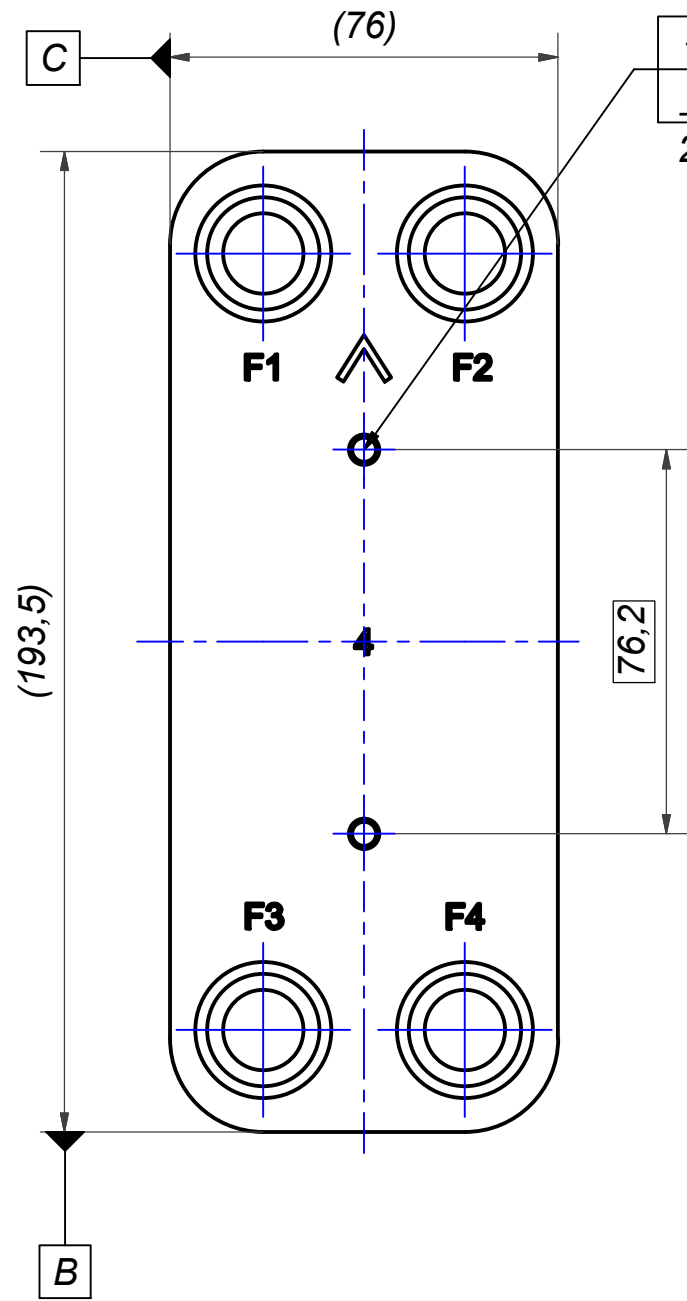
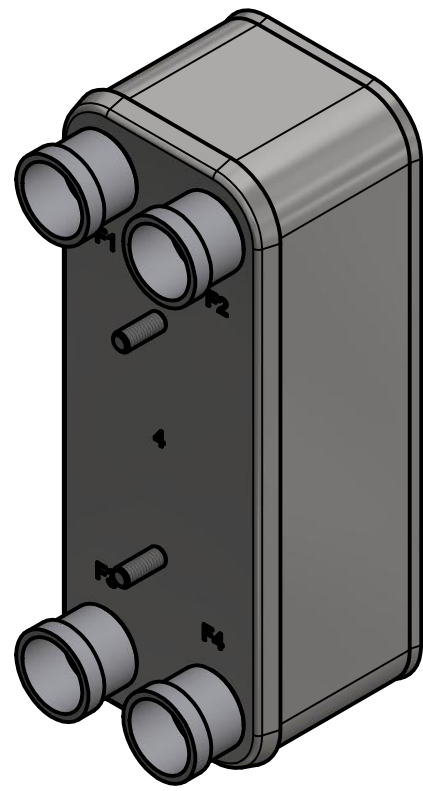

| | | | | |
|---------------|-------------------|---|---|---|
| \varnothing | $\varnothing 1$ | A | B | C |
| \perp | $\varnothing 0.4$ | A | | |
| 2x | | | | |

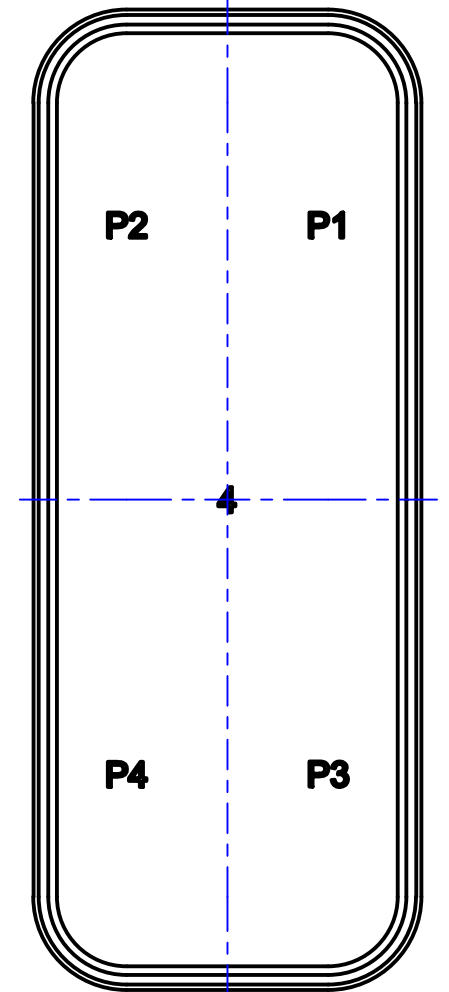
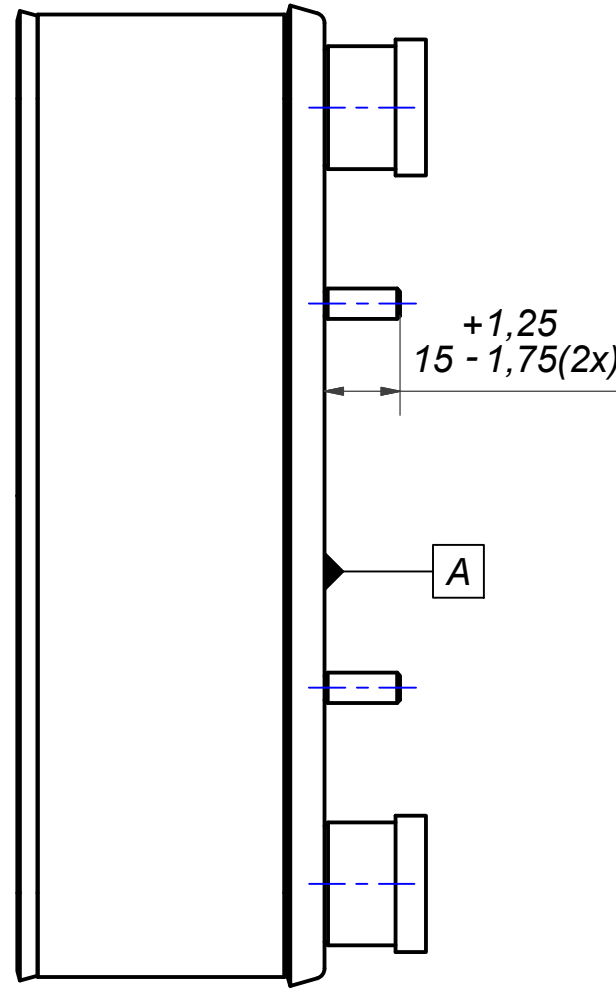

© Company Confidential, Property of SWEP International AB

AXINTRA
ÉCHANGEURS THERMIQUES

SWEP
A DOVER COMPANY

| | | | | | | | |
|-------|---------|------------------------------------|--------------|-------------------------------------------|--------------------------------|-------------------|------------|
| 2 | 1 | STUD BOLT M6x15 ART.NO. 30235 | | | | M6x15 | |
| Item | QTY | Description | | | | Drawing / Article | |
| Drawn | Checked | Approved | Created Date | General geometrical tolerancing ISO 2768: | General surface finish R_a : | Scale | Paper size |
| cnvg | PDM | PDM | 3/29/2018 | | | \varnothing | A3 |
| | | Title | | | | | |
| | | 4 STUD BOLT LOC. F 2x 76.2 (M6x15) | | | | | |
| | | Article number | Design Type | Drawing number | Revision | Sheet | |
| | | 24002 | CG | 00040463 | 00 | 1 (1) | |

| Rev No. | Alteration | Date | Checked | Approved |
|---------|------------------------|------------|---------|----------|
| 1 | CHANGED INNER DIAMETER | 2007/09/17 | ANL | PDM |

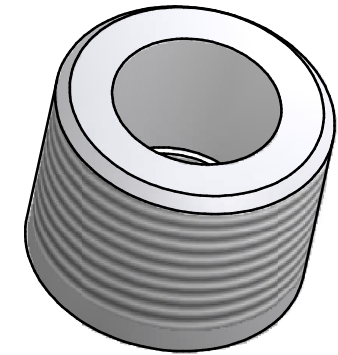
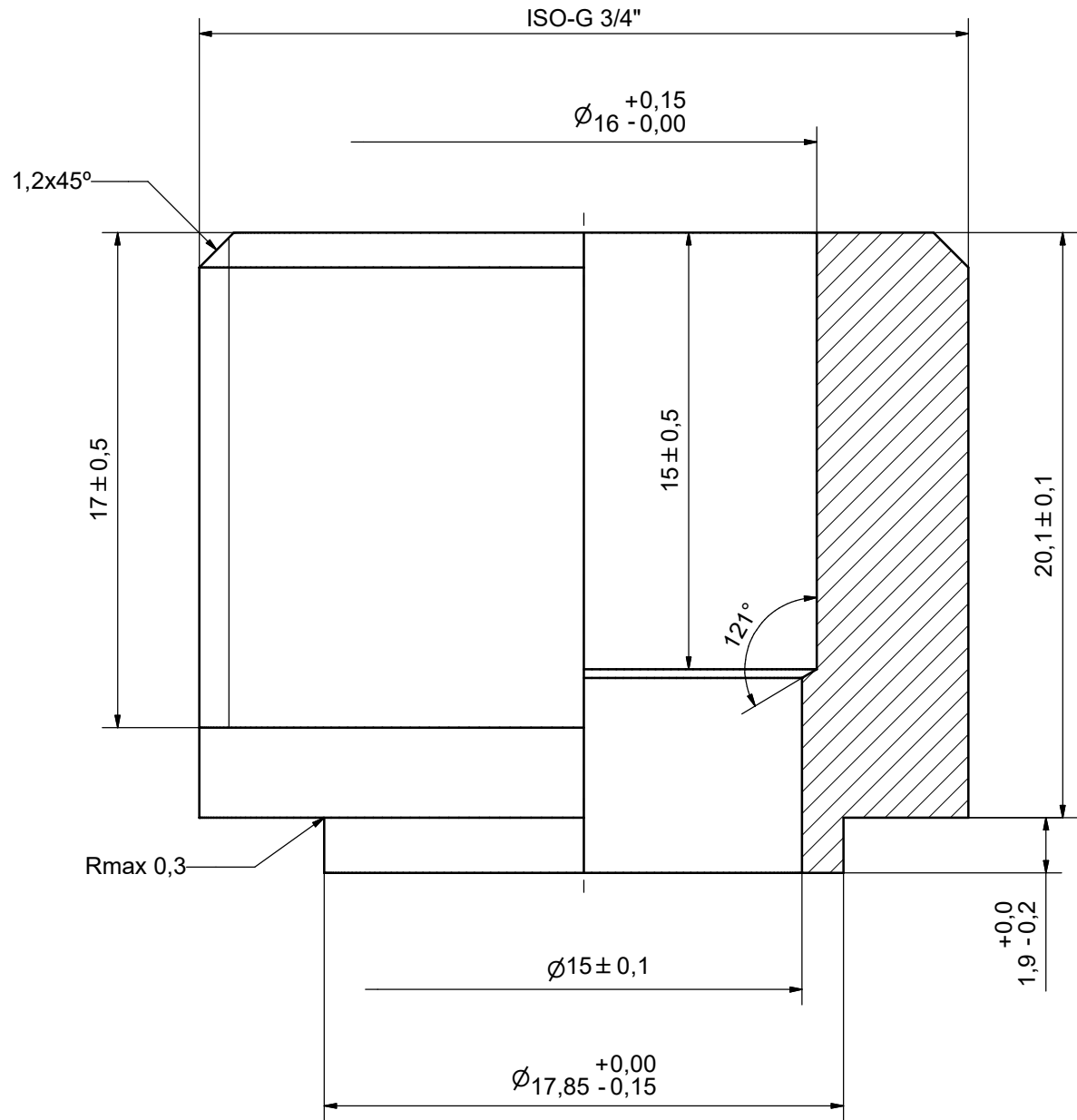

© Company Confidential, Property of SWEP International AB

AXINTRA
ÉCHANGEURS THERMIQUES

| Drawn | | Checked | | Approved | | Created Date | | General geometrical tolerancing ISO 2768 | | General surface finish R_a | | Scale | | | |
|----------------|--|---------|--|----------|--|----------------|--|------------------------------------------|--|------------------------------|--|------------------------|--|-------|--|
| ANL | | PDM | | PDM | | 2007/04/25 | | m | | 3.2 | | 5:1 | | | |
| Title | | | | | | | | | | | | ISO-G 3/4" & SOLDER 16 | | | |
| Article number | | | | | | Drawing number | | | | | | Revision | | Sheet | |
| - | | | | | | CD000859 | | | | | | 1 | | 1 (1) | |

ACCORDING TO MQS
MATERIAL

