

# BX8T

Le BX8T à marque X est un bon choix pour diverses applications à une et deux phases, dans de nombreux secteurs industriels. Son transfert thermique efficace convient bien aux exigences d'applications diverses, telles que les pompes à chaleur et la réfrigération des conteneurs. Les plaques X à l'avant et l'arrière apportent une stabilité structurelle et servent également de plaques de transfert thermique actives. Ce système de plaques toutes actives maximise l'utilisation des matériaux et confère au produit un rendement et une compétitivité adaptés aux applications exigeantes.

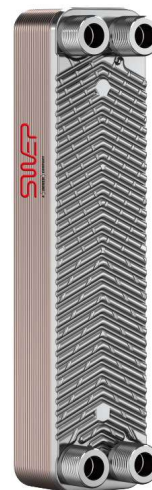

## Spécifications de base

Nombre de plaques max. (NoP)	60
Débit volumétrique max.	4 m <sup>3</sup> /h (17.61 gpm)
Volume du canal	0.039/0.039 dm <sup>3</sup> (0.0014/0.0014 ft <sup>3</sup> )
Matières	Plaques en acier inoxydable 316, brasage cuivre
Poids sans les connexions	0.53+(0.075*NoP) kg 1.16+(0.165*NoP) lb

## Les dimensions standard

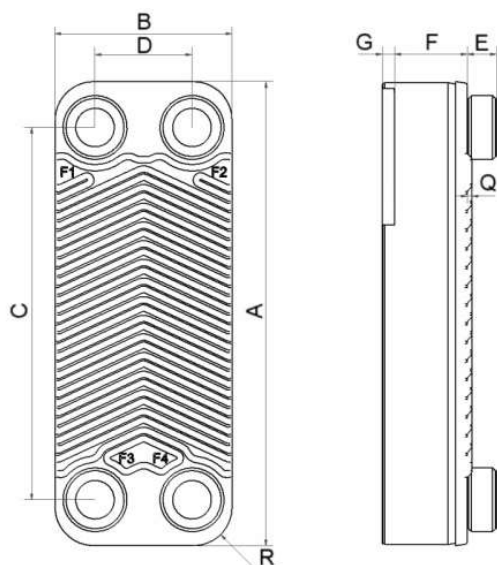

#	MM	IN
A	315	12.4
B	73	2.87
C	278	10.94
D	40	1.57
F	2.00+(2.24*(NoP-2.00))	0.08+(0.09*(NoP-0.08))
G	7	0.28
Q	2	0.08
R	16	0.63
E_1	20	0.79

## PED pression / température

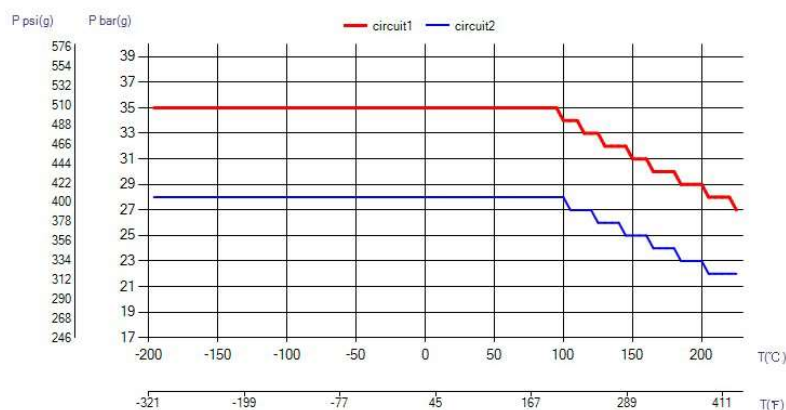
**AXINTRA**

ÉCHANGEURS THERMIQUES

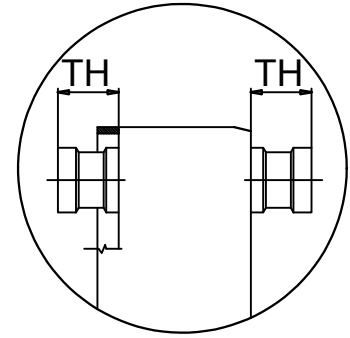
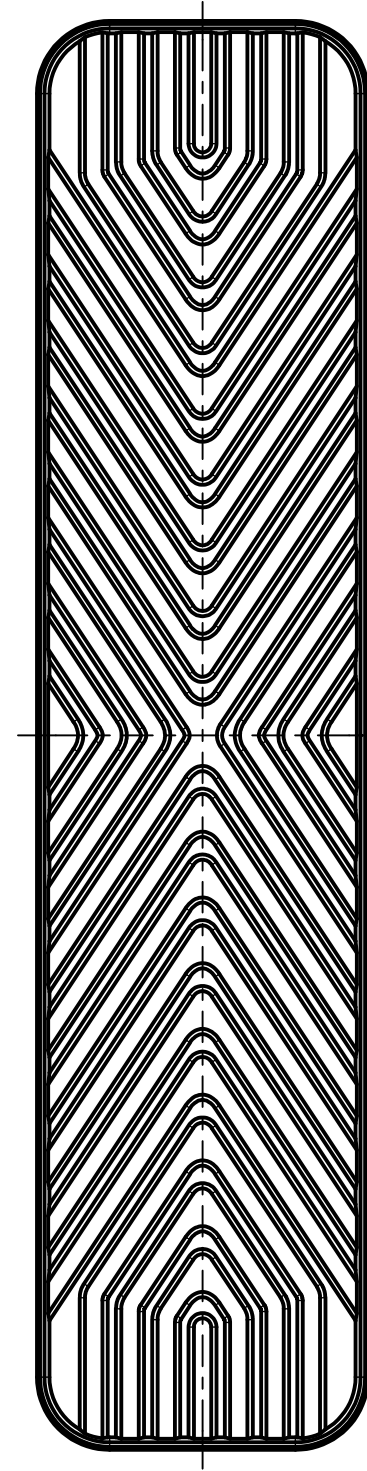
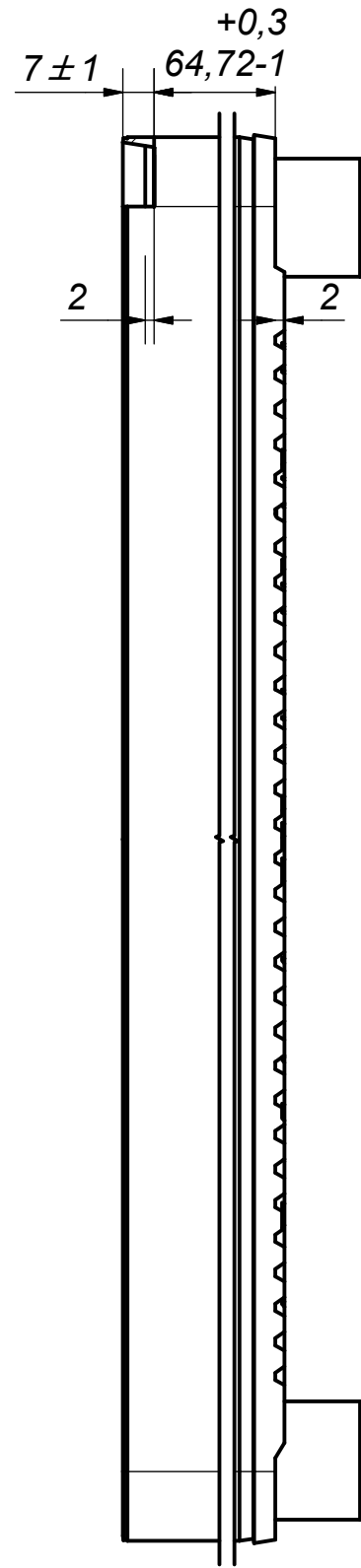
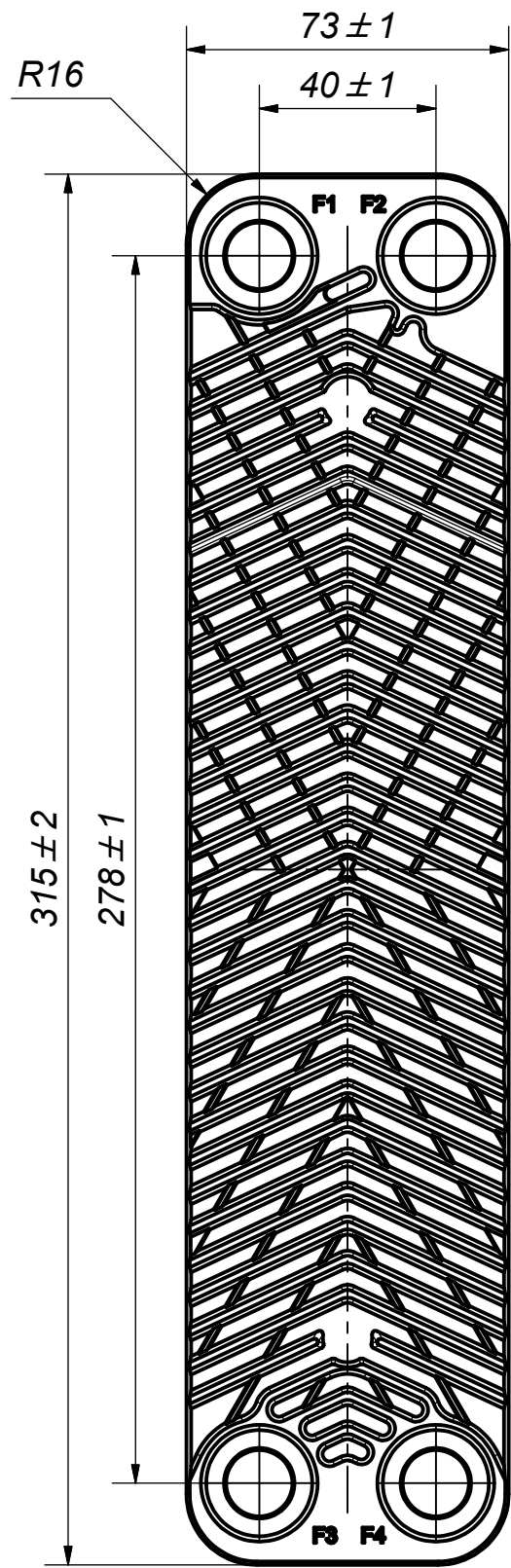

**AXINTRA**  
ÉCHANGEURS THERMIQUES

F4	34380	ISO-G 3/4" & Solder 16, TH = 20.1	CD001108
F3	34380	ISO-G 3/4" & Solder 16, TH = 20.1	CD001108
F2	34380	ISO-G 3/4" & Solder 16, TH = 20.1	CD001108
F1	34380	ISO-G 3/4" & Solder 16, TH = 20.1	CD001108

Pos	Article No	Title / Denomination, code, material, dimension etc	Drawing No./ref	Pos	Article No	Title / Denomination, code, material, dimension etc	Drawing No./ref
-----	------------	---	-----------------	-----	------------	---	-----------------

Title		BX8THx30/1P-SC-S 4x3/4"&16	
 <b>DOVER COMPANY</b>	Created Date	2012-07-03	Created By
	Article/Configuration number	14314-30	Drawing number
			AU
			AU00082787

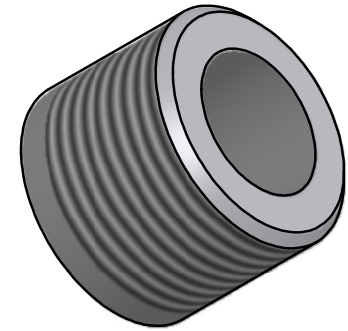
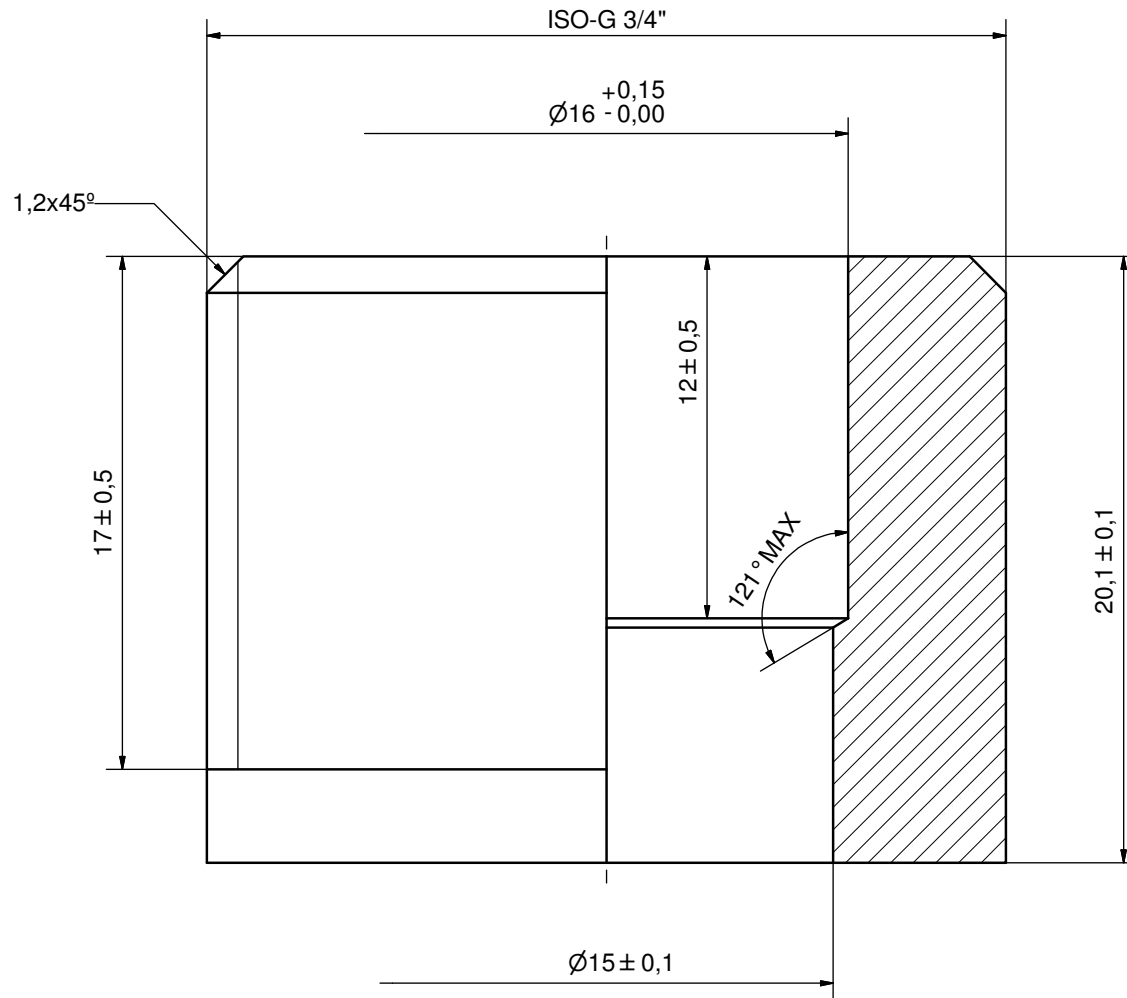

DEBURR SHARP EDGES; MAX 0,4

ACCORDING TO MQS

MATERIAL

Drawn	Checked	Approved	Created Date	General geometrical tolerancing ISO 2768	General surface finish $R_a$	Scale
AP	PDM	PDM	2009-05-04	m	3.2	-
			Title <b>ISO-G 3/4" &amp; Solder 16</b>			
Article number		Drawing number		Revision	Sheet	
-		CD001108		-	1 (1)	