

B8LAS

Le compact B8LAS est un produit conçu pour associer des performances thermiques élevées à de faibles pertes de charges. Grâce à sa géométrie de plaques dotée de la technologie AsyMatrix®, cet échangeur offre des solutions efficaces et polyvalentes pour les pompes à chaleur haute performance et les applications de réfrigération.



Spécifications de base

Nombre de plaques max. (NoP)	70
Débit volumétrique max.	4 m ³ /h (17.61 gpm)
Volume du canal	0.0204/0.024 dm ³ (0.0007/0.0008 ft ³)
Matières	Plaques en acier inoxydable 316, brasage cuivre
Poids sans les connexions	0.84+(0.059*NoP) kg 1.85+(0.130*NoP) lb

Les dimensions standard

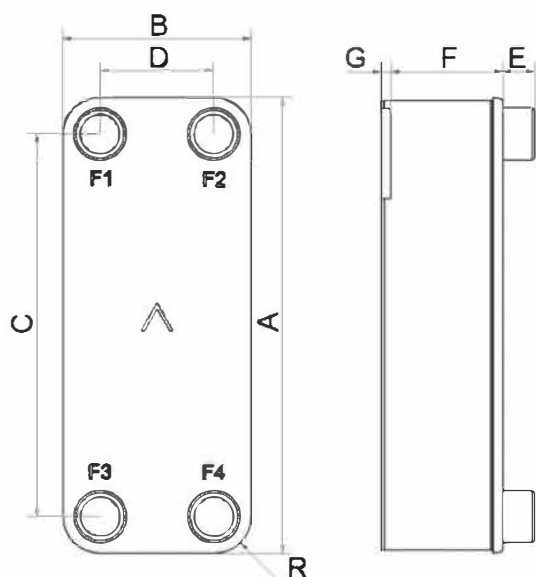

#	MM	IN
A	317.70	12.51
B	76.20	3
C	278	10.94
D	40	1.57
F	4.00+1.32*(NoP)	0.16+0.05*(NoP)
G	6.30	0.25
R	18	0.71
E_1	20	0.79

PED pression / température

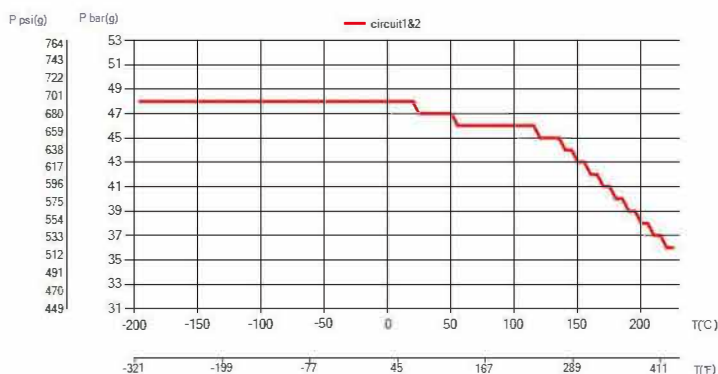

AXINTRA

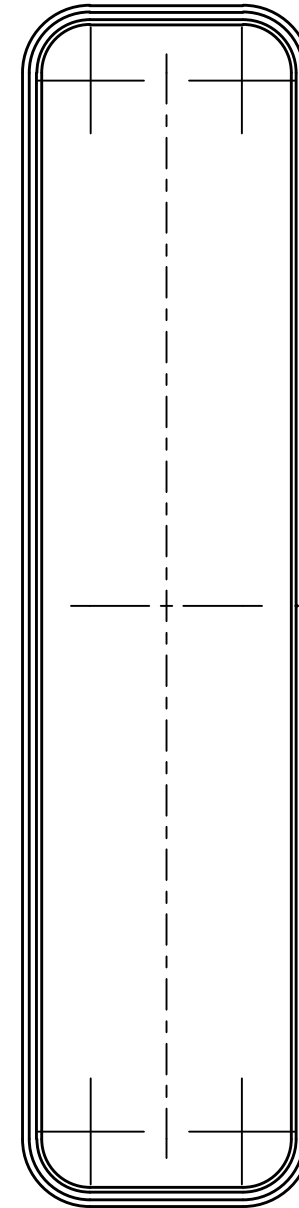
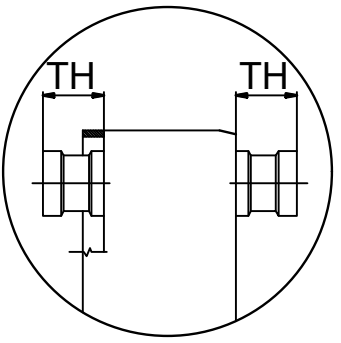
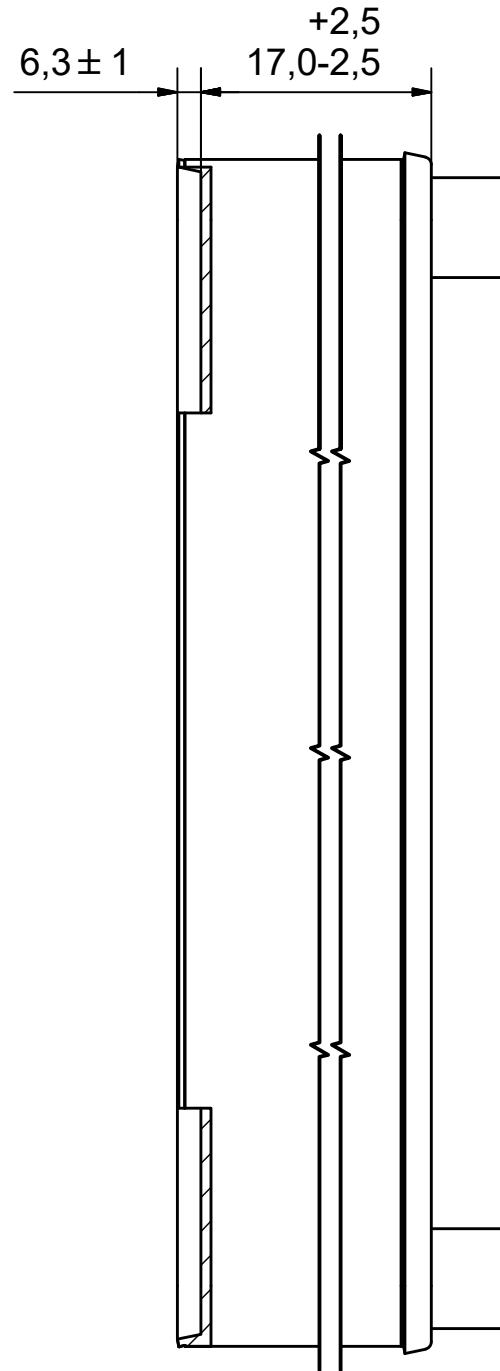
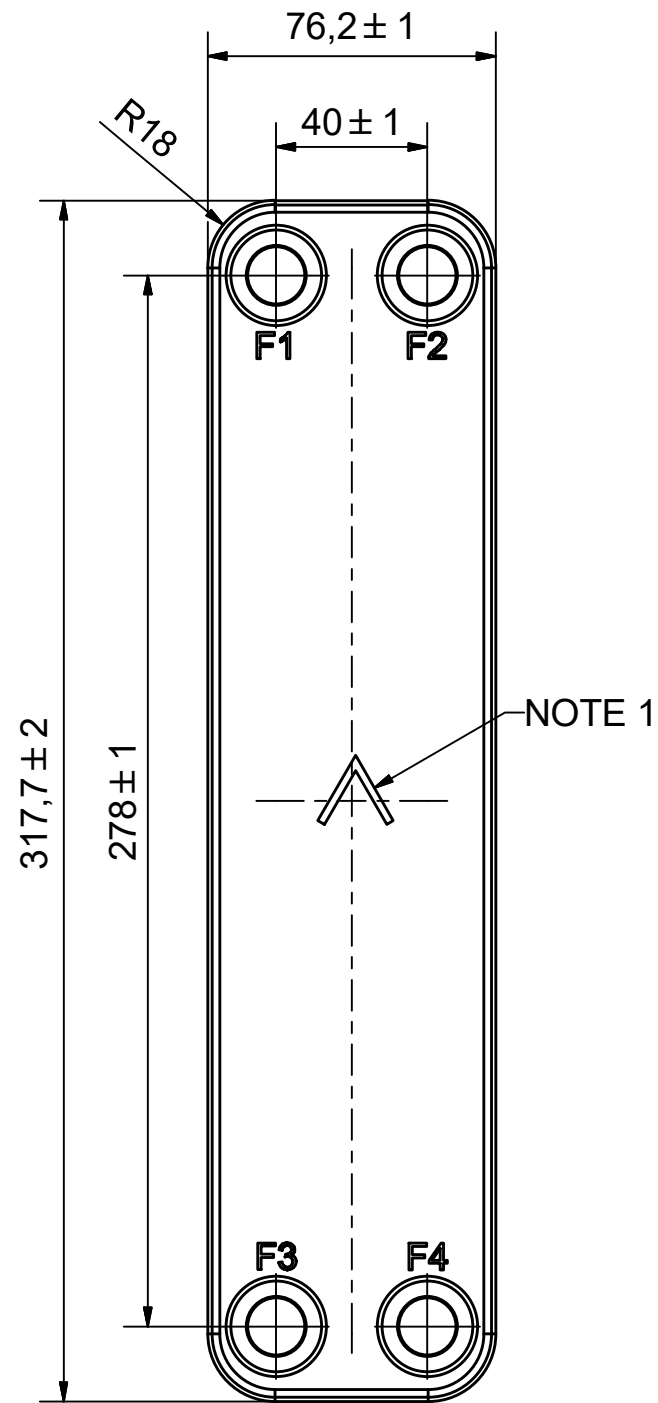

ÉCHANGEURS THERMIQUES



AXINTRA
ÉCHANGEURS THERMIQUES

NOTE 1 ALTERNATE MARKING: STICKER OR STAMP

F4	32835	ISO-G 3/4" & SOLDER 16, TH = 20,1	CD000859
F3	32835	ISO-G 3/4" & SOLDER 16, TH = 20,1	CD000859
F2	32835	ISO-G 3/4" & SOLDER 16, TH = 20,1	CD000859
F1	32835	ISO-G 3/4" & SOLDER 16, TH = 20,1	CD000859

Title		B8LASH/1P-SC-M	
 A DOVER COMPANY	Created Date	Created By	
	2019-01-21	AU	
	Article/Configuration number	Drawing number	
	16435-010	AU00452891	

Pos	Article No	Title / Denomination, code, material, dimension etc	Drawing No./ref	Pos	Article No	Title / Denomination, code, material, dimension etc	Drawing No./ref
-----	------------	-----------------------------------------------------	-----------------	-----	------------	-----------------------------------------------------	-----------------

Rev No.	Alteration	Date	Checked	Approved
1	CHANGED INNER DIAMETER	2007/09/17	ANL	PDM

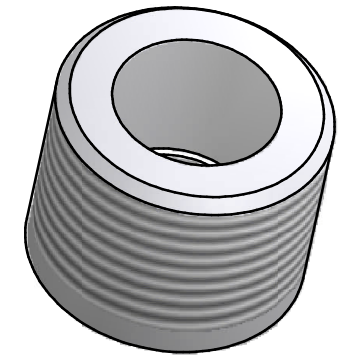
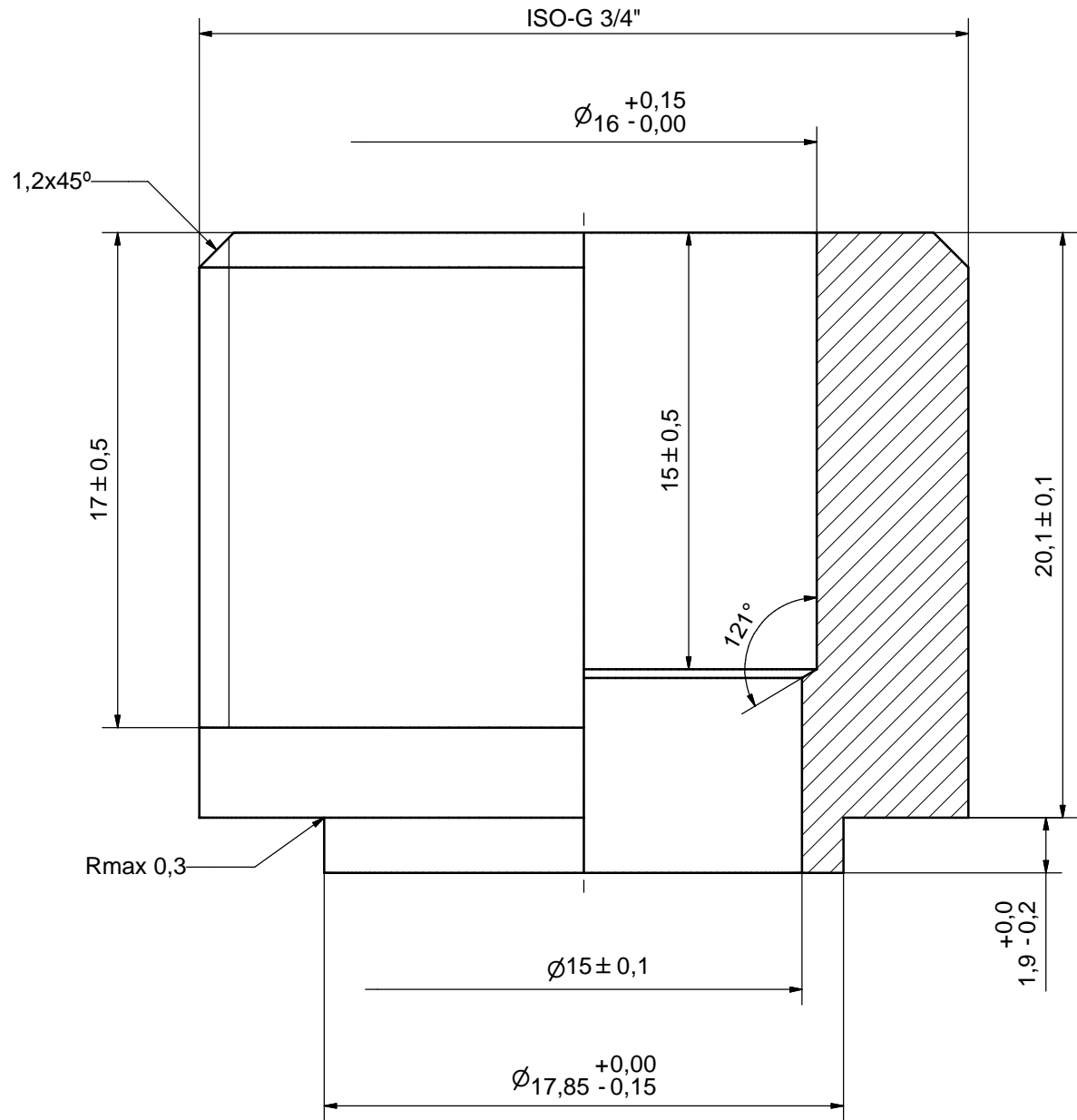

ACCORDING TO MQS
MATERIAL

Drawn	Checked	Approved	Created Date	General geometrical tolerancing ISO 2768	General surface finish R_a	Scale
ANL	PDM	PDM	2007/04/25	m	3.2	5:1
SUPER Title: ISO-G 3/4" & SOLDER 16						
Article number		Drawing number		Revision		Sheet
-		CD000859		1		1 (1)

© Company Confidential, Property of SWEP International AB

AXINTRA
ÉCHANGEURS THERMIQUES

