

B10TS- All Stainless

Le modèle B10TS propose des solutions d'échange thermique pour une large fourchette de capacités. Son adaptation à de nombreuses applications est rapide et simple. Les dimensions compactes de ce modèle, sa polyvalence et son excellent transfert thermique en font un choix idéal pour les applications à une phase et de réfrigération.



Spécifications de base

Nombre de plaques max. (NoP)	140
Débit volumétrique max.	9 m ³ /h (39.63 gpm)
Volume du canal	0.061/0.061 dm ³ (0.0022/0.0022 ft ³)
Matières	Plaques en acier inoxydable 316, brasage acier inoxydable
Poids sans les connexions	1.24+(0.121*NoP) kg 2.73+(0.267*NoP) lb

Les dimensions standard

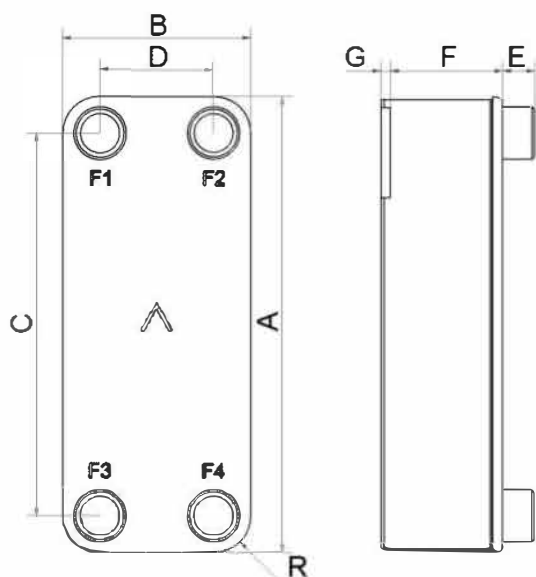

#	MM	IN
A	289	11.38
B	119	4.69
C	243	9.57
D	72	2.83
F	4.00+2.39*(NoP)	0.16+0.09*(NoP)
G	6	0.24
R	23	0.91
E_1	20	0.79

PED pression / température

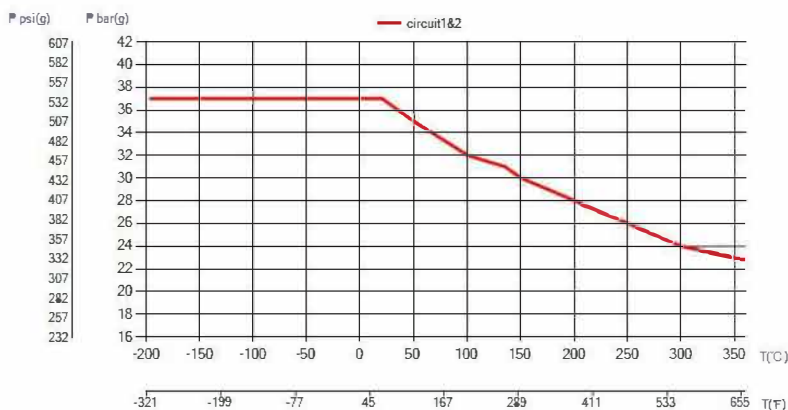

AXINTRA

ÉCHANGEURS THERMIQUES

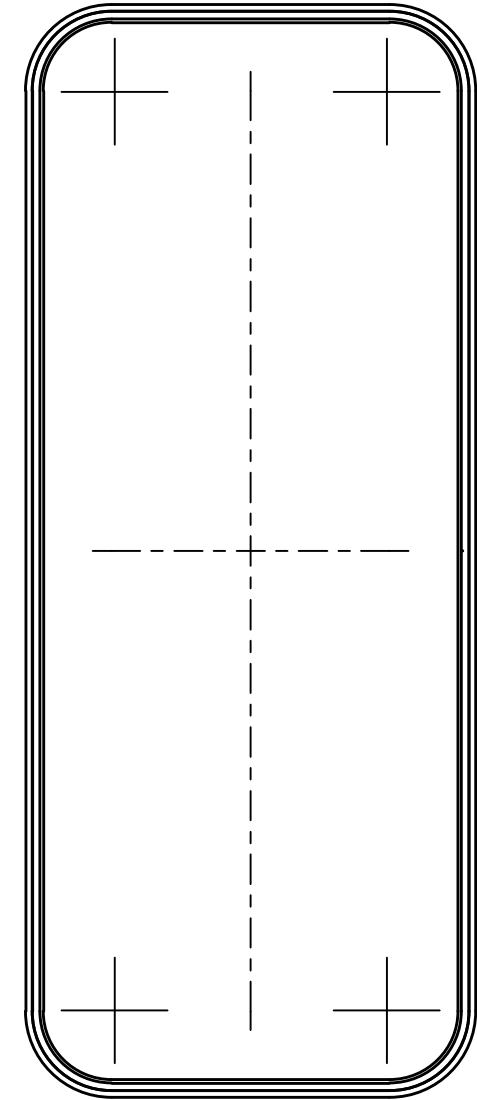
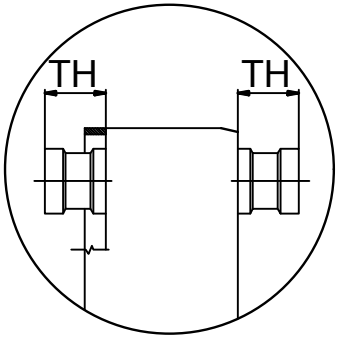
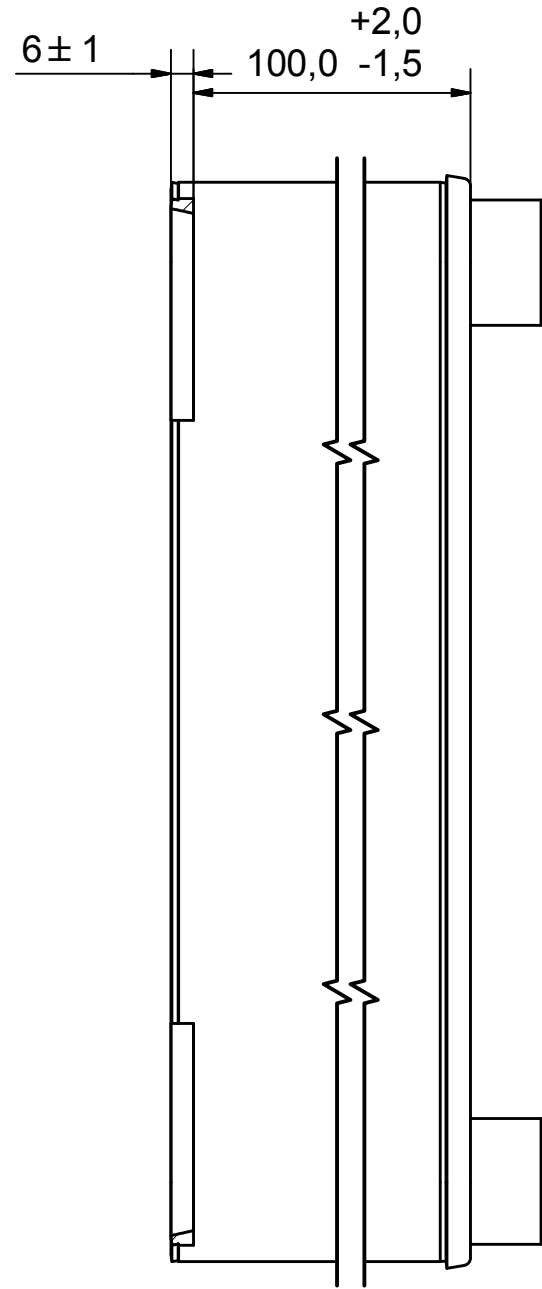
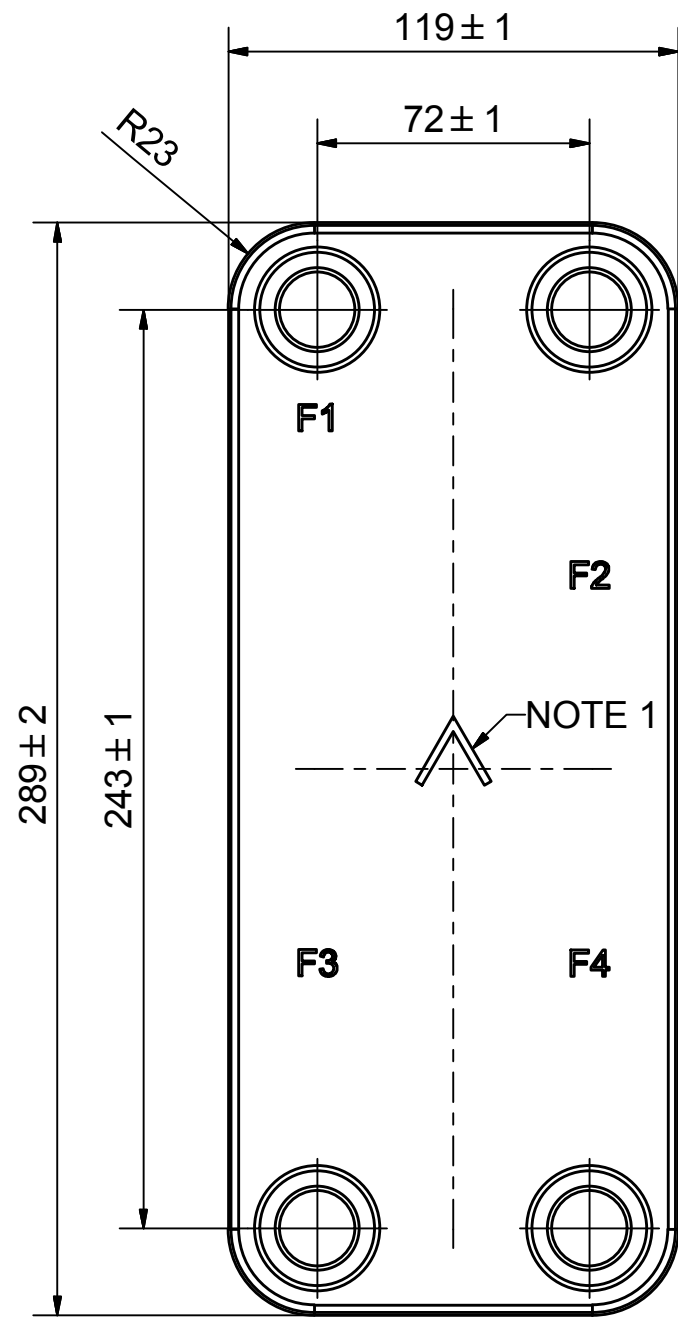

AXINTRA

ÉCHANGEURS THERMIQUES

F4	32566	ISO-G 1" A & SOLDER 22U, TH = 20,1	CD000806
F3	32566	ISO-G 1" A & SOLDER 22U, TH = 20,1	CD000806
F2	32566	ISO-G 1" A & SOLDER 22U, TH = 20,1	CD000806
F1	32566	ISO-G 1" A & SOLDER 22U, TH = 20,1	CD000806

Pos	Article No	Title / Denomination, code, material, dimension etc	Drawing No./ref	Pos	Article No	Title / Denomination, code, material, dimension etc	Drawing No./ref
-----	------------	---	-----------------	-----	------------	---	-----------------

NOTE 1 ALTERNATE MARKING: STICKER OR STAMP

Title		B10TSH/1P-SPS-S	
 A DOVER COMPANY		Created Date	Created By
		2018-08-21	AU
Article/Configuration number		Drawing number	
17314-040		AU00400900	

Rev No.	Alteration	Date	Checked	Approved
1	CHANGED DENOMIATION	2007/05/28	ANL	PDM

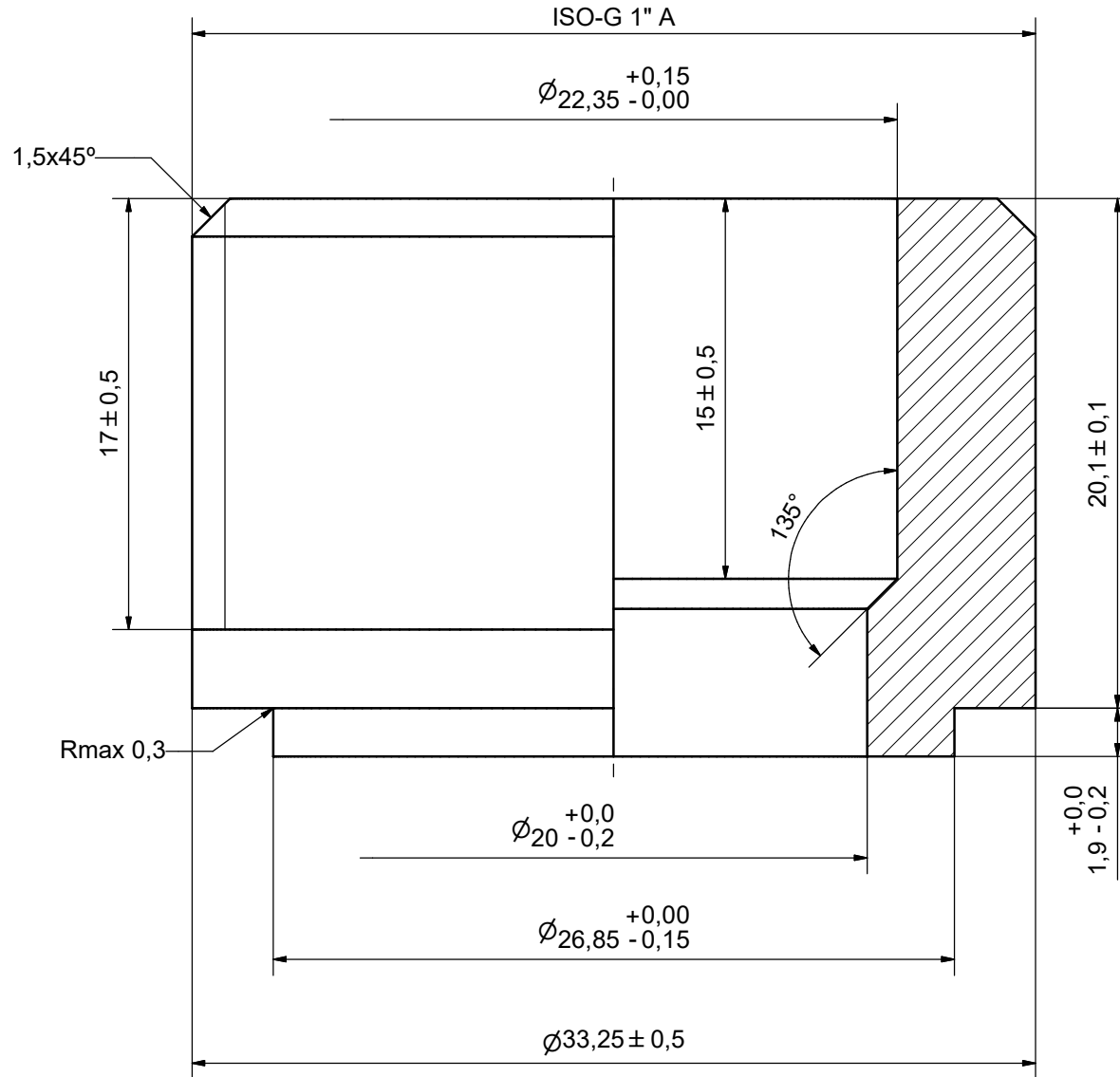
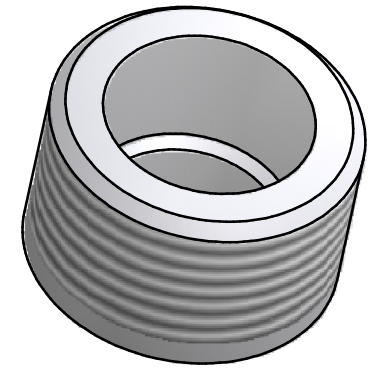

ACCORDING TO MQS
MATERIAL

Drawn	Checked	Approved	Created Date	General geometrical tolerancing ISO 2768	General surface finish R_a	Scale
THE	PDM	PDM	2006/05/09	m	3.2	5:1
Title			ISO-G 1" A & SOLDER 22U			
Article number		Drawing number		Revision	Sheet	
-		CD000806		1	1 (1)	

© Company Confidential, Property of SWEP International AB

AXINTRA
ÉCHANGEURS THERMIQUES

SWEP
A DOVER COMPANY