

B120T

Le B120T a été spécialement conçu pour fonctionner dans des applications de chauffage et industrielles exigeantes, généralement des applications eau-eau et des refroidisseurs d'huile. Ce produit a contribué à l'échange rapide des échangeurs de chaleur traditionnels à plaques et joint, ou à calandre en faveur des BPHE. Il est largement utilisé comme condenseur dans des applications de climatisation et de réfrigération.



Spécifications de base

Nombre de plaques max. (NoP)	250
Débit volumétrique max.	27,4 m³/h (17.61 gpm)
Volume du canal	0.241/0.241 dm³ (0.0085/0.0085 ft³)
Matières	Plaques en acier inoxydable 316, brasage cuivre
Poids sans les connexions	8.33+(0.404*NoP) kg 18.36+(0.891*NoP) lb

Les dimensions standard

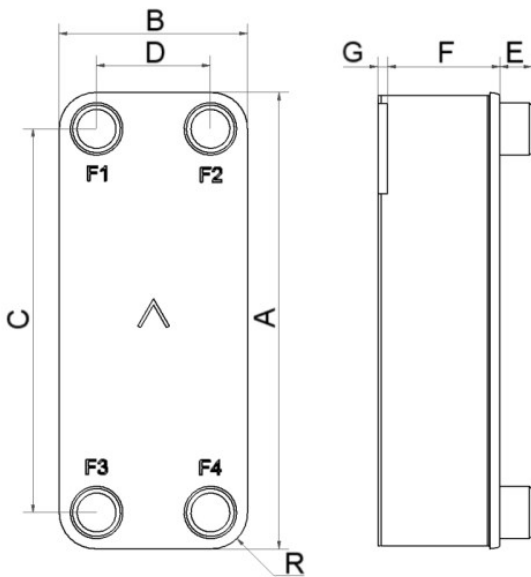

#	MM	IN
A	525	20.67
B	243	9.57
C	456	17.95
D	174	6.85
F	10.00+2.29*(NoP)	0.39+0.09*(NoP)
G	4	0.16
R	35	1.38
E_1	27	1.06

PED pression / température

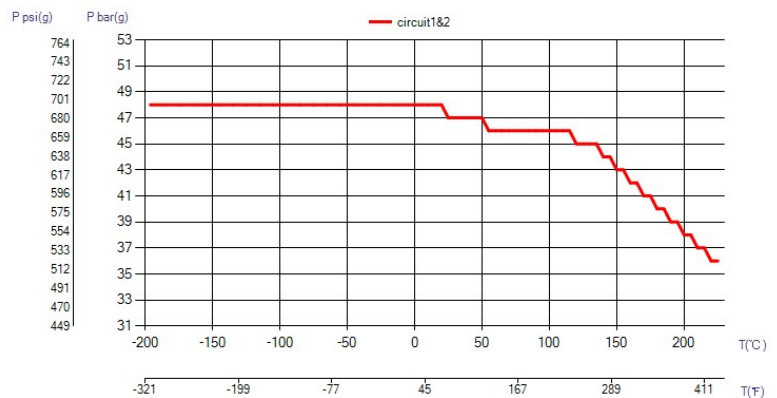

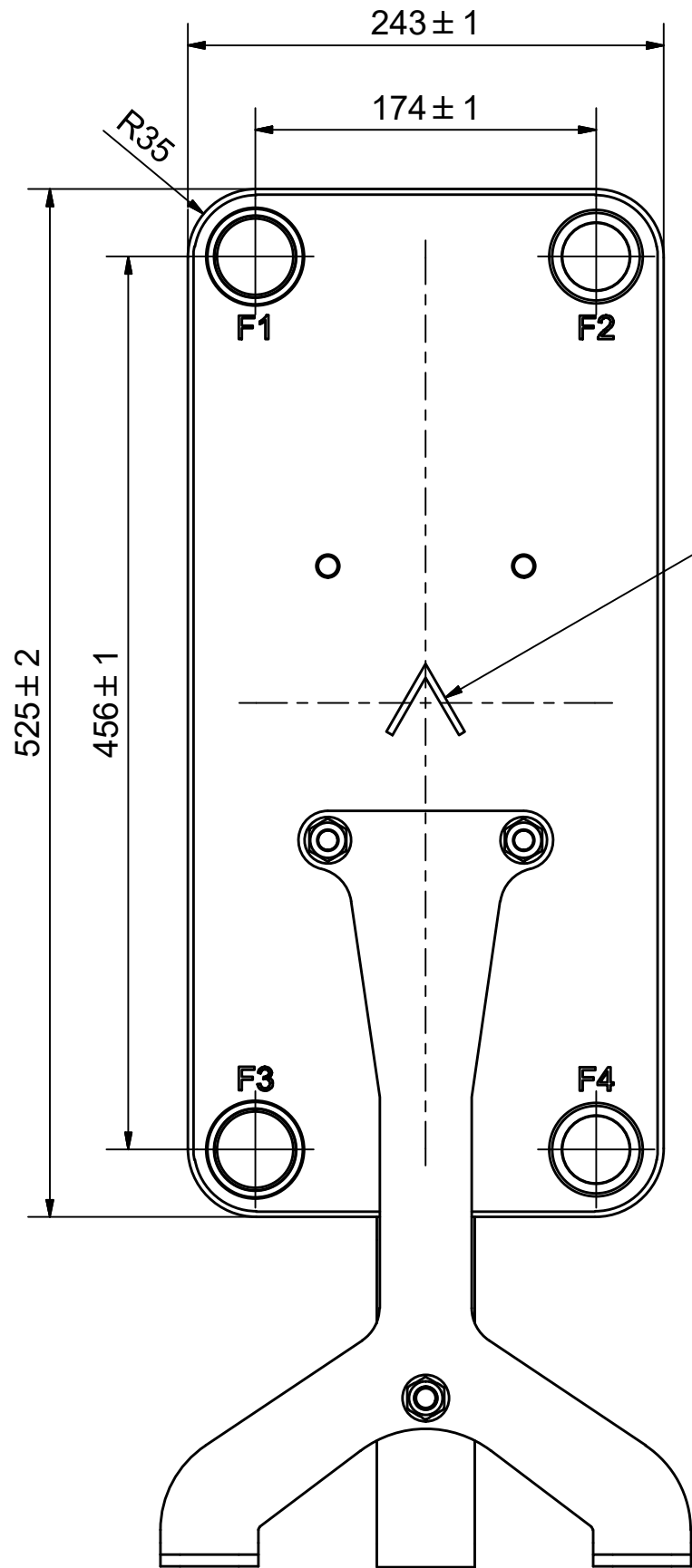

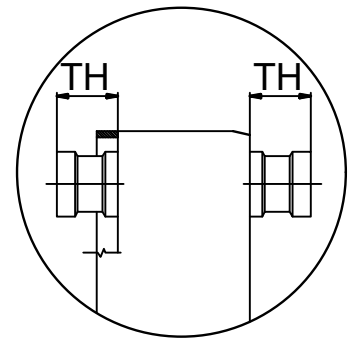
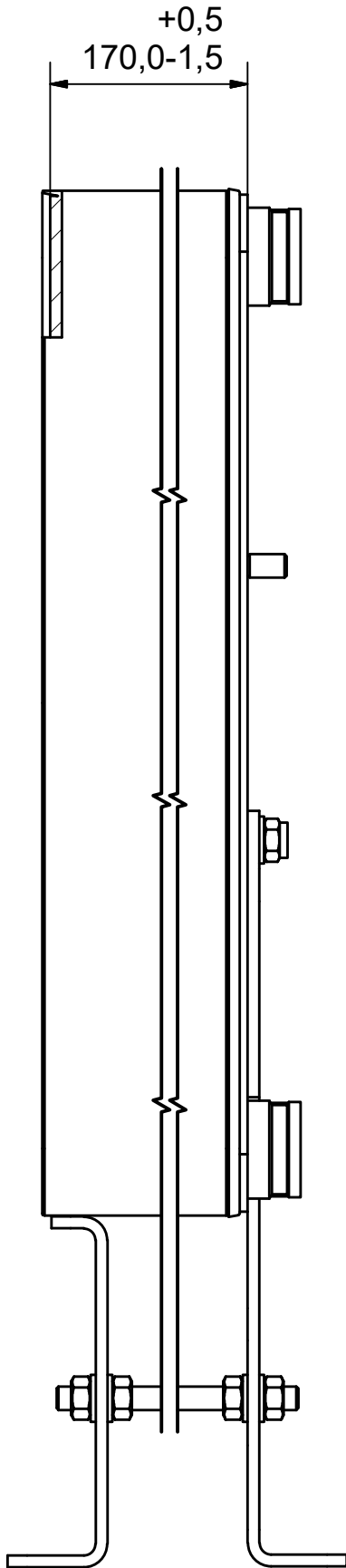

NOTE 1



NOTE 1 ALTERNATE MARKING: STICKER OR STAMP

F4	32836	ISO-G 1 1/2" & SOLDER 35,1, TH =	CD000860
F3	45083	SOLDER 42U, TH = 27.1	CD000100
F2	32836	ISO-G 1 1/2" & SOLDER 35,1, TH =	CD000860
F1	45083	SOLDER 42U, TH = 27.1	CD000100
F	28020	B120T/50/57 SUPPORT LEG	CG450025_2
F	21118	B120T/50 BOLT LOC F 4x C140x100	CG450024_1

Pos	Article No	Title / Denomination, code, material, dimension etc	Drawing No./ref	Pos	Article No	Title / Denomination, code, material, dimension etc	Drawing No./ref
-----	------------	-----------------------------------------------------	-----------------	-----	------------	-----------------------------------------------------	-----------------

Title		B120TH/1P-SC-M	
 A DOVER COMPANY	Created Date	Created By	
	12/6/2021	AU	
Article/Configuration number		Drawing number	
14171-070		AU00673713_14171-070	

Rev No	Alteration	Date	Checked	Approved
06	Added NOTE 4 and size 220 to NOTE 1.	2019-05-17	SKDS	PDM

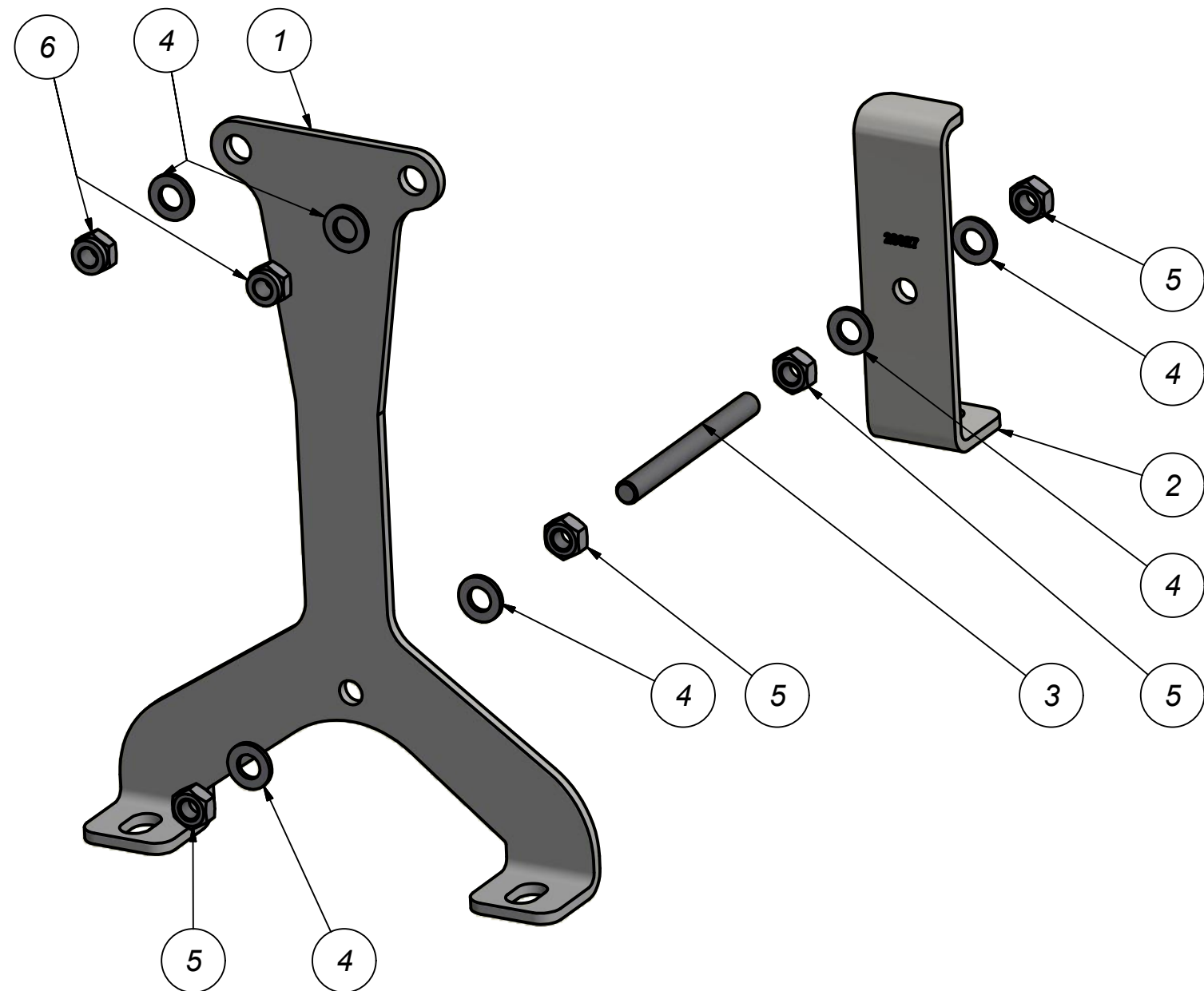
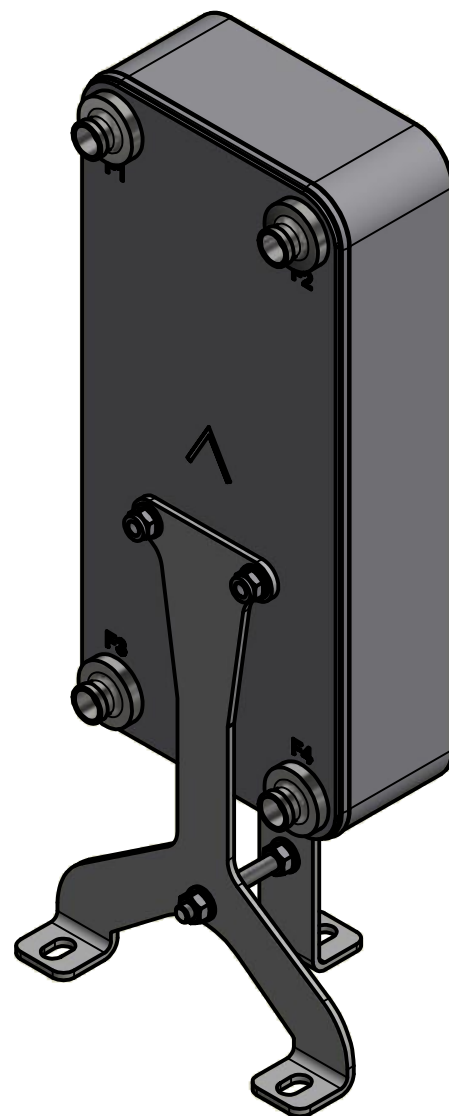
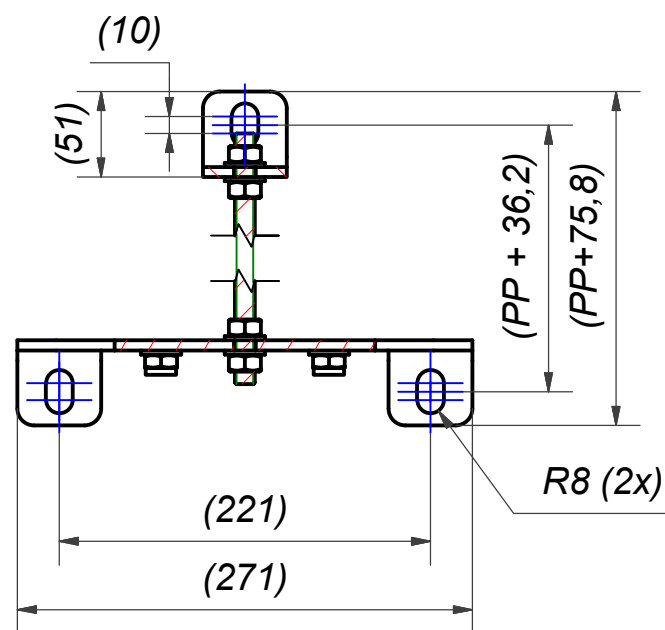
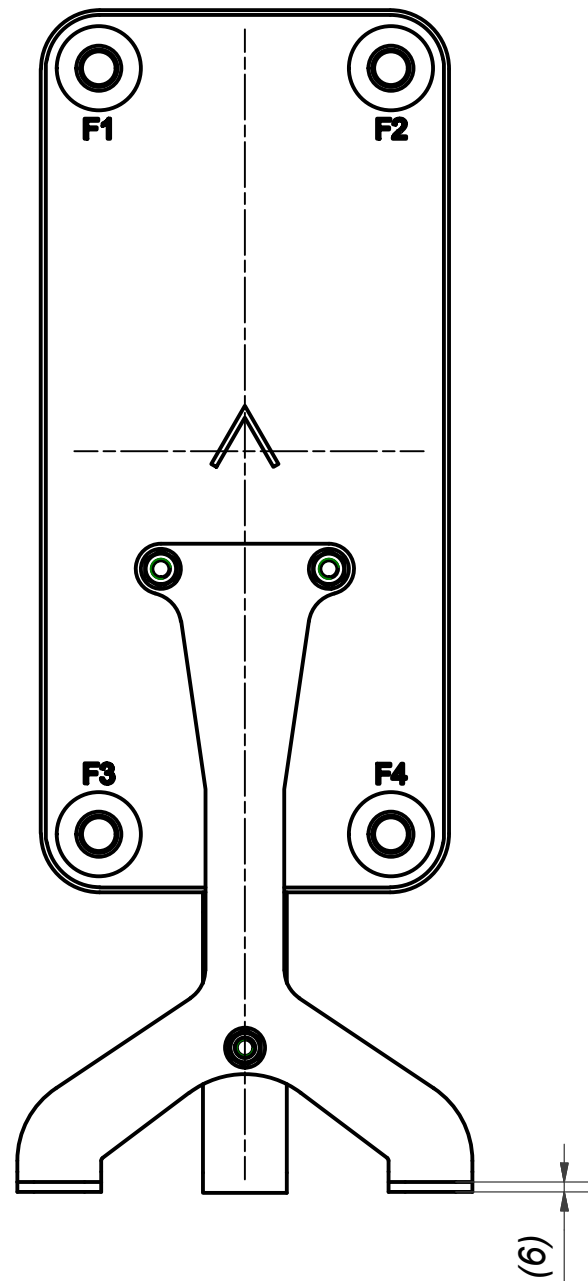

NOTE 4: For size 220 is required for connections to have diameter of MAX 65 mm.
NOTE 3: Length of threaded bar according drawing CC000168.
NOTE 2: For B57 with STD Conn. Stud bolt 21235 is required.
NOTE 1: Requires stud bolt 21118, 21120, 24023 (B45, 50, 56, 120T, 200, 220, 320LT, 320HT)

ITEM	QTY	TITLE	Drawing No.
6	2	DIN 985 - M12	DIN 985 - M12
5	4	NUT M12 M6M 8M FZB, 45889	DIN 934 - M12
4	6	WASHER ART. NO 45524	13x24x2.5
3	1	THREADED BAR M12	CC000168
2	1	B35/45/50/57 SUPPORT LEG. ART.NO.28027	CC000165
1	1	B45/50/57 SUPPORT LEG, ART.NO. 28029	CC000167

Drawn	Checked	Approved	Created Date	General geometrical tolerancing ISO 2768:	General surface finish R_a :	Scale	Paper size
lathe	PDM	PDM	2005-07-27			-	A3

SWEP
A DOVER COMPANY

B120/50/57 SUPPORT LEG

Article / Tool number	Design Type	Drawing number	Revision	Sheet
CG	CG	CG450025	06	1 (1)

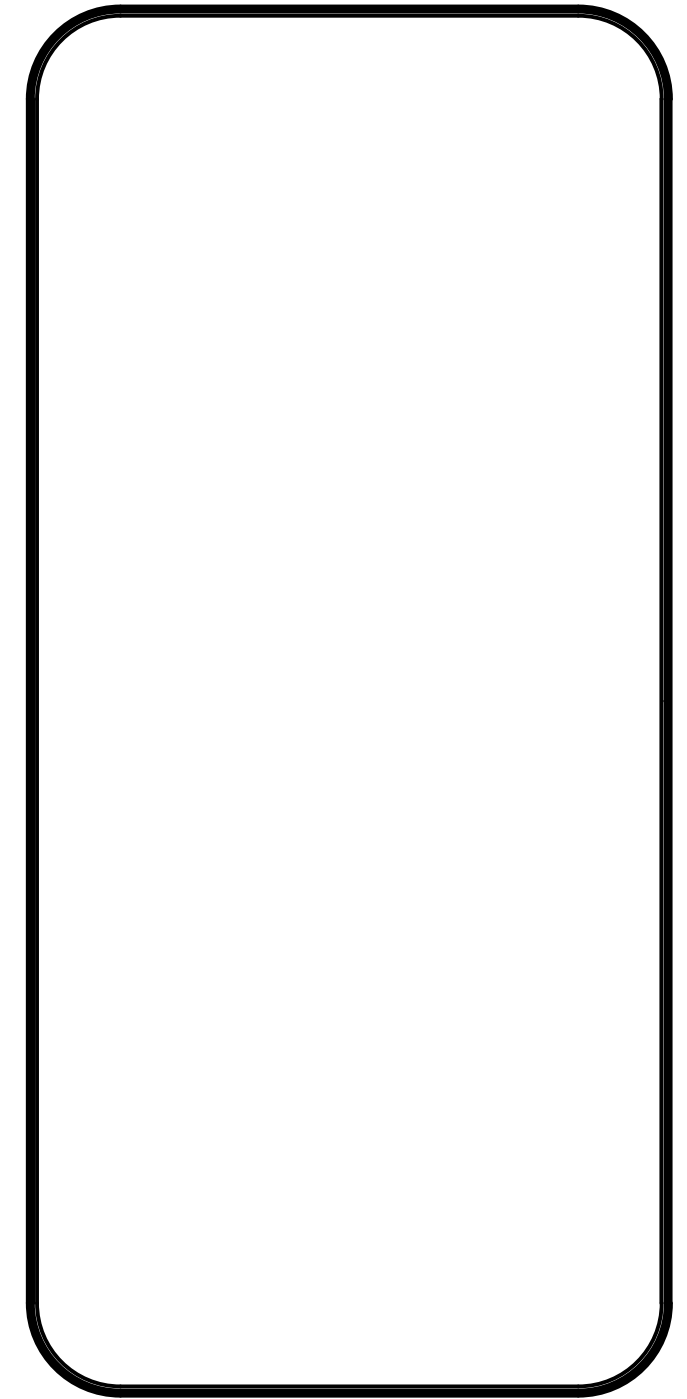
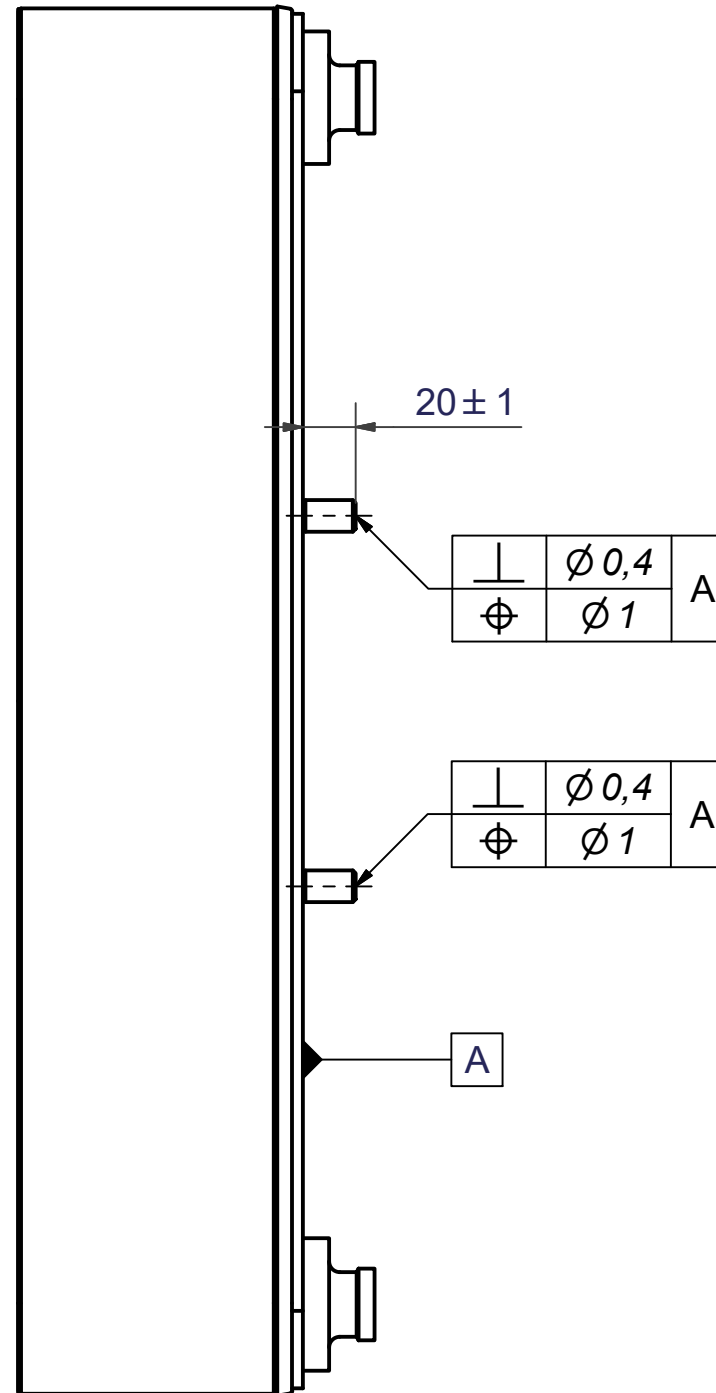
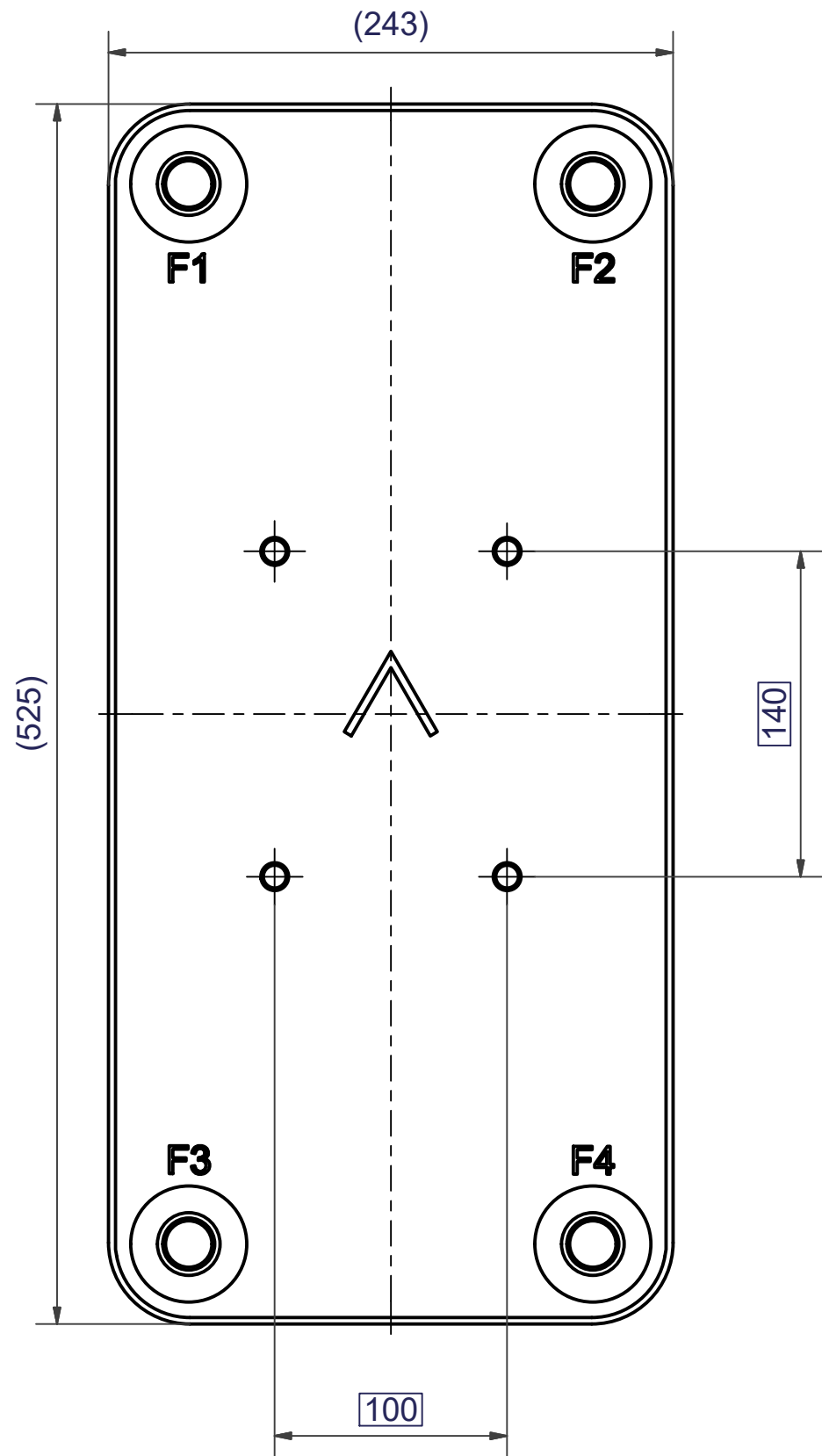

1	4	STUD BOLT M12x20 ART. NO. 45095	M12x20
IT	QTY	DESCRIPTION	Drawing No./Ref
lathe	PDM	PDM	2004-10-12
		General geometrical tolerancing ISO 2768: m	General surface finish R _a : 3.2
		1:1	
		B120T/50 BOLT LOC F 4x C140x100	
Article number 21118		Drawing number CG450024	
		Revision 00	
		Sheet 1 (1)	

Rev No.	Alteration	Date	Checked	Approved
12	DEBURRING INFO ADDED	2009/03/10	TL	PDM

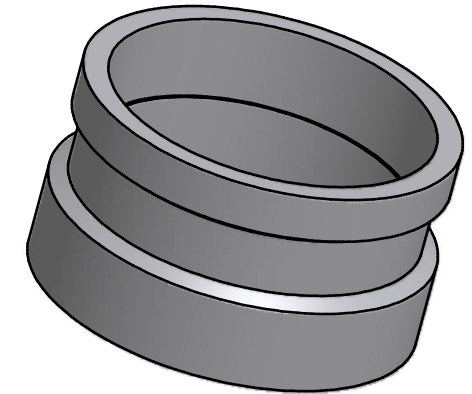
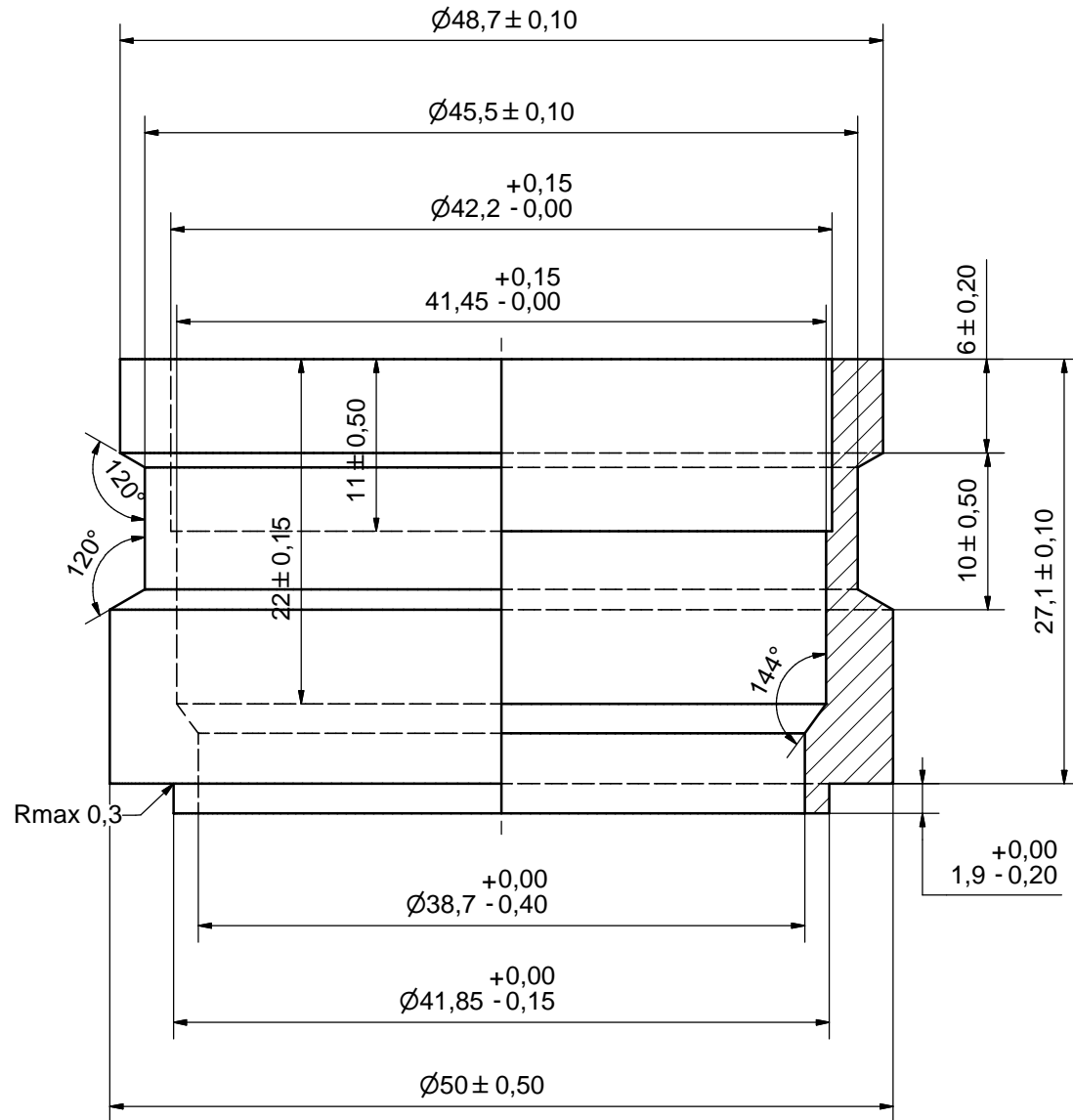

SHARP EDGES DEBURRED MAX 0,4

ACCORDING TO MQS
MATERIAL

Drawn SA	Checked TP	Approved VP	Created Date 1990-09-08	General geometrical tolerancing ISO 2768 m	General surface finish R_a 3.2	Scale -
Title SOLDER 42U			Article number -	Drawing number CD000100	Revision 12	Sheet 1 (1)

Rev No.	Alteration	Date	Checked	Approved
1	DEBURRING INFO ADDED	2009/03/11	TL	PDM

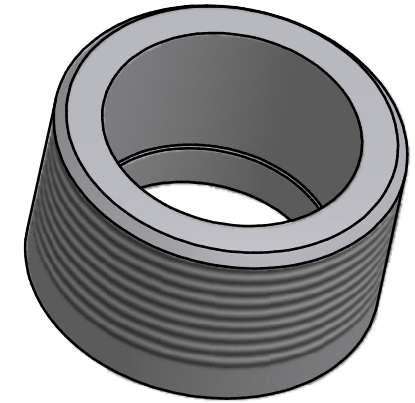
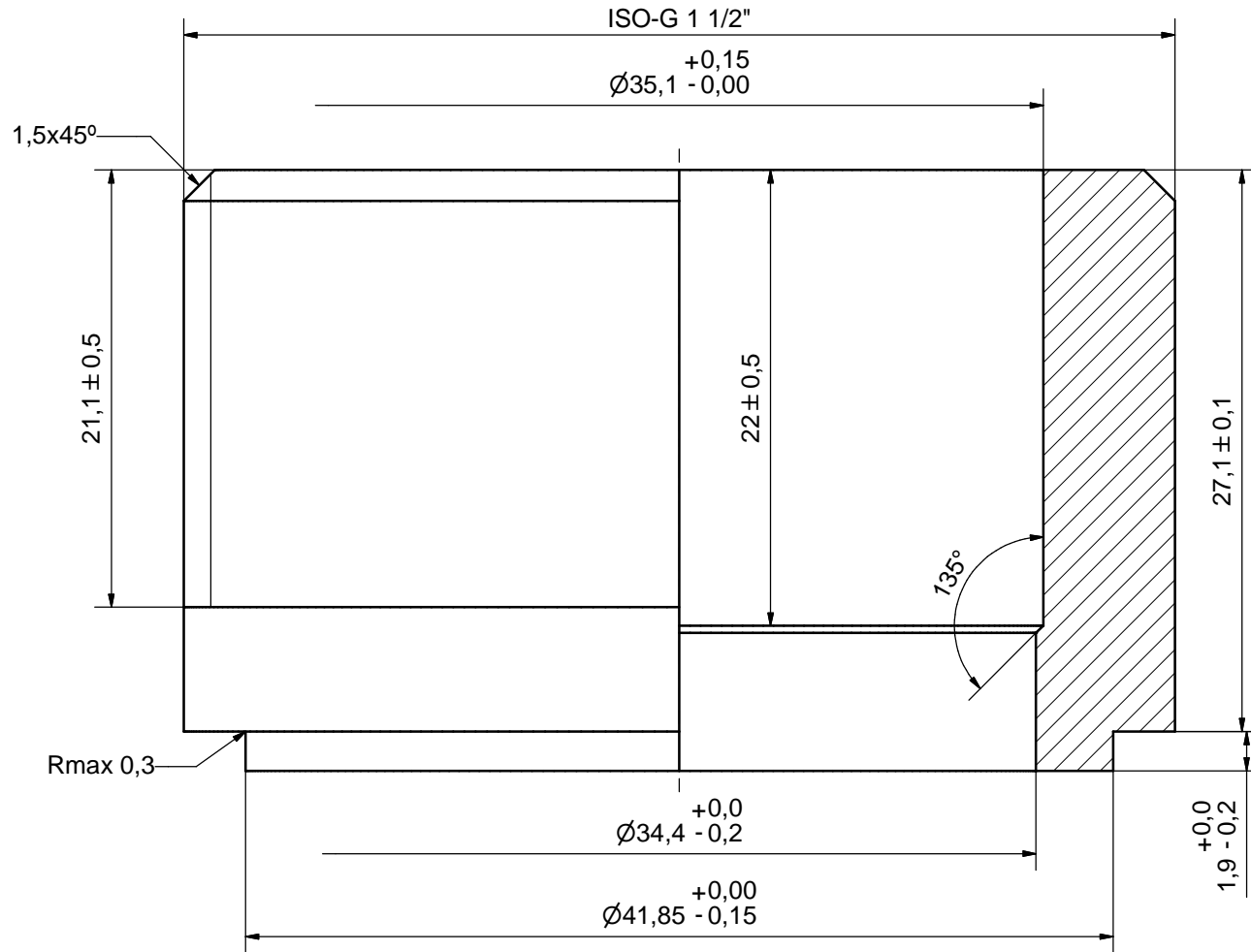

SHARP EDGES DEBURRED MAX 0,4

ACCORDING TO MQS
MATERIAL

Drawn ANL	Checked PDM	Approved PDM	Created Date 2007-04-25	General geometrical tolerancing ISO 2768 m	General surface finish R_a 3.2		Scale -
			Title ISO-G 1 1/2" & SOLDER 35,1				
Article number -		Drawing number CD000860		Revision 1		Sheet 1 (1)	