

# B15T

Très performant, le B15T a été développé pour offrir une efficacité thermique maximale. La précision de nos échangeurs autorise un fonctionnement efficace même avec des pincements extrêmement faibles. Ce produit est donc un choix évident pour les applications exigeant un flux thermique élevé, ainsi que pour un meilleur rendement énergétique.



## Spécifications de base

Nombre de plaques max. (NoP)	60
Débit volumétrique max.	4 m <sup>3</sup> /h (17.61 gpm)
Volume du canal	0.063/0.063 dm <sup>3</sup> (0.0022/0.0022 ft <sup>3</sup> )
Matières	Plaques en acier inoxydable 316, brasage cuivre
Poids sans les connexions	1.25+(0.104*NoP) kg 2.76+(0.229*NoP) lb

## Les dimensions standard

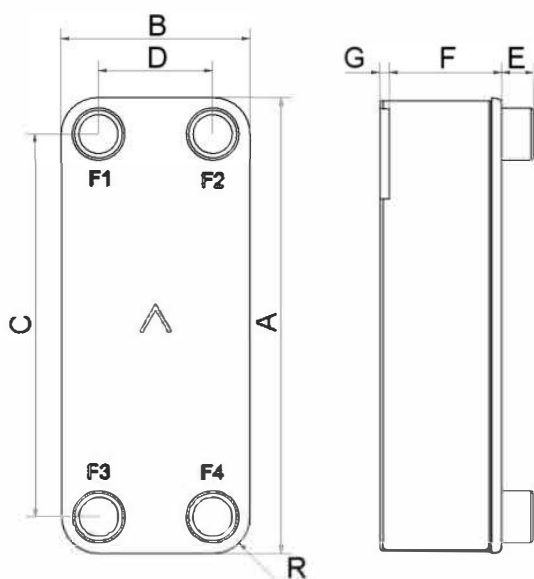

#	MM	IN
A	468	18.43
B	76	2.99
C	432	17.01
D	40	1.57
F	4.00+2.24*(NoP)	0.16+0.09*(NoP)
G	7	0.28
R	18	0.71
E_1	20	0.79

## PED pression / température

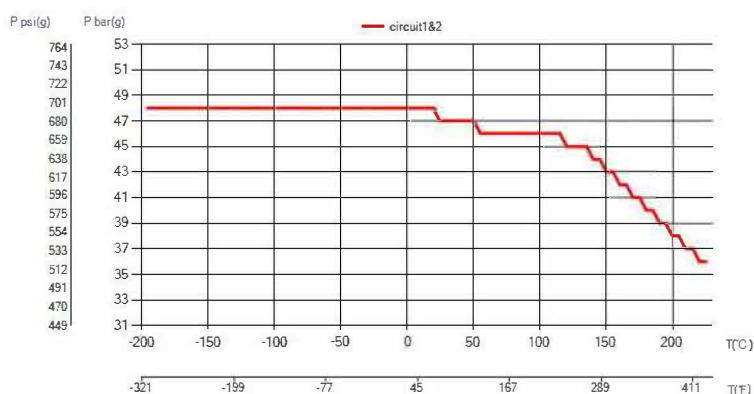

# AXINTRA

ÉCHANGEURS THERMIQUES

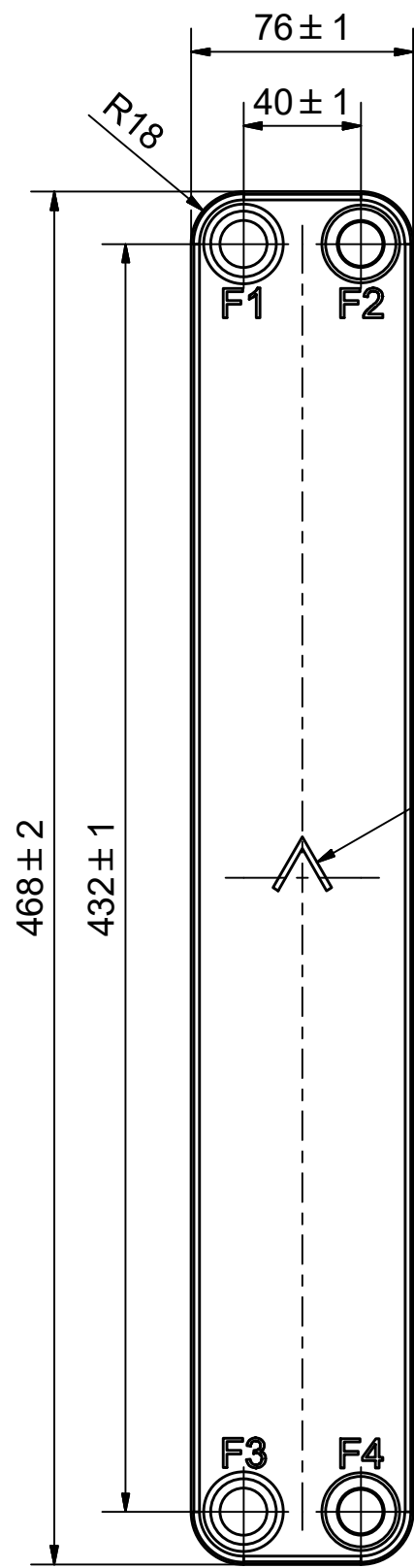

NOTE 1

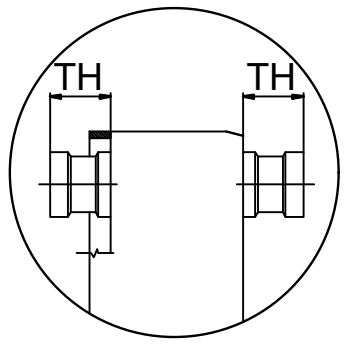
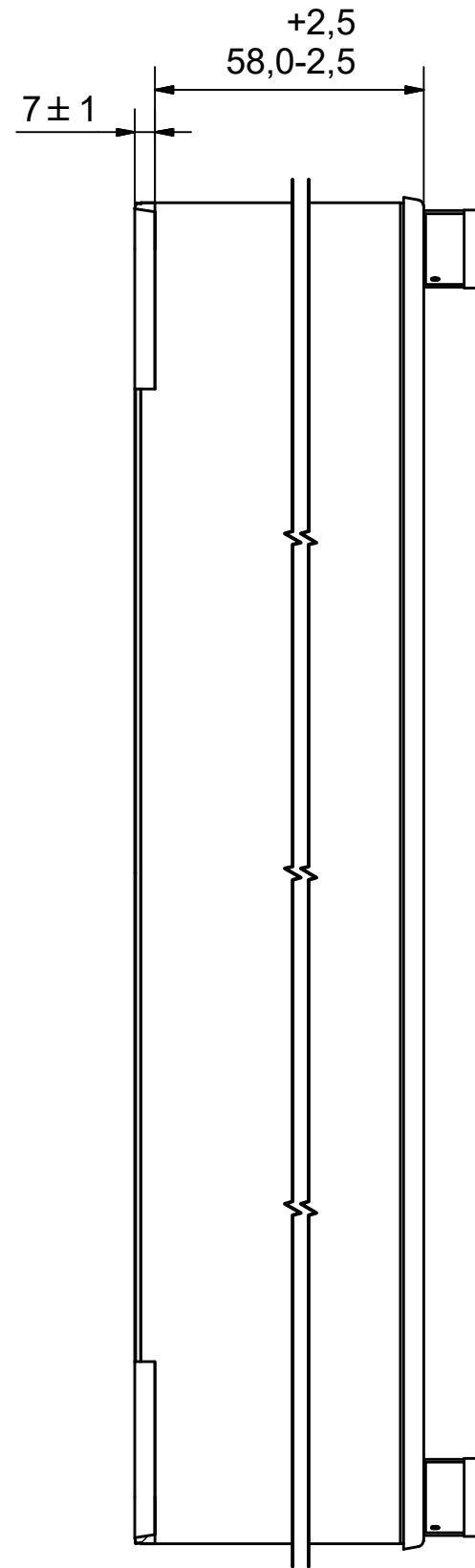

**AXINTRA**

ÉCHANGEURS THERMIQUES

F4	32835	ISO-G 3/4" & SOLDER 16, TH = 20,1	CD000859
F3	33221	SOLDER 22U, TH = 20,1	CD001017
F2	32835	ISO-G 3/4" & SOLDER 16, TH = 20,1	CD000859
F1	33221	SOLDER 22U, TH = 20,1	CD001017

NOTE 1 ALTERNATE MARKING: STICKER OR STAMP

Pos	Article No	Title / Denomination, code, material, dimension etc	Drawing No./ref	Pos	Article No	Title / Denomination, code, material, dimension etc	Drawing No./ref
-----	------------	---	-----------------	-----	------------	---	-----------------

Title		<b>B15TH/1P-SC-M</b>	
		Created Date	2019-01-22
		Created By	AU
		Article/Configuration number	15864-024
		Drawing number	AU00453397

REV	ALTERATION	DATE	CHECKED	APPROVED
02	DESIGN CHANGE ACCORDING TO DOC RD101273	2015/12/14	CNVG	PDM

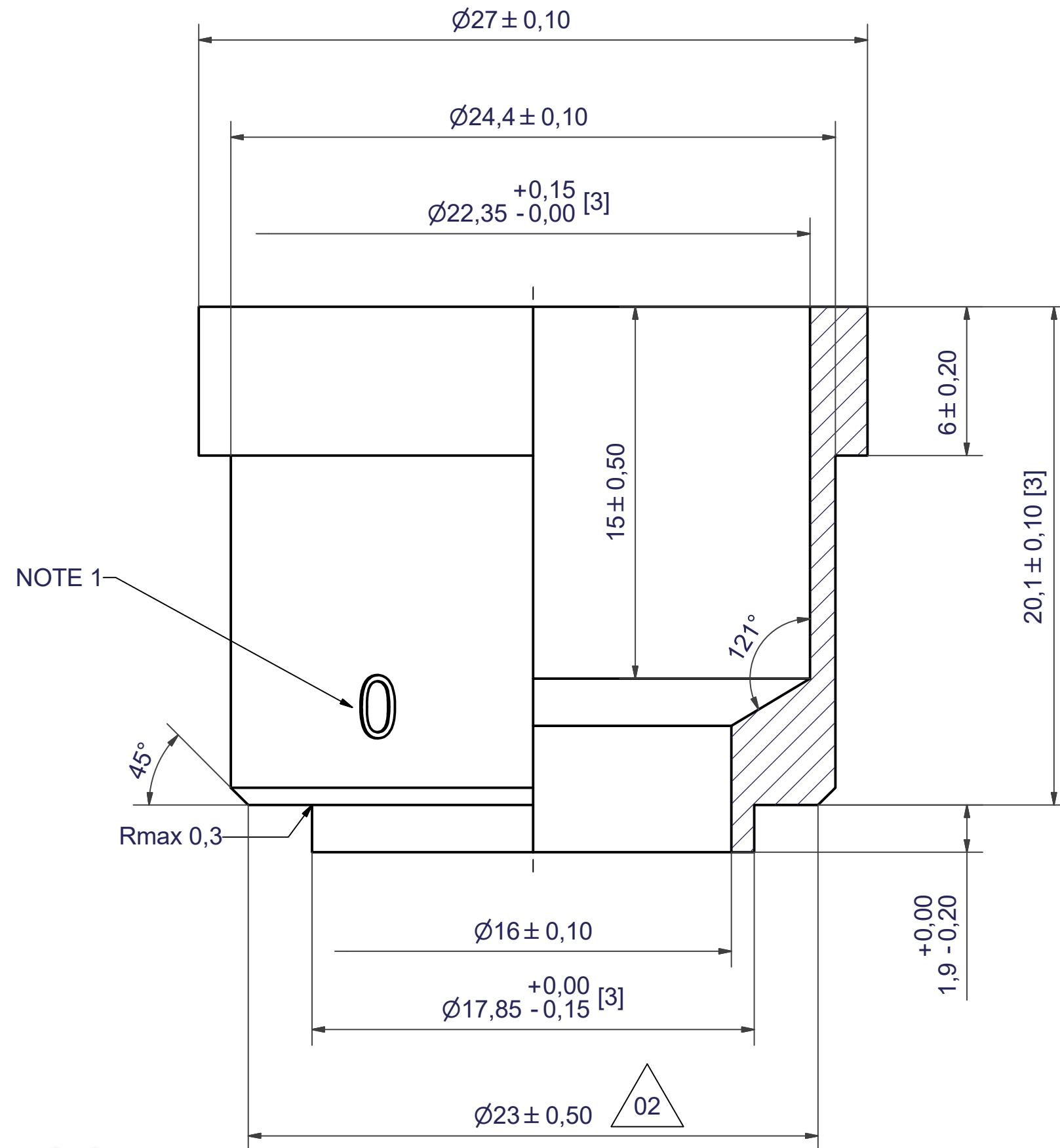
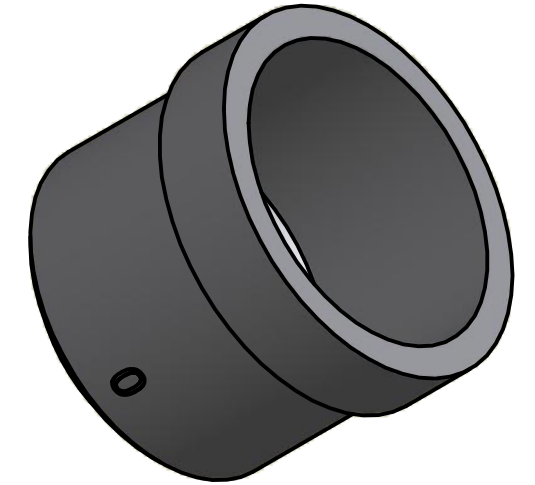

NOTE 2: [3] - CRITICAL/SPECIAL CHARACTERISTIC TO BE FOLLOWED  
NOTE 1: MARKING TEXT "0" FOR IDENTIFICATION ONLY  
PRESENT AT 2 PLACES  $180^\circ$  FROM EACH OTHER  
0 = 304 MATERIAL

ACCORDING TO MQS  
MATERIAL

Drawn <i>inrj</i>	Checked <i>PDM</i>	Approved <i>PDM</i>	Created Date 2008-06-27	General geometrical tolerancing ISO 2768 <i>m</i>	General surface finish $R_a$ 3.2	Scale -
			Title <b>SOLDER 22U</b>			
Article number		Drawing number <b>CD001017</b>		Revision 02		Sheet 1 (1)

Rev No.	Alteration	Date	Checked	Approved
1	CHANGED INNER DIAMETER	2007/09/17	ANL	PDM

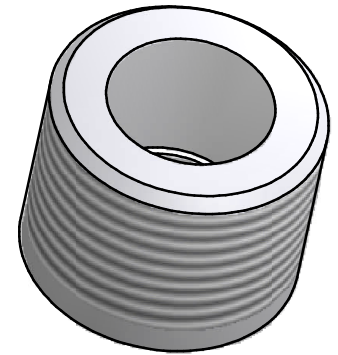
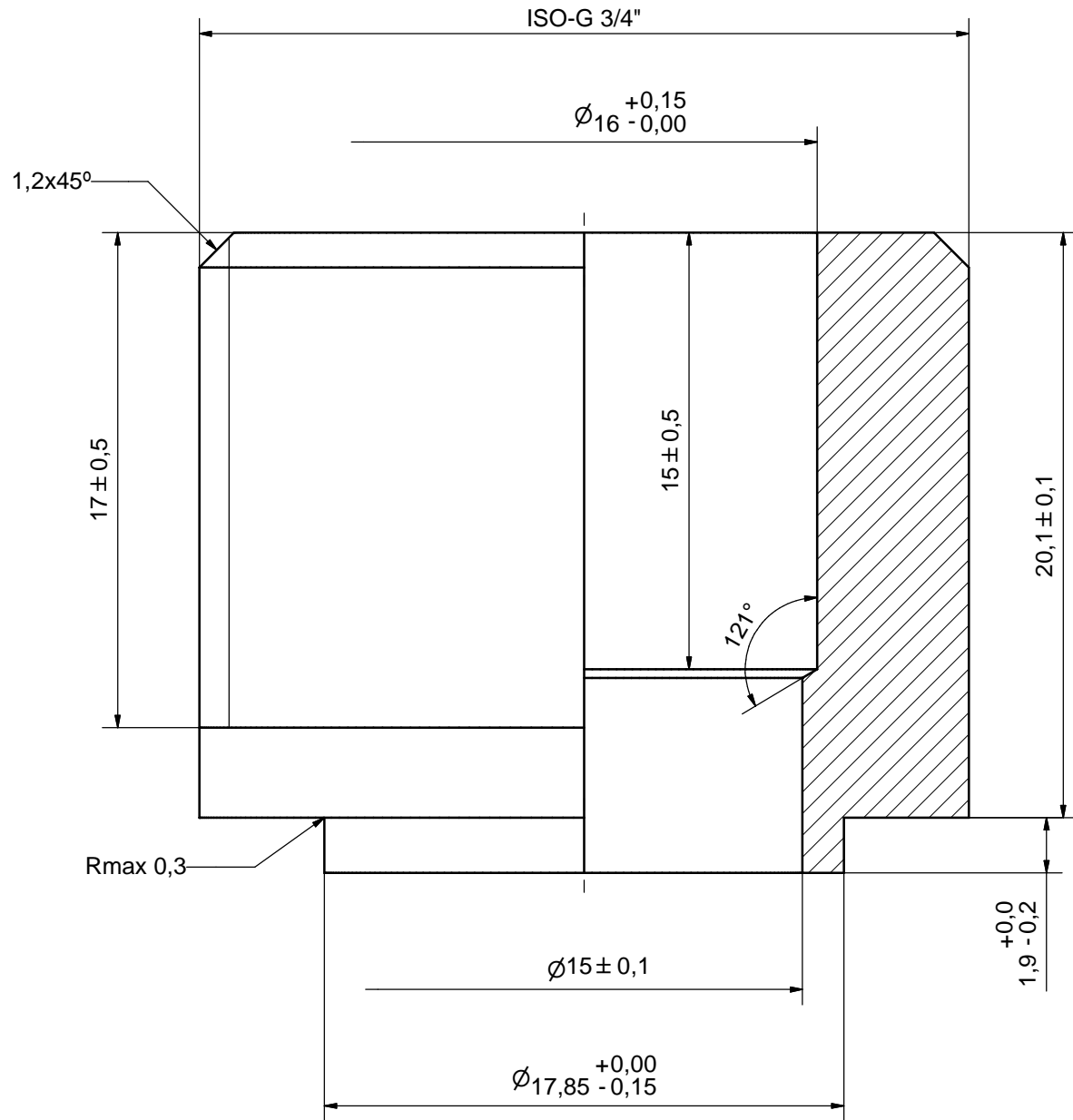

ACCORDING TO MQS  
MATERIAL

Drawn	Checked	Approved	Created Date	General geometrical tolerancing ISO 2768	General surface finish $R_a$	Scale
ANL	PDM	PDM	2007/04/25	m	3.2	5:1
<b>SUPER</b> A DOVER COMPANY						
Title			ISO-G 3/4" & SOLDER 16			
Article number		Drawing number		Revision	Sheet	
-		CD000859		1	1 (1)	

© Company Confidential, Property of SWEP International AB

**AXINTRA**  
ÉCHANGEURS THERMIQUES