

# B25T

Le modèle B25T propose des solutions d'échange thermique efficace pour une large fourchette de capacités. La polyvalence et l'excellent transfert thermique de ce produit en font le choix idéal pour les applications eau/eau exigeantes et comme de très performance condenseurs.



## Spécifications de base

Nombre de plaques max. (NoP)	140
Débit volumétrique max.	9 m <sup>3</sup> /h (39.63 gpm)
Volume du canal	0.111/0.111 dm <sup>3</sup> (0.0039/0.0039 ft <sup>3</sup> )
Matières	Plaques en acier inoxydable 316, brasage cuivre
Poids sans les connexions	2.13+(0.1775*NoP) kg 4.69+(0.391*NoP) lb

## Les dimensions standard

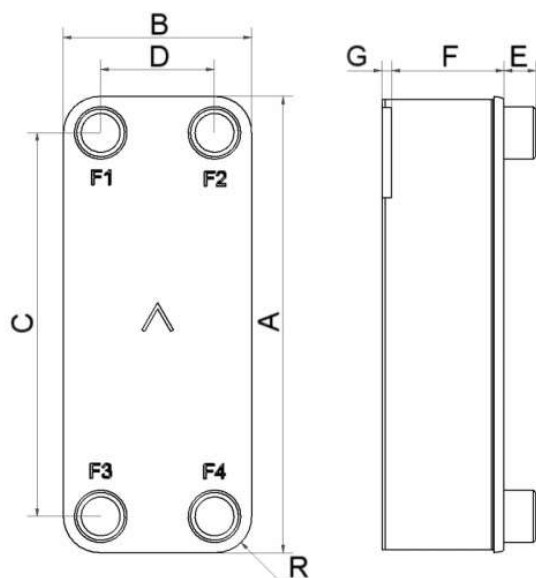

#	MM	N
A	526	20.71
B	119	4.69
C	479	18.86
D	72	2.83
F	4.00+2.25*(NoP)	0.16+0.09*(NoP)
G	6	0.24
R	23	0.91
E_1	20	0.79

## PED pression / température

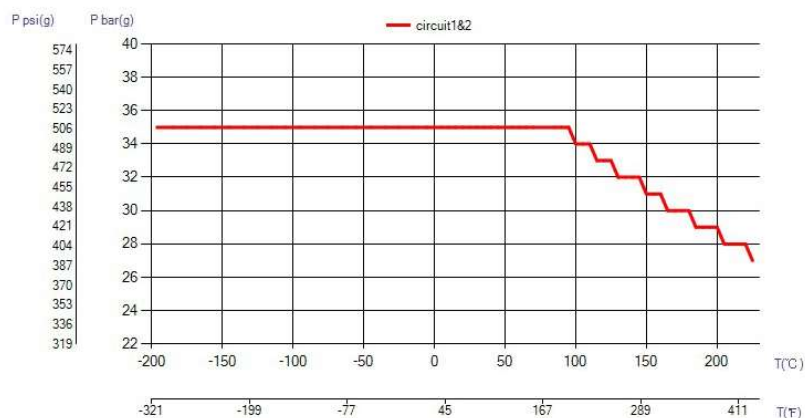

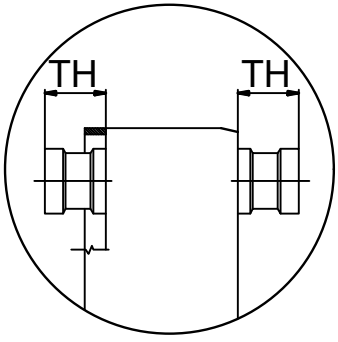
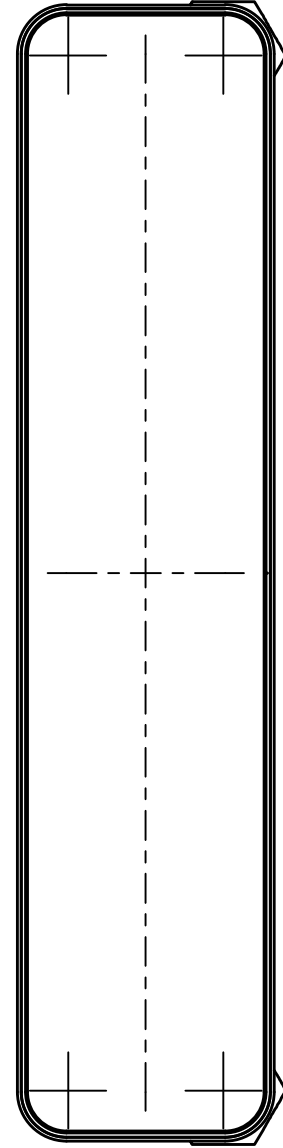
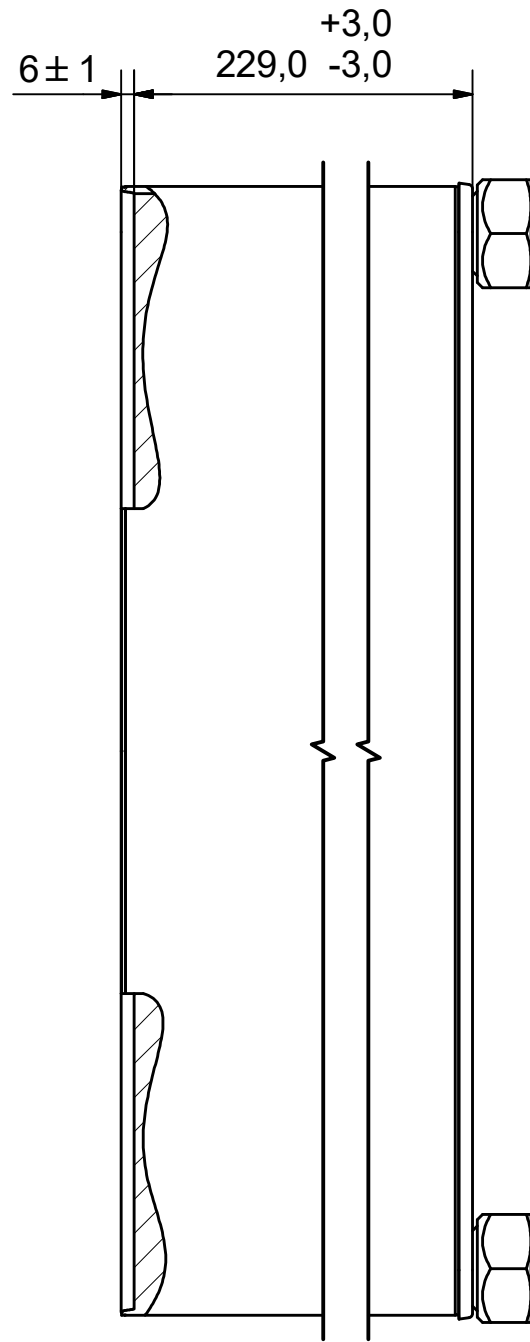
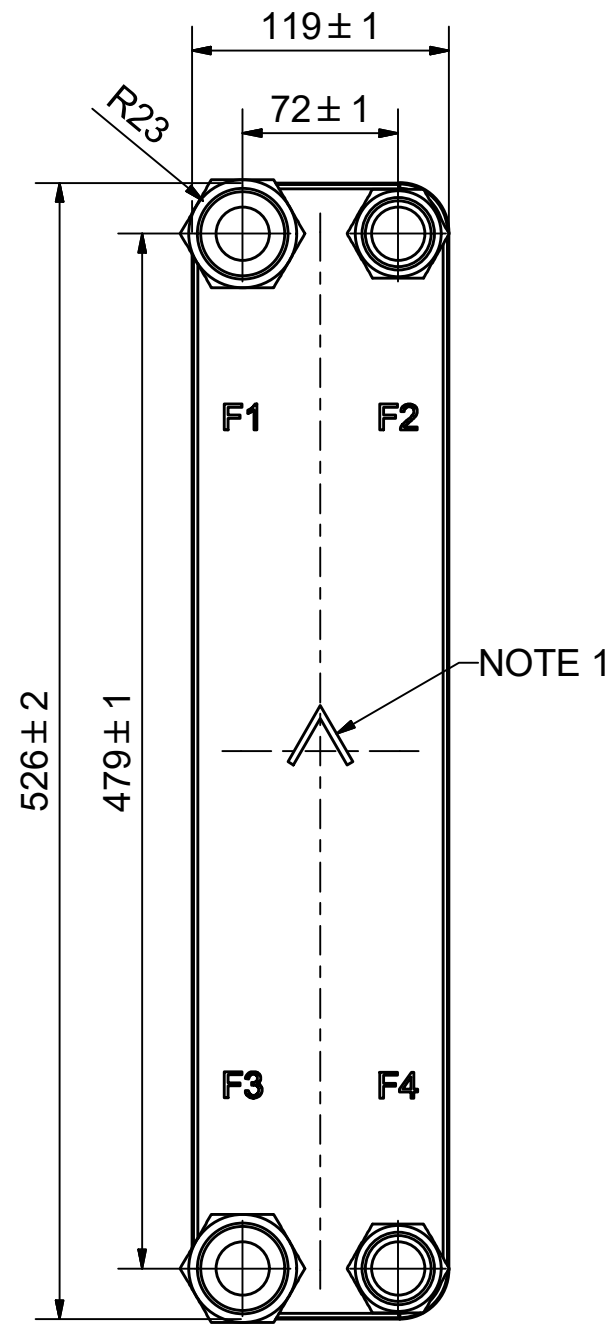



**AXINTRA**  
ÉCHANGEURS THERMIQUES

NOTE 1 ALTERNATE MARKING: STICKER OR STAMP

B25T PWO OKR1105

F4	45397	ISO-G 1 INT. HEX., TH = 27,1	CD000001
F3	45428	ISO-G 1 1/4 (INT- HEX), TH = 27,1	CD000002
F2	45397	ISO-G 1 INT. HEX., TH = 27,1	CD000001
F1	45428	ISO-G 1 1/4 (INT- HEX), TH = 27,1	CD000002

Title		B25TH/1P-SC-S	
 A DOVER COMPANY	Created Date	Created By	
	2018-02-22	AU	
	Article/Configuration number	Drawing number	
	13847-100	AU00352277	

Pos	Article No	Title / Denomination, code, material, dimension etc	Drawing No./ref	Pos	Article No	Title / Denomination, code, material, dimension etc	Drawing No./ref
-----	------------	---	-----------------	-----	------------	---	-----------------

Rev No	Alteration	Date	Checked	Approved
14	DIMENSION CORRECTED	2014-06-02	SKMTB	VP

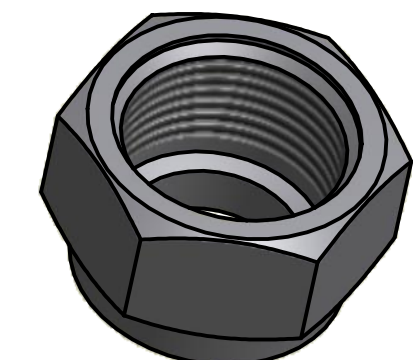
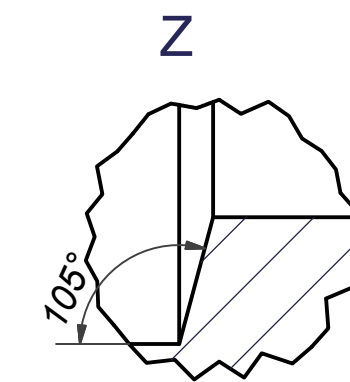
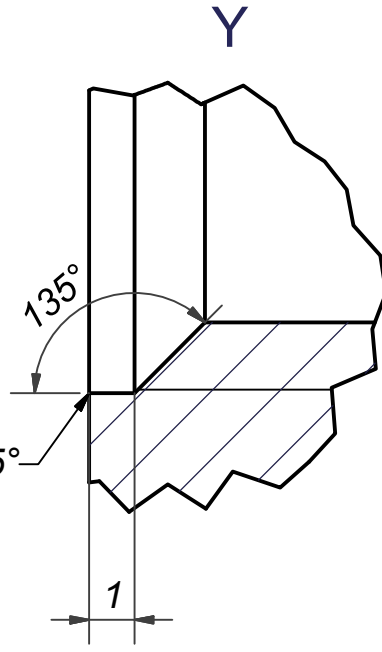
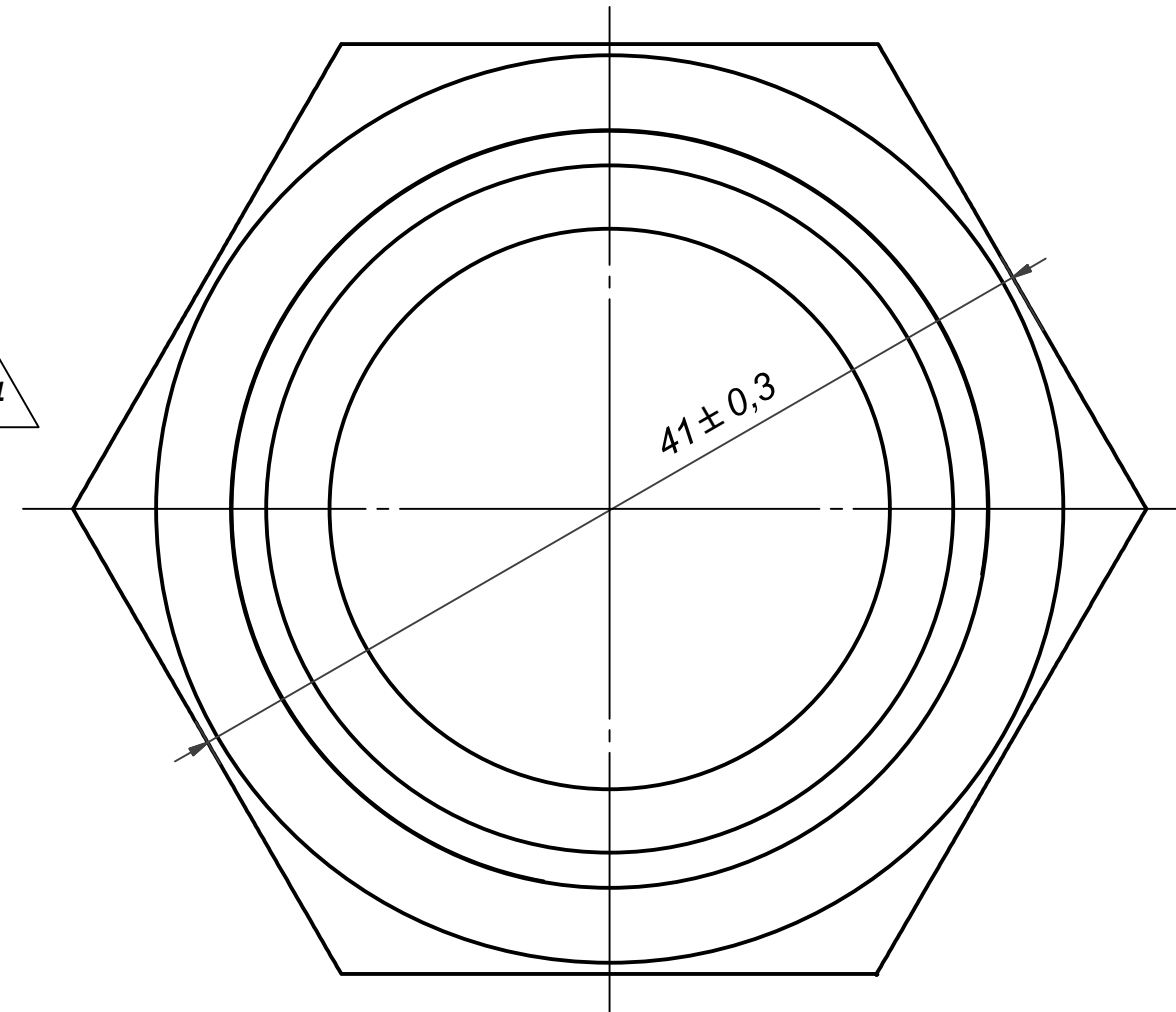
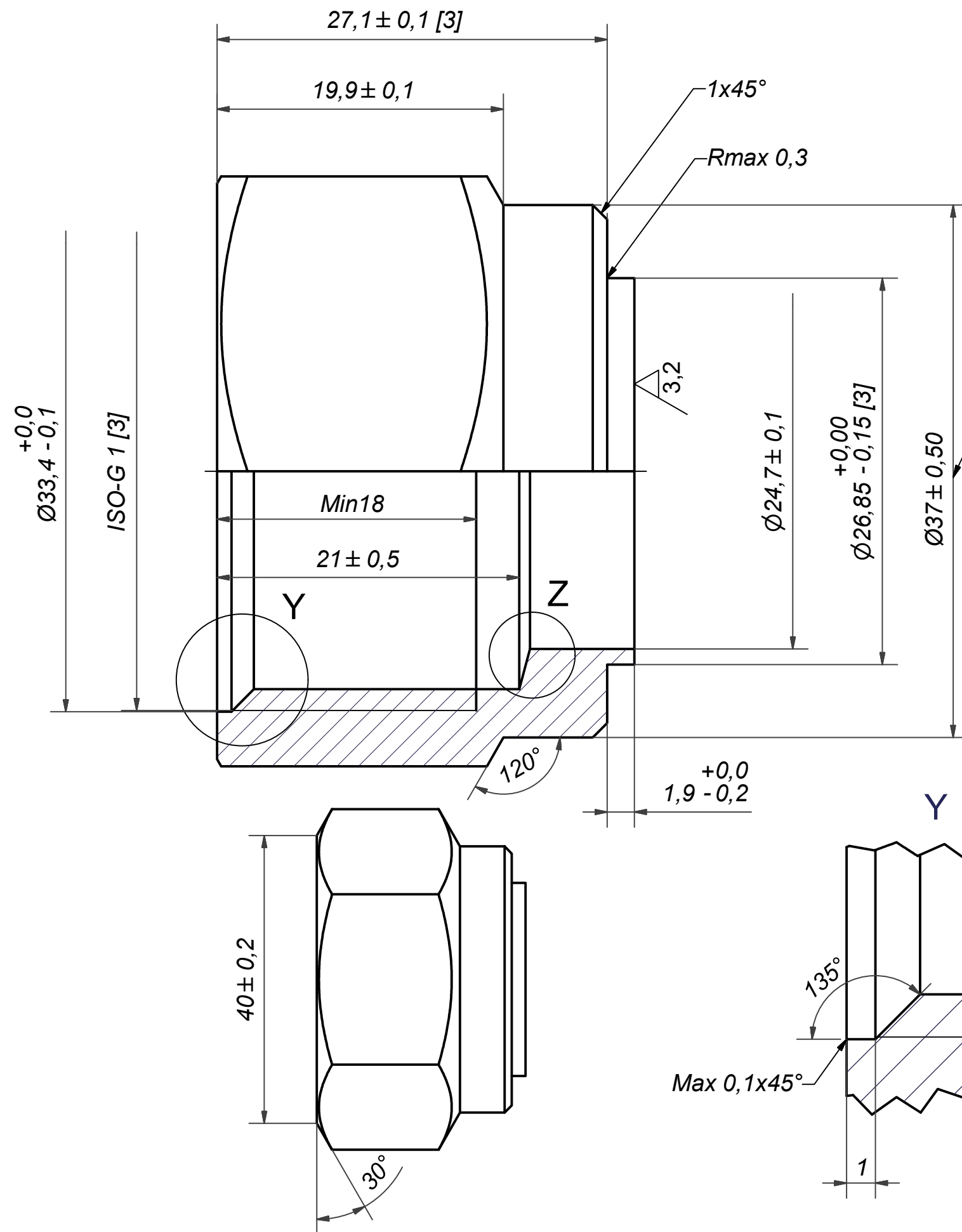

© Company Confidential, Property of SWEP International AB



**NOTE 2: DEBURR SHARP EDGES ; MAX 0,4**  
**NOTE 1:[3] - CRITICAL/SPECIAL CHARACTERISTIC TO BE FOLLOWED**

ACCORDING TO MQS  
MATERIAL

Drawn	Checked	Approved	Created Date	General geometrical tolerancing ISO 2768:	General surface finish $R_a$ :	Scale	Paper size
miguser	TP	VP	1991-11-06	m	3.2	-	A3
Title				ISO-G 1 INT. HEX.			
Article number		Design Type	Drawing number	Revision	Sheet		
-		CD	CD000001	14	1 (1)		



Rev No	Alteration	Date	Checked	Approved
07	ADDED DIMENSION. UPDATED TITLE.	24. 1. 2013	SKZE	VP

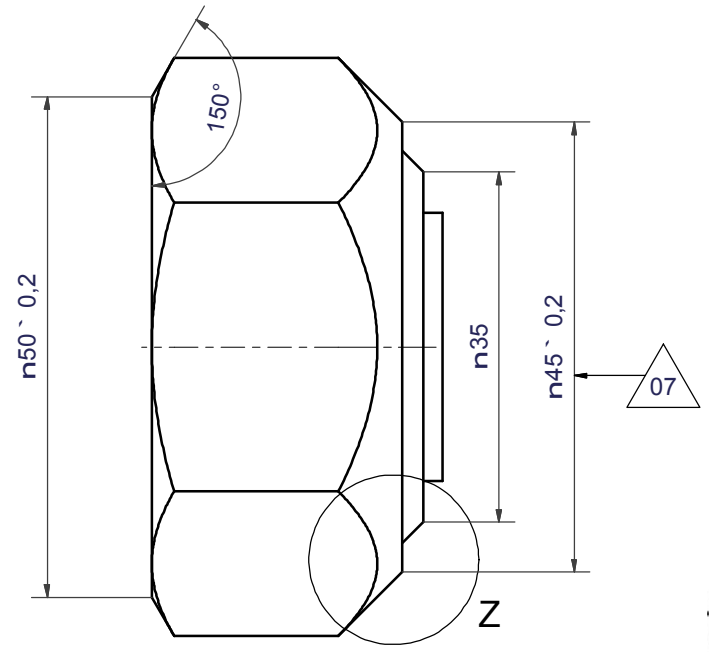
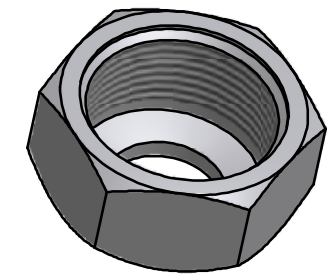
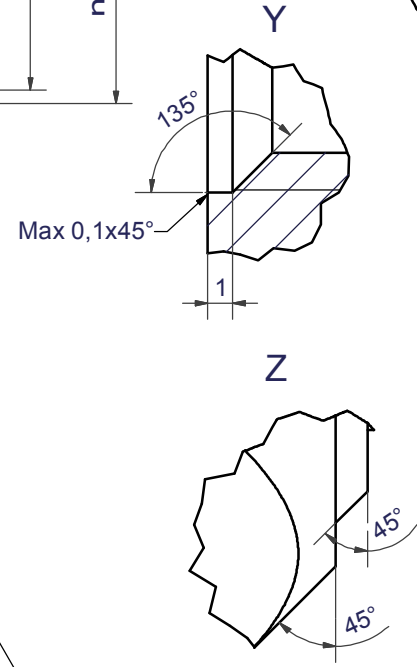
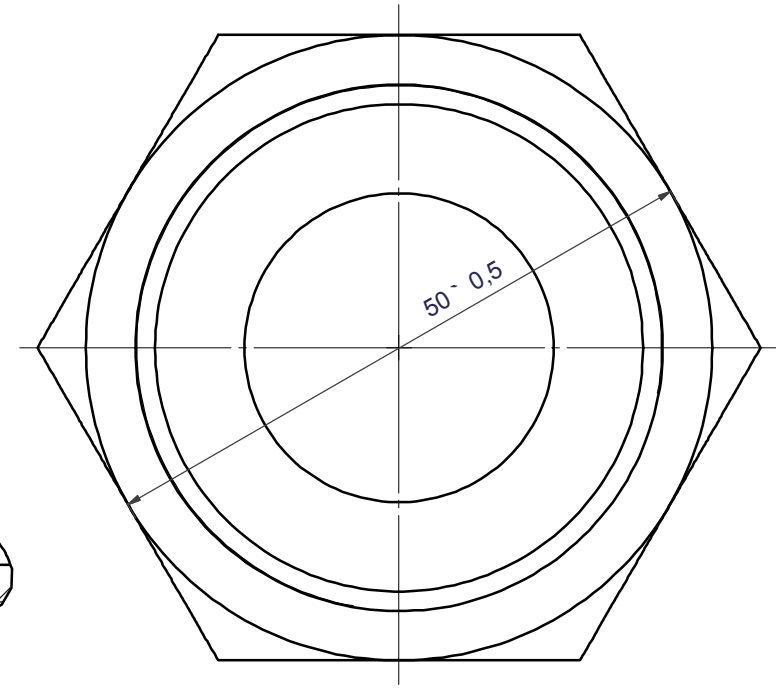
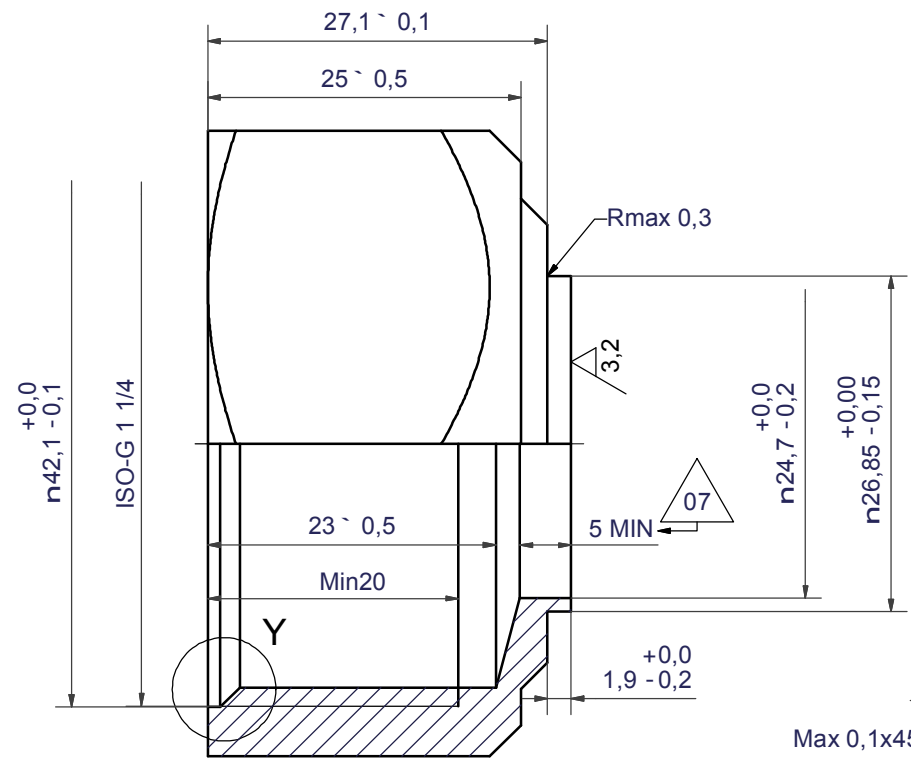

NOTE 1: DEBURR SHARP EDGES; MAX 0.4

ACCORDING TO MQS	
MATERIAL	

Drawn	Checked	Approved	Created Date	General geometrical tolerancing ISO 2768	General surface finish R <sub>a</sub>	Scale	Paper size
HR	TP	VP	31. 8. 1992	m	3.2	-	A3
Title				ISO-G 1 1/4 (INT- HEX)			
Article / Tool number		Design Type	Drawing number	Revision	Sheet		
		CD	CD000002	07	1 (1)		

