

B5T

Le B5T permet d'obtenir un échange thermique efficace dans des applications à faible débit qui exigent un espace restreint. Facile à installer et utiliser, ce produit est compact et polyvalent. C'est donc un choix bien adapté aux refroidisseurs d'eau ou d'huile de petite taille.

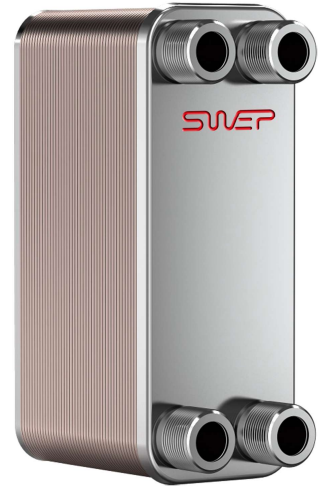

Spécifications de base

Nombre de plaques max. (NoP)	60
Débit volumétrique max.	4 m ³ /h (17.61 gpm)
Volume du canal	0.024/0.024 dm ³ (0.0008/0.0008 ft ³)
Matières	Plaques en acier inoxydable 316, brasage cuivre
Poids sans les connexions	0.50+(0.044*NoP) kg 1.09+(0.097*NoP) lb

Les dimensions standard

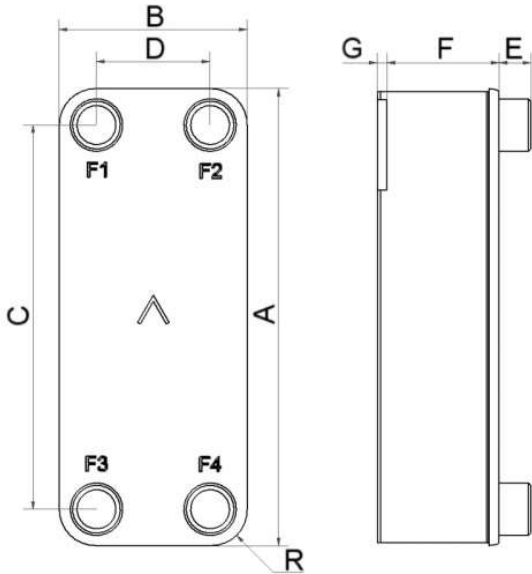

#	MM	IN
A	193	7.6
B	76	2.99
C	154	6.06
D	40	1.57
F	4.00+2.24*(NoP)	0.16+0.09*(NoP)
G	6.20	0.24
R	18	0.71
E_1	20	0.79

PED pression / température

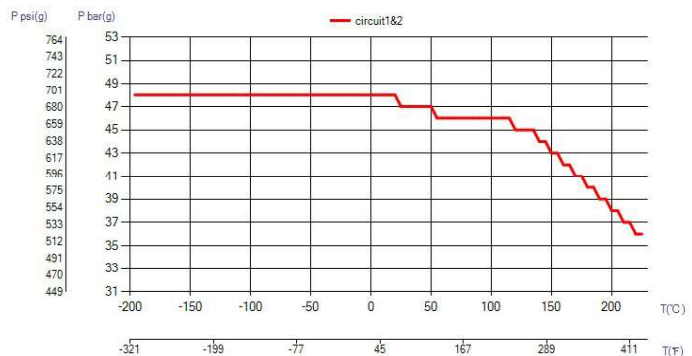

ÉCHANGEURS THERMIQUES

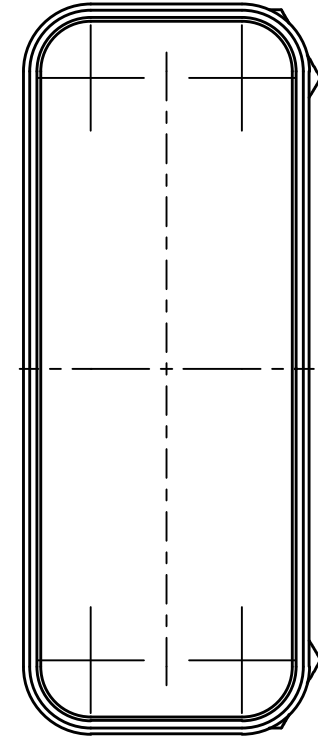
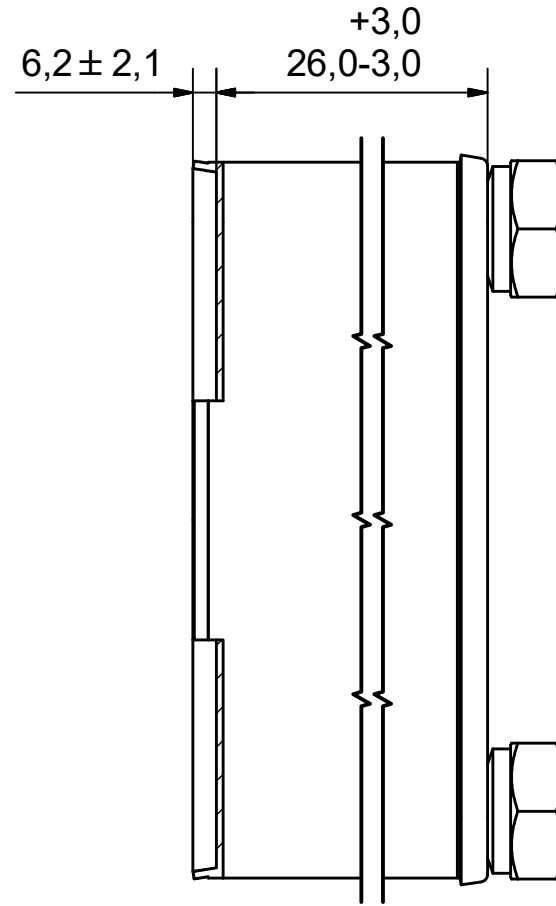
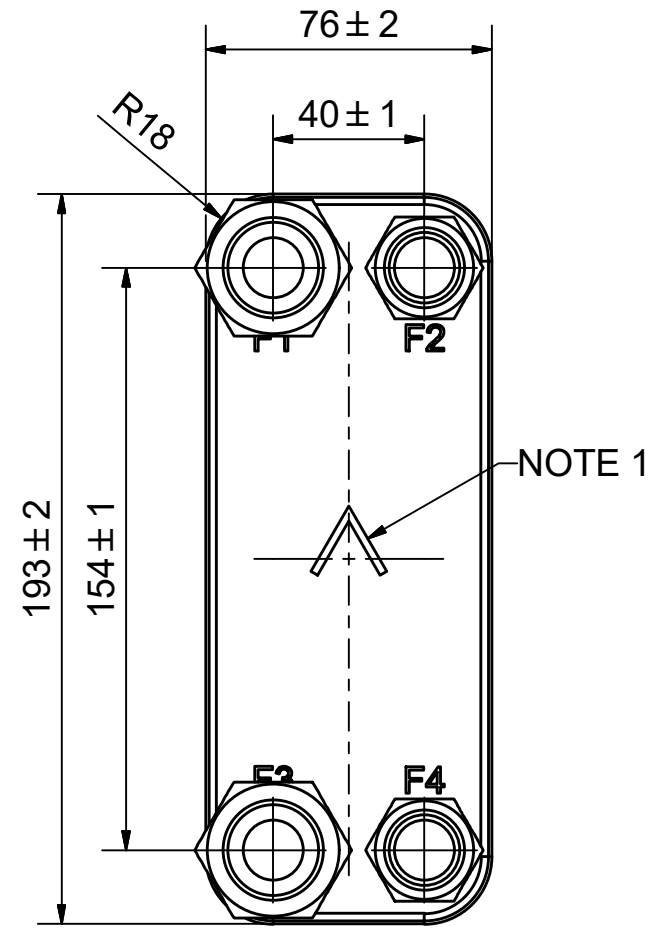
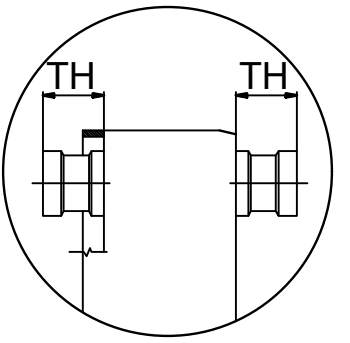



NOTE 1 ALTERNATE MARKING: STICKER OR STAMP

AXINTRA
ÉCHANGEURS THERMIQUES

F4	45411	ISO-G 1/2 INT HEX, TH = 20,1	CD000005
F3	45429	ISO-G 3/4, TH = 20,1	CD000007
F2	45411	ISO-G 1/2 INT HEX, TH = 20,1	CD000005
F1	45429	ISO-G 3/4, TH = 20,1	CD000007

Pos	Article No	Title / Denomination, code, material, dimension etc	Drawing No./ref	Pos	Article No	Title / Denomination, code, material, dimension etc	Drawing No./ref
-----	------------	---	-----------------	-----	------------	---	-----------------

B5T

Title		B5TH/1P-SC-M	
 A DOVER COMPANY	Created Date	Created By	
	2018-02-22	AU	
Article/Configuration number		Drawing number	
14627-010		AU00352263	

Rev No.	Alteration	Date	Checked	Approved
10	REDRAWN IN INVENTOR	2004/07/06	TN	PDM

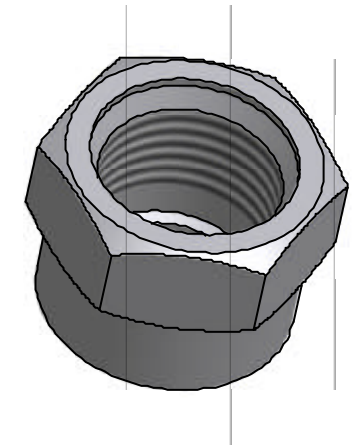
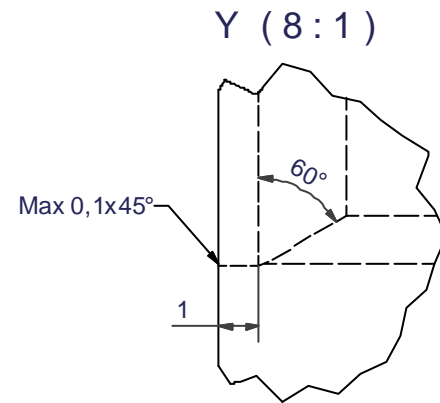
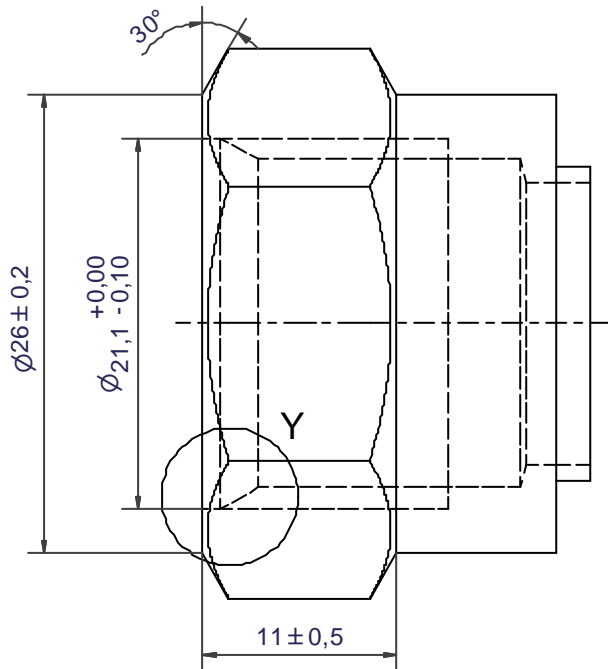
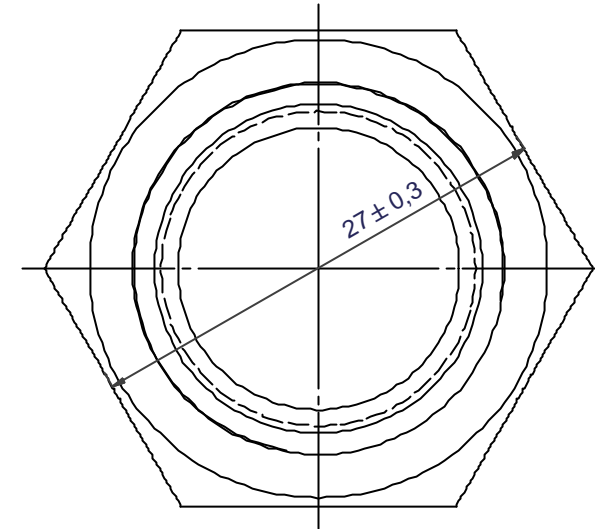
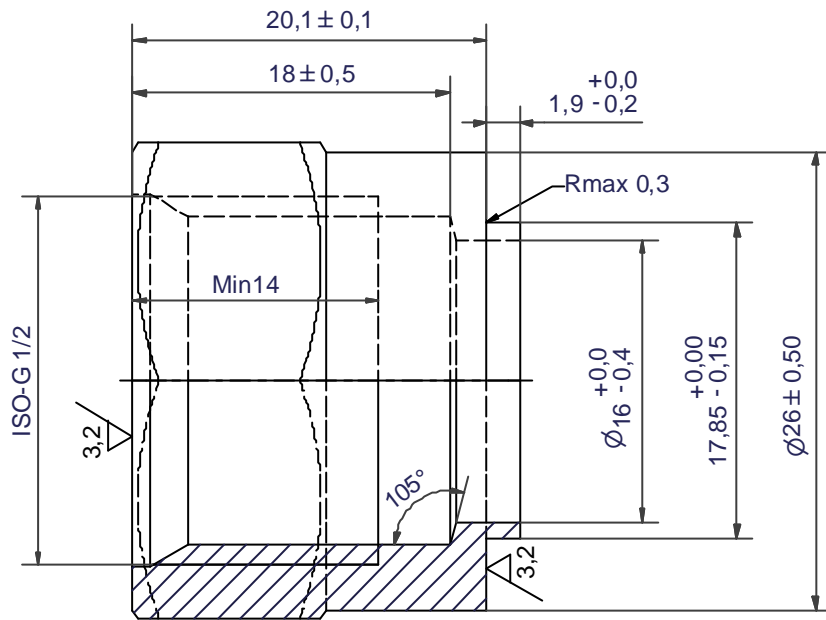

AXINTRA
ÉCHANGEURS THERMIQUES

Drawn HR	Checked TP	Approved VP	Created Date 1992/05/05	General geometrical tolerancing ISO 2768 m	General surface finish R_a 3.2		Scale 7:2
			ISO-G 1/2 INT HEX				
Article number -			Drawing number CD000005	Revision 10	Sheet 1 (1)		

