

B85

Le B85 est un échangeur thermique extrêmement performant. La performance thermique du B85 est supérieure à celle de tout autre produit comparable. Le B85 est le choix idéal pour les condensateurs à haute performance et les applications de transfert thermique exigeantes. Ses larges ports lui permettent d'accepter des capacités élevées. Avec sa profondeur de pressage inférieure à celle des générations précédentes, fait que le B85 est plus compact et performant.



Spécifications de base

Nombre de plaques max. (NoP)	160
Débit volumétrique max.	17 m ³ /h (74.85 gpm)
Volume du canal	0.094/0.094 dm ³ (0.0033/0.0033 ft ³)
Matières	Plaques en acier inoxydable 316, brasage cuivre
Poids sans les connexions	2.09+(0.1367*NoP) kg 4.60+(0.301*NoP) lb

Les dimensions standard

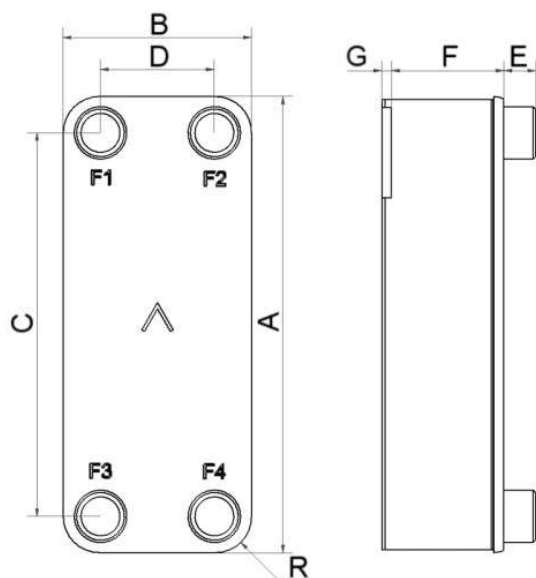

#	MM	IN
A	526	20.71
B	119	4.69
C	470	18.5
D	63	2.48
F	4.00+1.84*(NoP)	0.16+0.07*(NoP)
G	6	0.24
R	23	0.91
E_1	27	1.06

PED pression / température

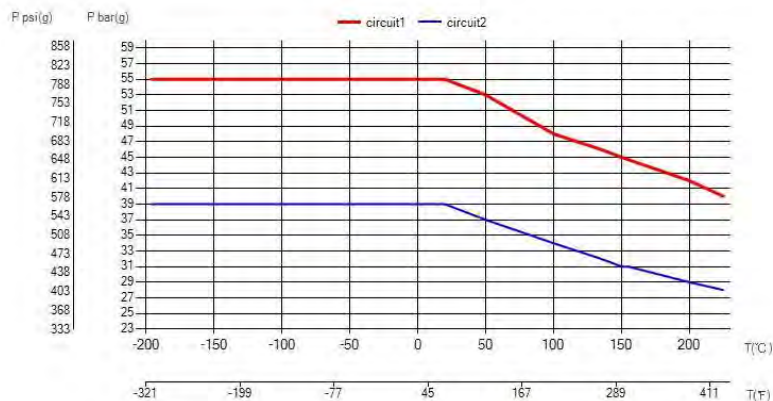

AXINTRA

ÉCHANGEURS THERMIQUES

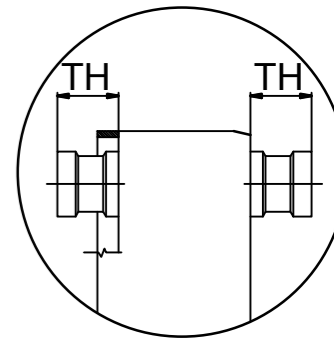
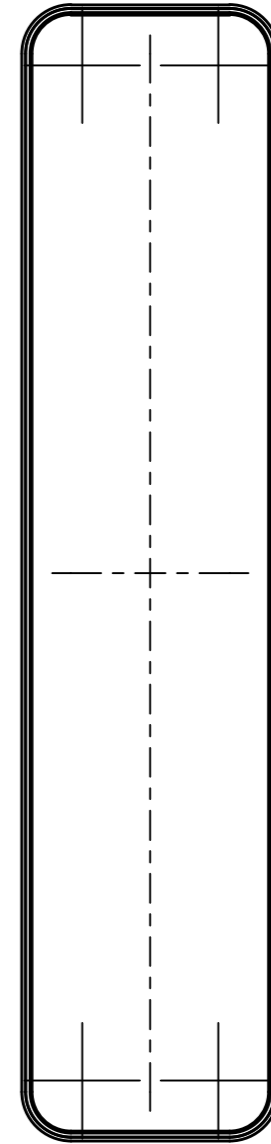
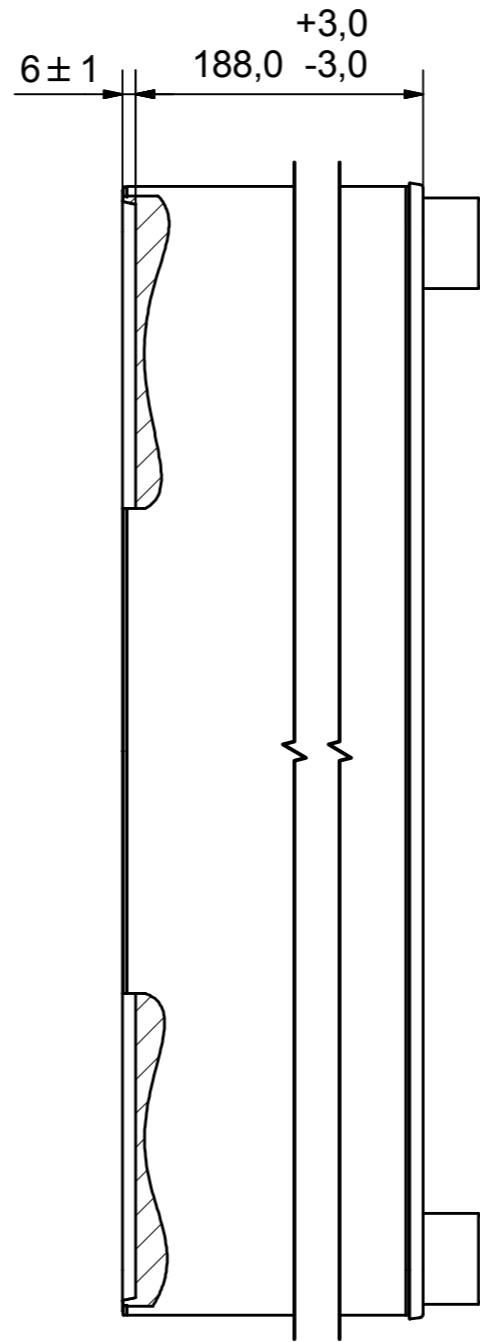
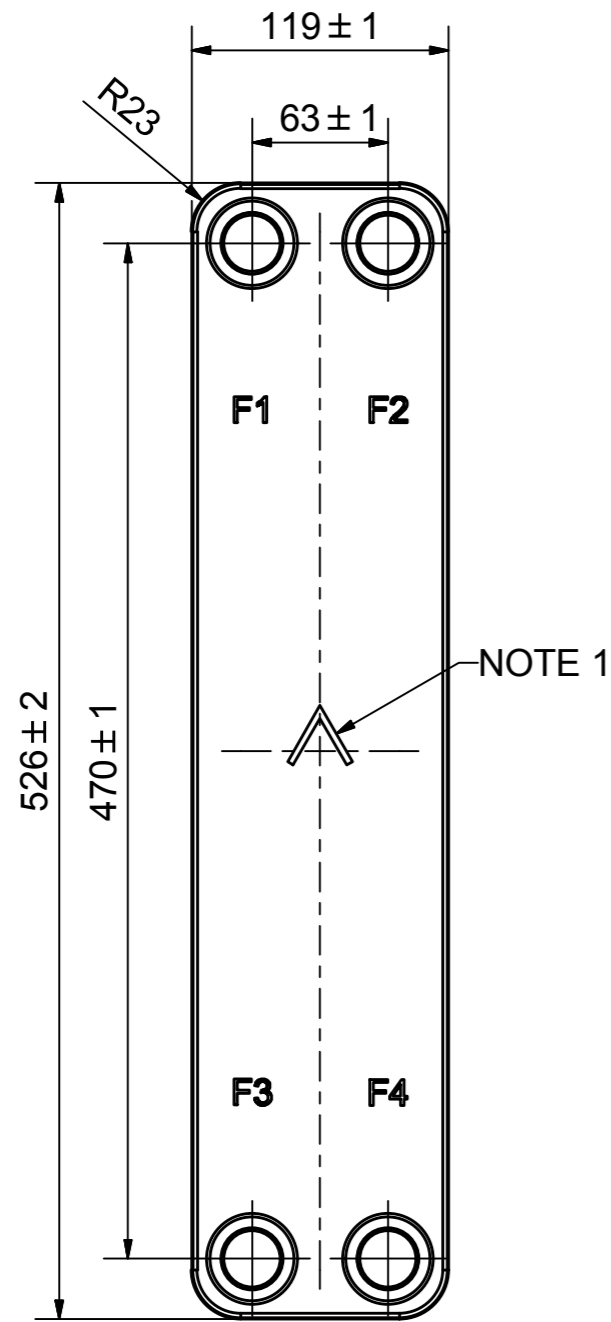

AXINTRA

ÉCHANGEURS THERMIQUES

NOTE 1 ALTERNATE MARKING: STICKER OR STAMP

F4	32567	ISO-G 1 1/4" A & SOLDER 28U, TH =	CD000807
F3	32567	ISO-G 1 1/4" A & SOLDER 28U, TH =	CD000807
F2	32567	ISO-G 1 1/4" A & SOLDER 28U, TH =	CD000807
F1	32567	ISO-G 1 1/4" A & SOLDER 28U, TH =	CD000807

Pos	Article No	Title / Denomination, code, material, dimension etc	Drawing No./ref	Pos	Article No	Title / Denomination, code, material, dimension etc	Drawing No./ref
	27,1						

Title		B85H/1P-SC-M	
		Created Date	2018-05-22
		Created By	AU
		Article/Configuration number	17127-100
		Drawing number	AU00380363

Rev No.	Alteration	Date	Checked	Approved
1	CHANGED DENOMIATION	2007/05/28	ANL	PDM

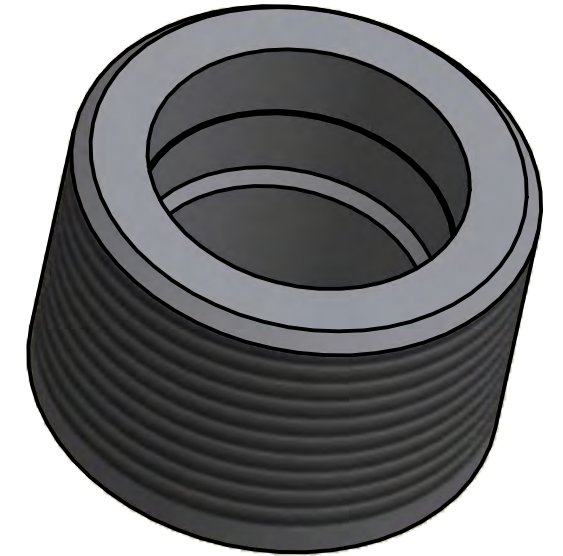
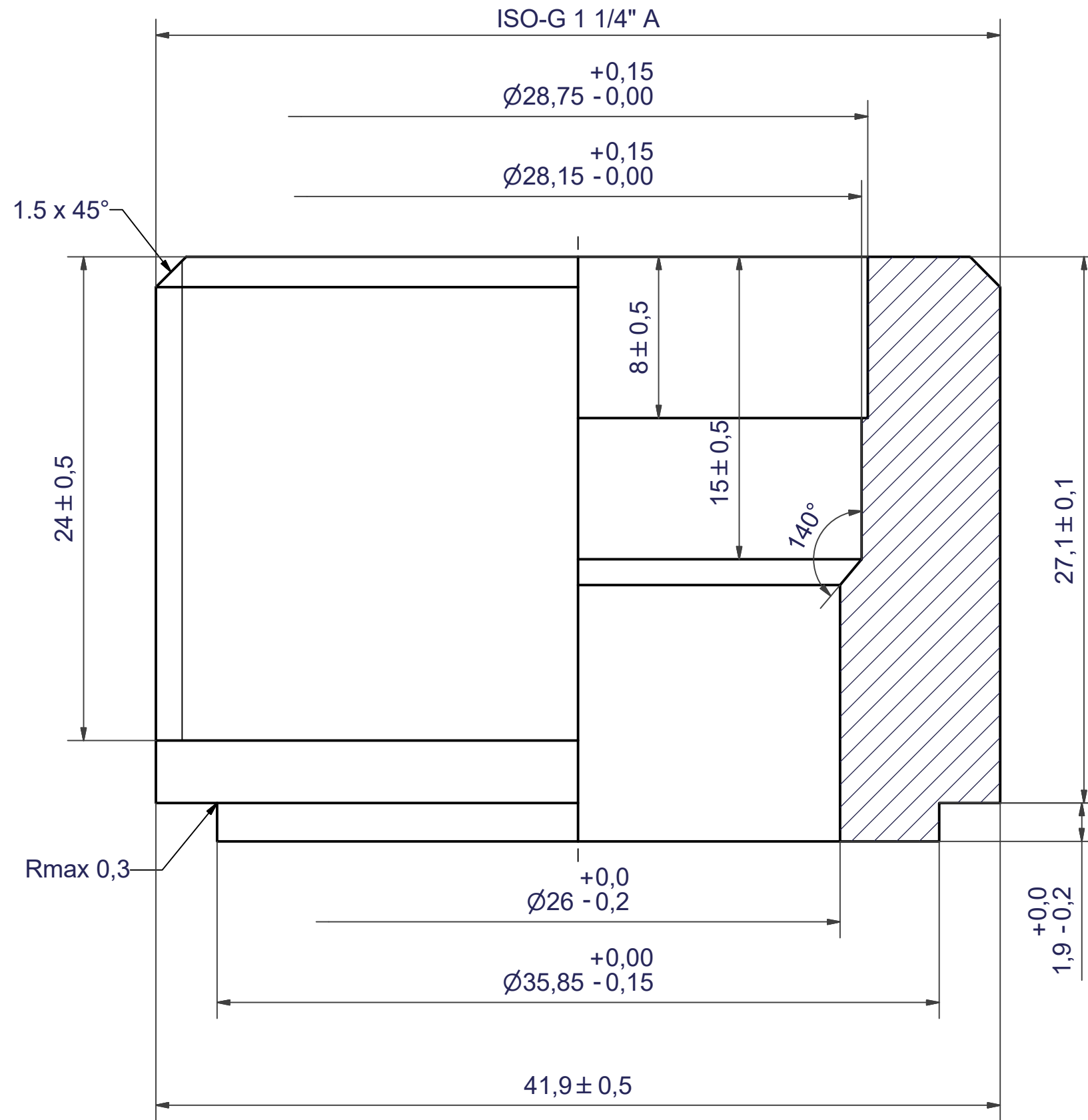

ACCORDING TO MQS
MATERIAL

Drawn lathe	Checked PDM	Approved PDM	Created Date 5/9/2006	General geometrical tolerancing ISO 2768 m	General surface finish R_a 3.2	Scale 4:1
			Title ISO-G 1 1/4" A & SOLDER 28U			
			Article number 2018-10-11	Drawing number CD000807	Revision 03	Sheet 1 (1)

© Company Confidential, Property of SWEPP International AB

AXINTRA
ÉCHANGEURS THERMIQUES

New