

# V80

L'évaporateur V80 a été développé pour offrir une performance très efficace dans une gamme étendue d'applications. Il fonctionne dans un large intervalle de capacités, ce qui fait de ce modèle le choix évident pour la plupart des applications d'évaporateur.



## Spécifications de base

Nombre de plaques max. (NoP)	140
Débit volumétrique max.	16,9 m <sup>3</sup> /h (39.63 gpm)
Volume du canal	0.107/0.107 dm <sup>3</sup> (0.0038/0.0038 ft <sup>3</sup> )
Matières	Plaques en acier inoxydable 316, brasage cuivre
Poids sans les connexions	2.09+(0.194*NoP) kg 4.61+(0.428*NoP) lb

## Les dimensions standard

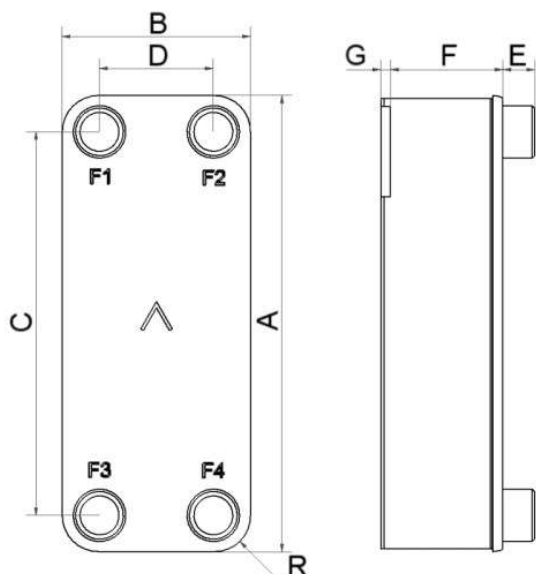

#	MM	IN
A	526	20.71
B	119	4.69
C	470	18.5
D	63	2.48
F	4.00+2.24*(NoP)	0.16+0.09*(NoP)
G	6	0.24
R	23	0.91
E_1	27	1.06

## PED pression / température

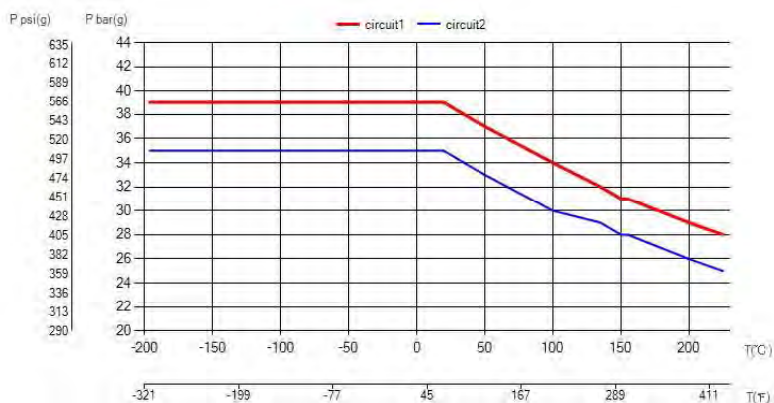

**AXINTRA**

ÉCHANGEURS THERMIQUES

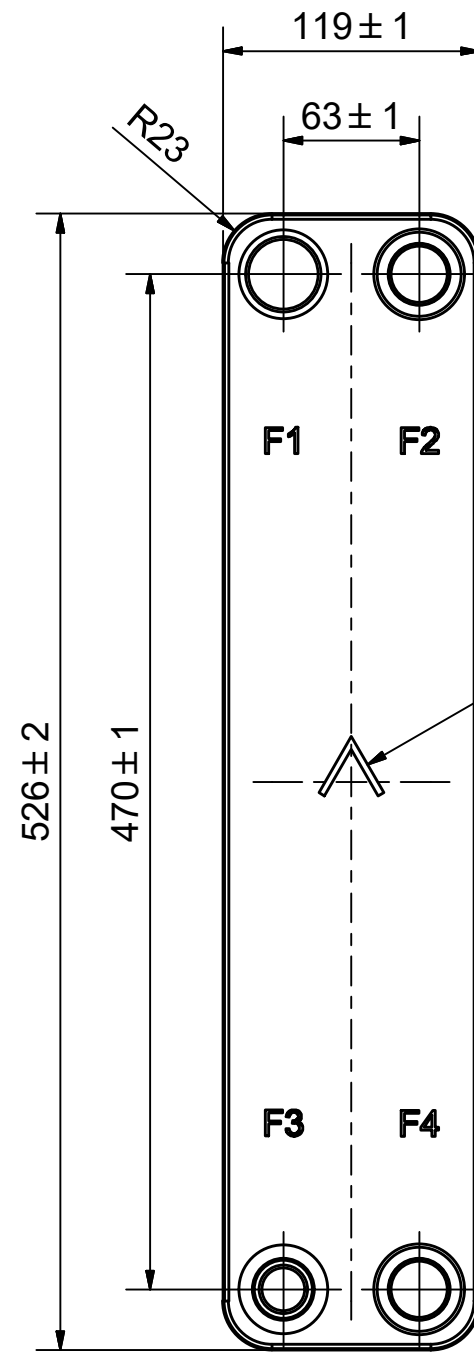

NOTE 1

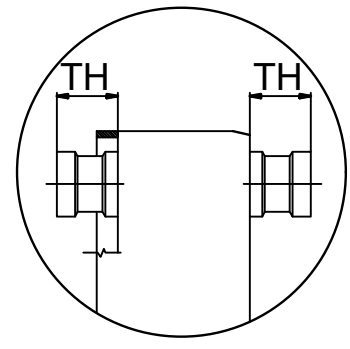
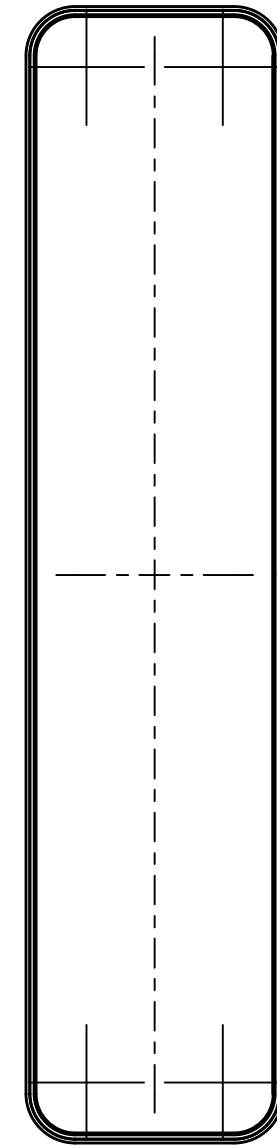
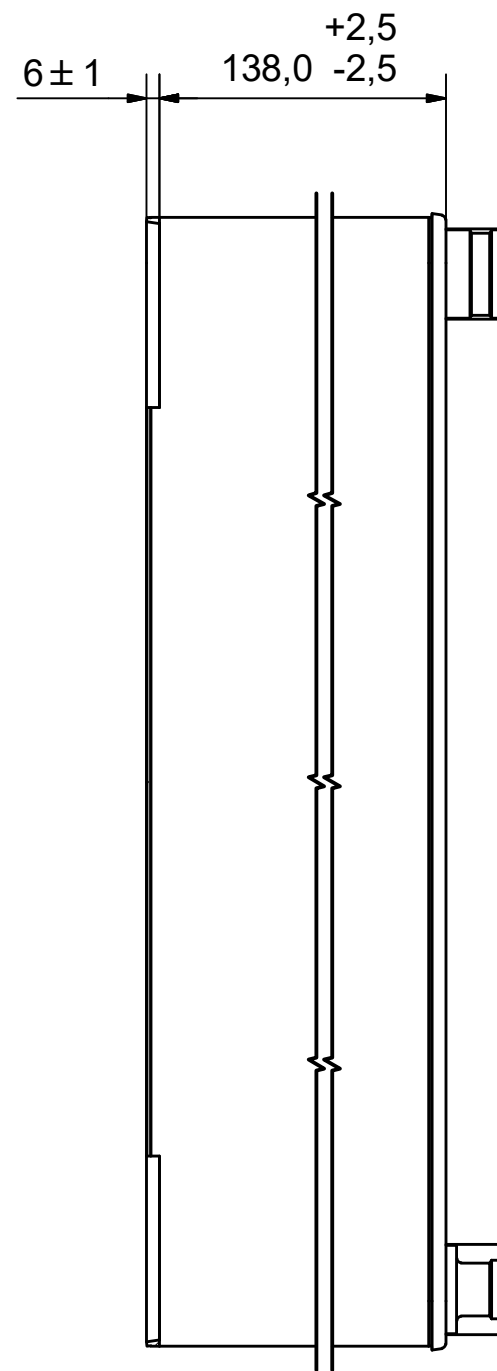

NOTE 1 ALTERNATE MARKING: STICKER OR STAMP

F4	32567	ISO-G 1 1/4" A & SOLDER 28U, TH =	CD000807
F3	45652	<del>SOLDER</del> 22U, TH = 27,1	CD000204
F2	32567	ISO-G 1 1/4" A & SOLDER 28U, TH =	CD000807
F1	45608	<del>SOLDER</del> ø35,1, TH = 27,1	CD000192

Pos	Article No	Title / Denomination, code, material, dimension etc	Drawing No./ref	Pos	Article No	Title / Denomination, code, material, dimension etc	Drawing No./ref
-----	------------	---	-----------------	-----	------------	---	-----------------

Title		V80H/1P-SC-S	
 A DOVER COMPANY		Created Date	2018-05-02
		Created By	AU
Article/Configuration number		14238-060	
Drawing number		AU00373391	

Rev No.	Alteration	Date	Checked	Approved
4	REDRAWN IN INVENTOR	2004/07/14	TN	PDM

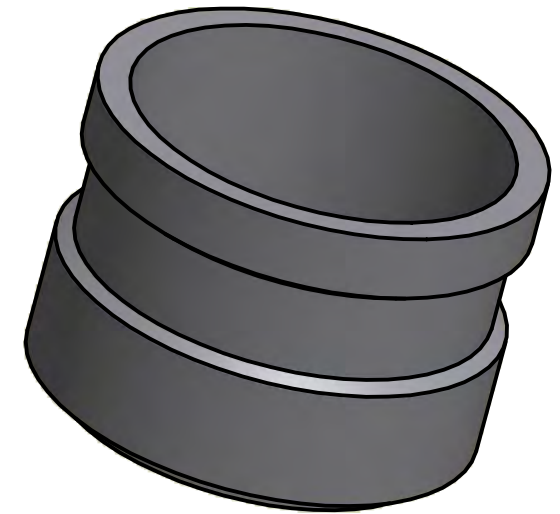
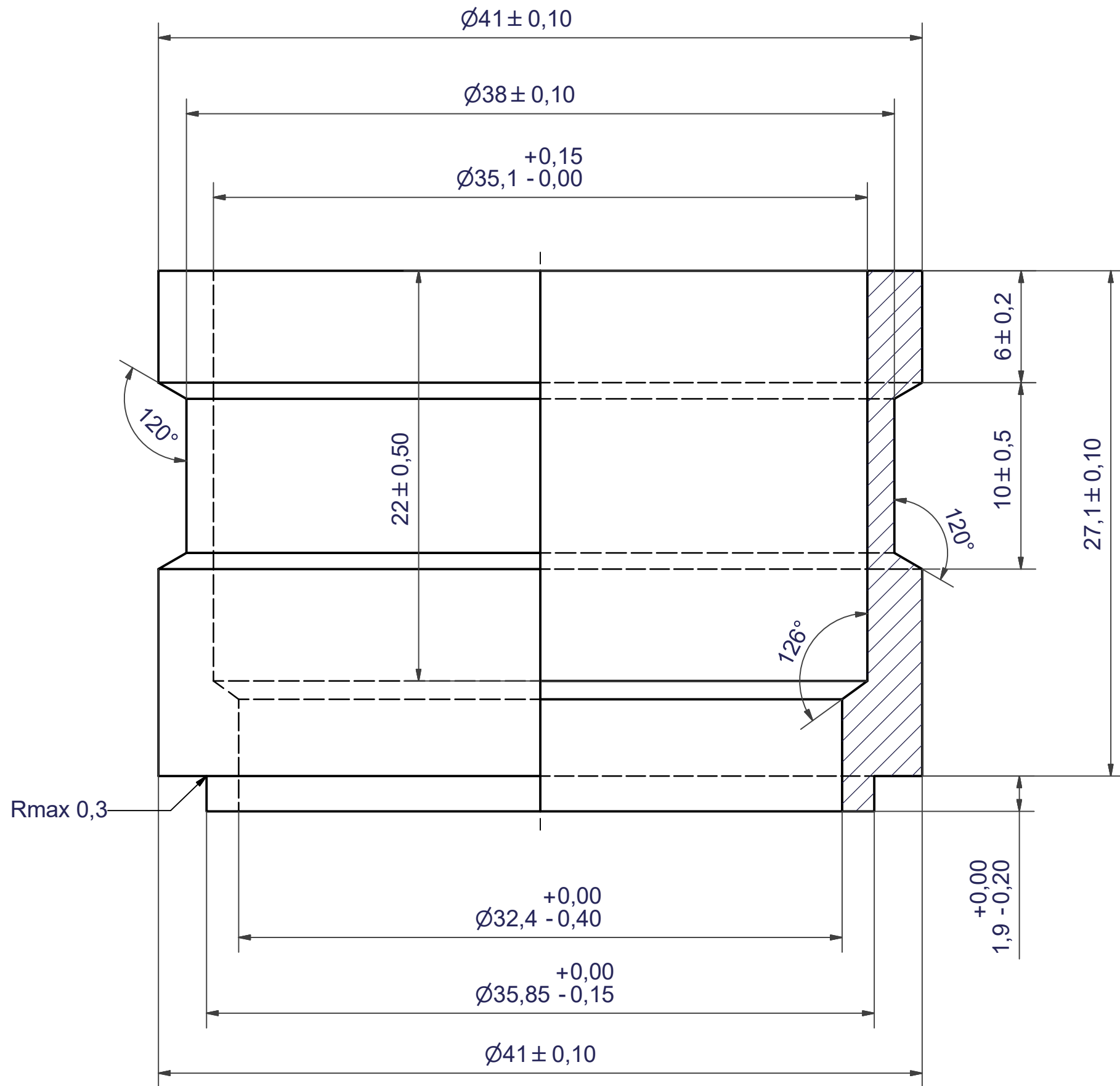

© Company Confidential, Property of SWEP International AB

**AXINTRA**  
ÉCHANGEURS THERMIQUES

Drawn lathe	Checked HR	Approved BOS	Created Date 1994-11-18	General geometrical tolerancing ISO 2768	General surface finish $R_a$		Scale -
 A DOVER COMPANY			Title <b>SOLDER <math>\varnothing 35,1</math></b>				
			Article number	Drawing number CD000192	Revision 04	Sheet 1 (1)	

Rev No.	Alteration	Date	Checked	Approved
4	REDRAWN IN INVENTOR	2004/07/08	TN	PDM

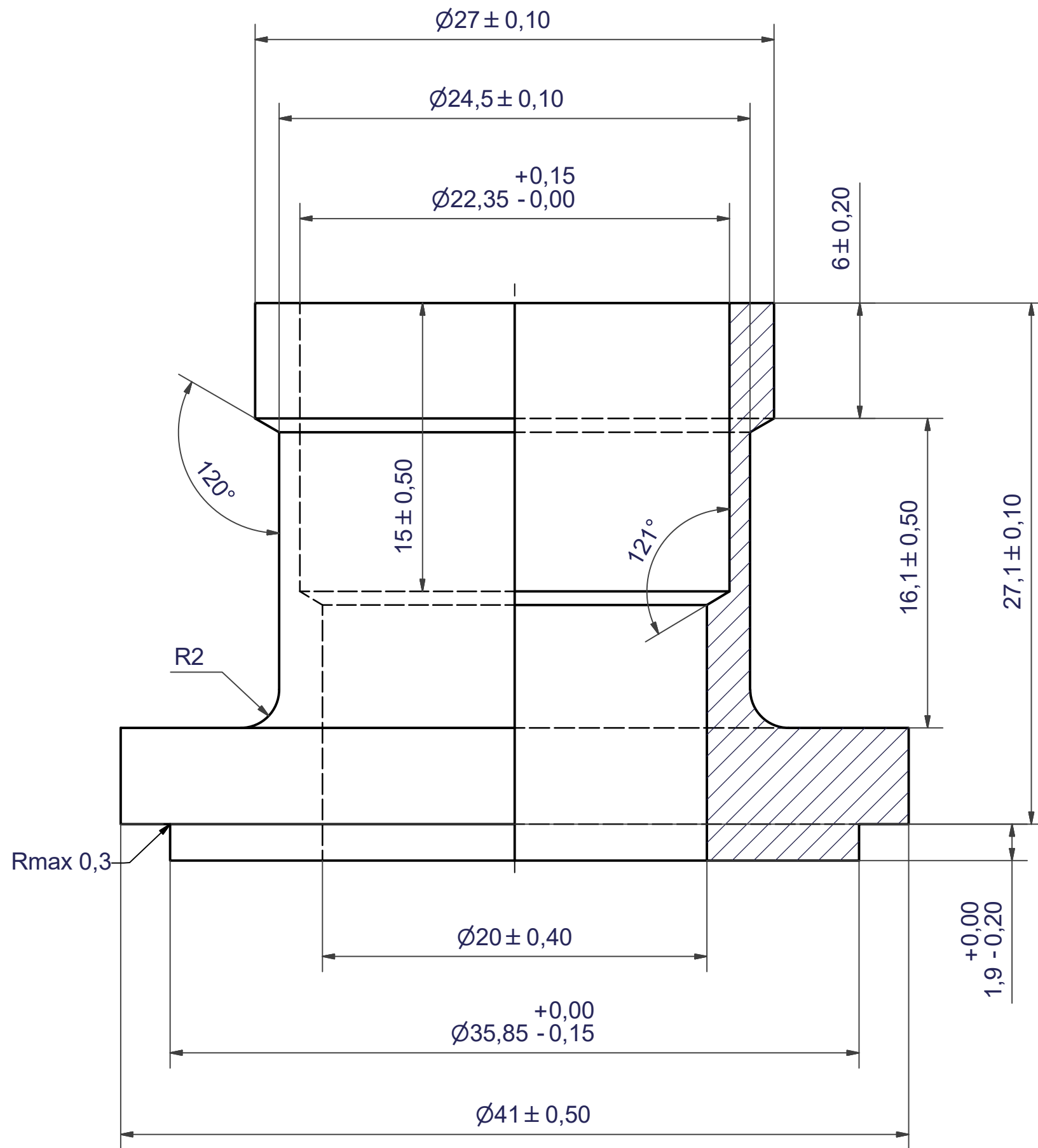

© Company Confidential, Property of SWEP International AB

**AXINTRA**  
ÉCHANGEURS THERMIQUES

Drawn miguser	Checked HR	Approved BOS	Created Date 1994-12-20	General geometrical tolerancing ISO 2768	General surface finish $R_a$		Scale -
			Title <b>SOLDER 22U</b>				
A DOVER COMPANY			Article number	Drawing number CD000204	Revision 04	Sheet 1 (1)	

Rev No.	Alteration	Date	Checked	Approved
1	CHANGED DENOMINATION	2007/05/28	ANL	PDM

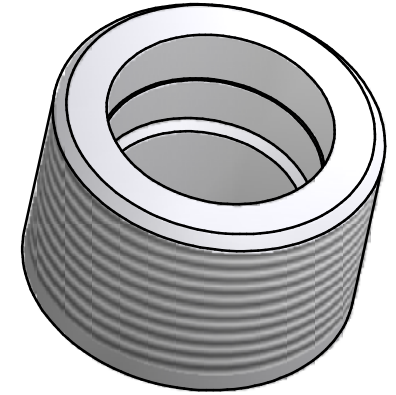
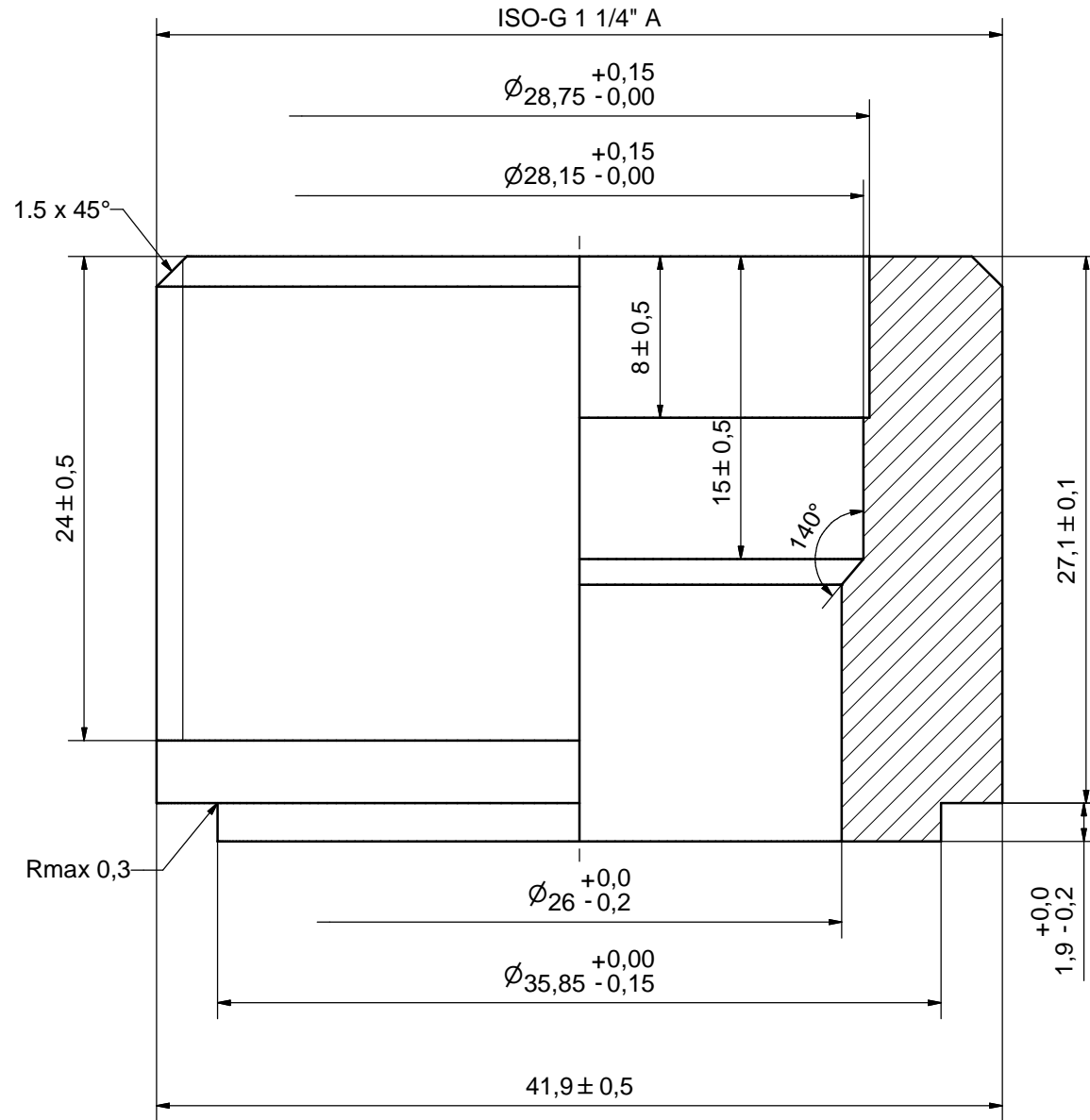

ACCORDING TO MQS  
MATERIAL

Drawn	Checked	Approved	Created Date	General geometrical tolerancing ISO 2768	General surface finish $R_a$	Scale
THE	PDM	PDM	2006/05/09	m	3.2	4:1
Title				ISO-G 1 1/4" A & SOLDER 28U		
Article number		Drawing number		Revision	Sheet	
-		CD000807		1	1 (1)	

© Company Confidential, Property of SWEP International AB

**AXINTRA**  
ÉCHANGEURS THERMIQUES

**SWEP**  
A DOVER COMPANY