

B80S- All Stainless

Le B80S est notre modèle haute capacité de la gamme d'échangeurs de taille moyenne. Il est le choix idéal pour la plupart des types d'applications de refroidisseur à basse capacité et des pompes à chaleur haute performance. Il couvre une large gamme de capacités dans les sous-stations de chauffage collectif et il est un refroidisseur d'huile éprouvé pour les compresseurs et composants hydrauliques.



Spécifications de base

Nombre de plaques max. (NoP)	140
Débit volumétrique max.	17 m³/h (74.85 gpm)
Volume du canal	0.107/0.107 dm³ (0.0038/0.0038 ft³)
Matières	Plaques en acier inoxydable 316, brasage acier inoxydable
Poids sans les connexions	2.18+(0.231*NoP) kg 4.80+(0.509*NoP) lb

Les dimensions standard

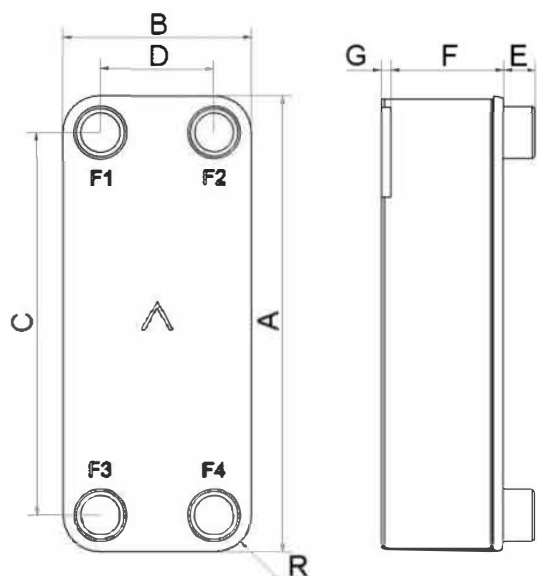

#	MM	IN
A	526	20.71
B	119	4.69
C	470	18.5
D	63	2.48
F	4.00+2.39*(NoP)	0.16+0.09*(NoP)
G	6	0.24
R	23	0.91
E_1	27	1.06

PED pression / température

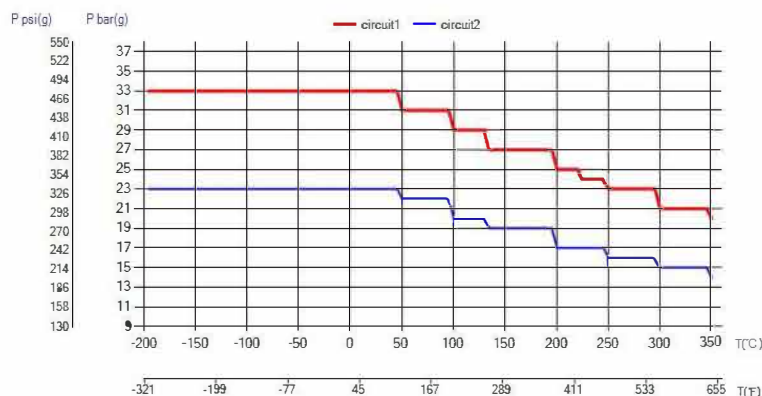

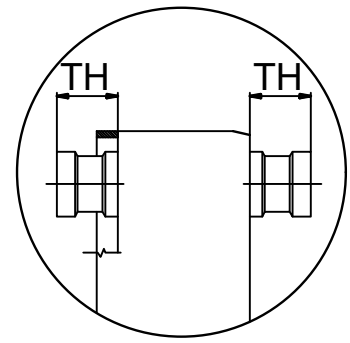
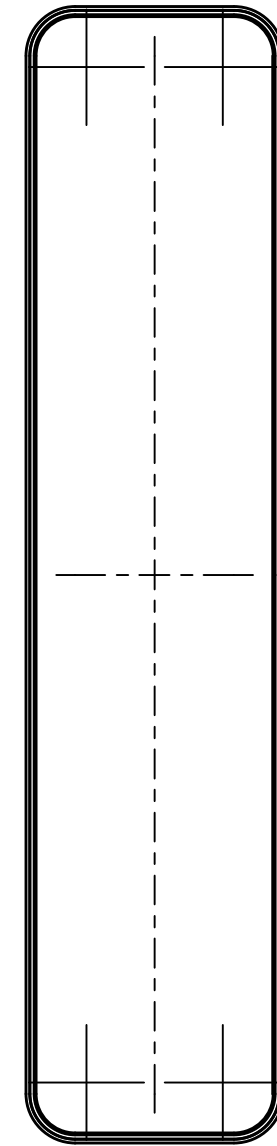
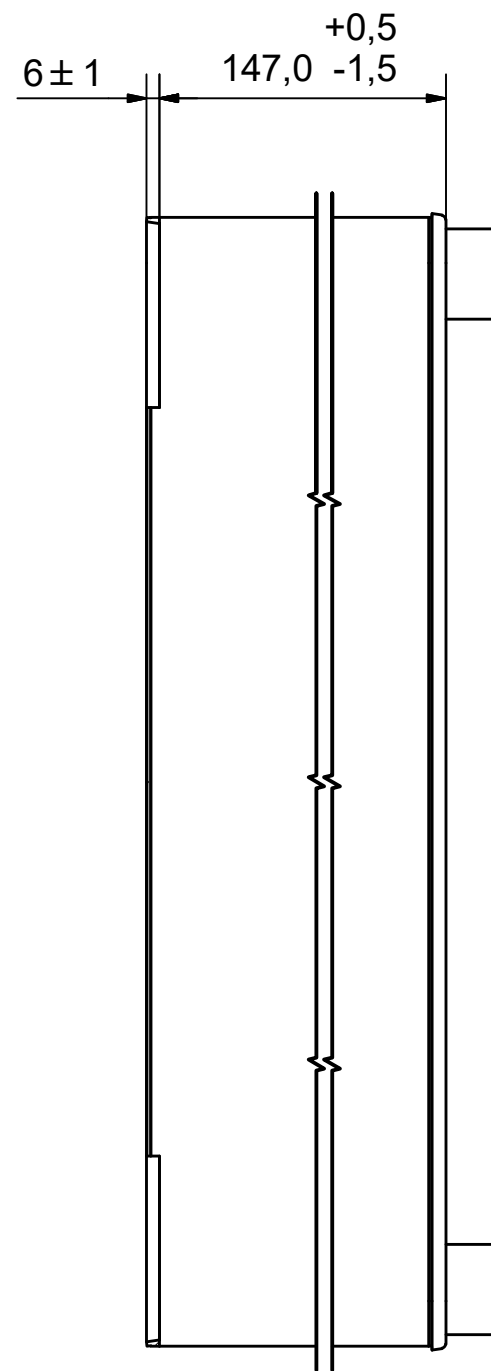
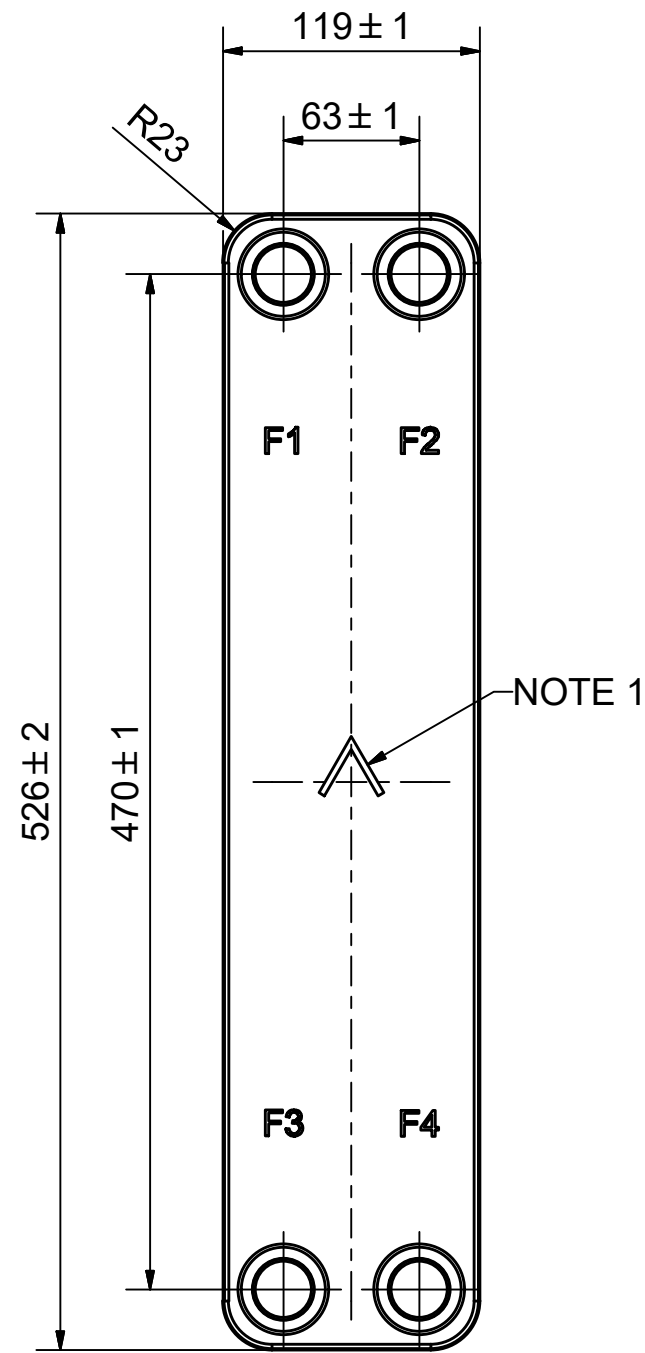

AXINTRA
ÉCHANGEURS THERMIQUES

NOTE 1 ALTERNATE MARKING: STICKER OR STAMP

F4	32567	ISO-G 1 1/4" A & SOLDER 28U, TH =	CD000807
F3	32567	ISO-G 1 1/4" A & SOLDER 28U, TH =	CD000807
F2	32567	ISO-G 1 1/4" A & SOLDER 28U, TH =	CD000807
F1	32567	ISO-G 1 1/4" A & SOLDER 28U, TH =	CD000807

Pos	Article No	Title / Denomination, code, material, dimension etc	Drawing No./ref	Pos	Article No	Title / Denomination, code, material, dimension etc	Drawing No./ref
	27,1						

Title		B80SH/1P-SPS-M	
 A DOVER COMPANY	Created Date	2019-01-21	Created By
	Article/Configuration number	16640-060	Drawing number
			AU
			AU00453015

Rev No.	Alteration	Date	Checked	Approved
1	CHANGED DENOMINATION	2007/05/28	ANL	PDM

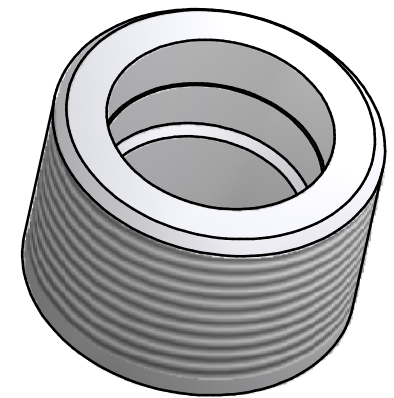
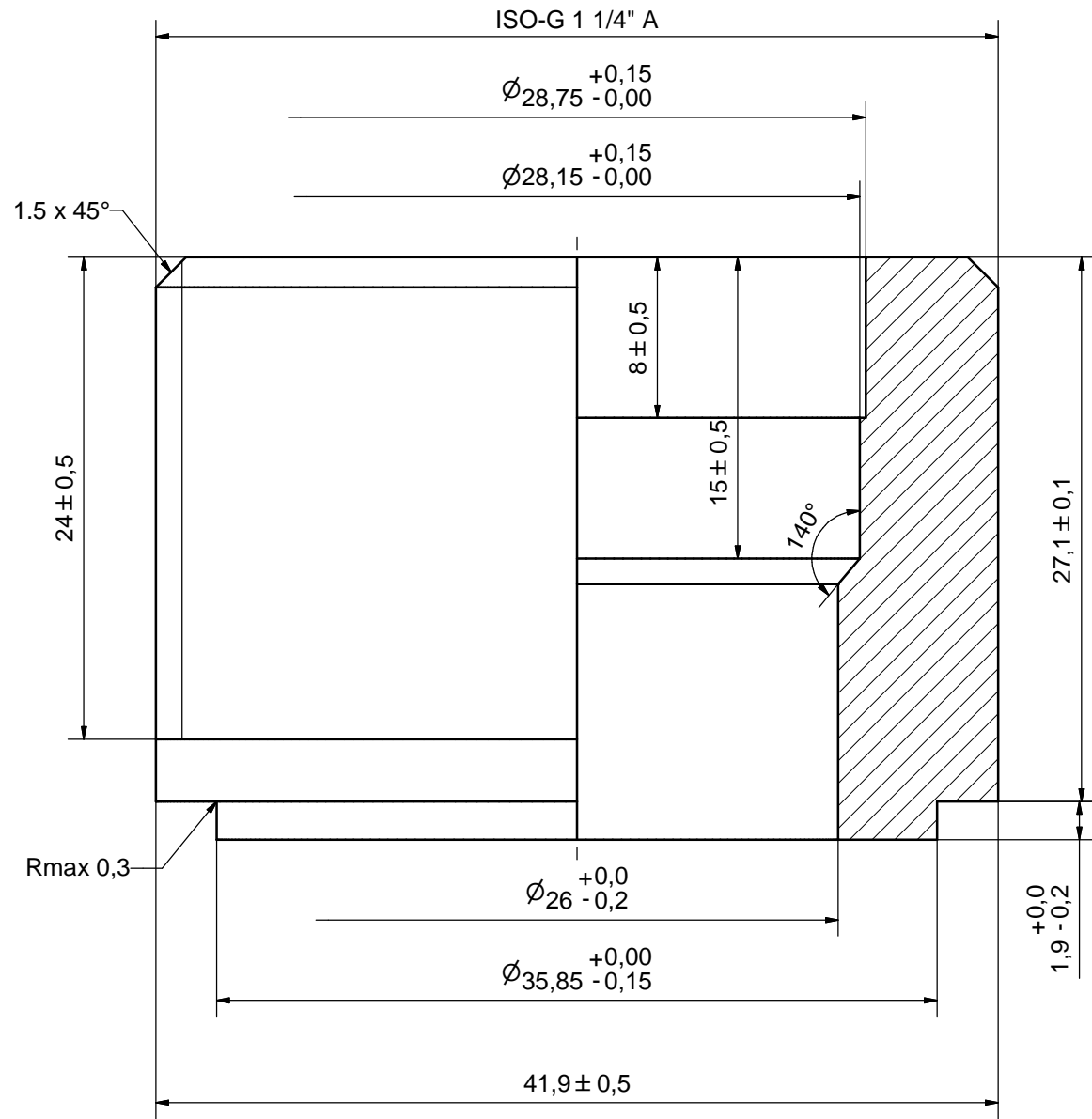

ACCORDING TO MQS
MATERIAL

Drawn	Checked	Approved	Created Date	General geometrical tolerancing ISO 2768	General surface finish R_a	Scale
THE	PDM	PDM	2006/05/09	m	3.2	4:1
Title				ISO-G 1 1/4" A & SOLDER 28U		
Article number		Drawing number		Revision	Sheet	
-		CD000807		1	1 (1)	

© Company Confidential, Property of SWEP International AB

