

# B26

Intégrant des canaux AsyMatrix®, le condensateur B26 est conçu pour offrir de hautes performances, qui en font le choix idéal pour les applications de pompes à chaleur. Notre technologie AsyMatrix® combine un échangeur thermique très performant avec de faibles pertes de charge. Elle permet aux fabricants d'obtenir des systèmes à la fois plus compacts et plus efficaces. Grâce à sa haute performance, à son volume interne faible et à son encombrement réduit, ce BPHE occupe une position unique sur le marché en apportant une réponse parfaite aux besoins de nombreuses applications et fonctions.



## Spécifications de base

Nombre de plaques max. (NoP)	160
Débit volumétrique max.	11,3 m <sup>3</sup> /h (13.21 gpm)
Volume du canal	0.044/0.066 dm <sup>3</sup> (0.0016/0.0023 ft <sup>3</sup> )
Matières	Plaques en acier inoxydable 316, brasage cuivre
Poids sans les connexions	1.49+(0.1076*NoP) kg 3.29+(0.237*NoP) lb

## Les dimensions standard

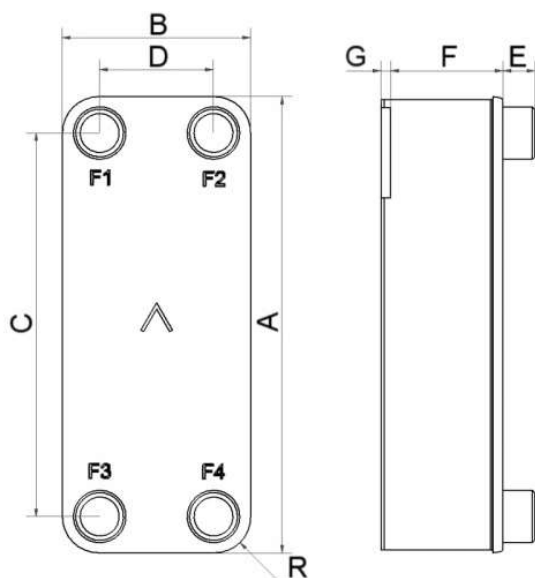

#	MM	IN
A	376	14.8
B	119	4.69
C	329	12.95
D	72	2.83
F	4.00+1.61*(NoP)	0.16+0.06*(NoP)
G	6	0.24
R	23	0.91
E_1	20	0.79

## PED pression / température

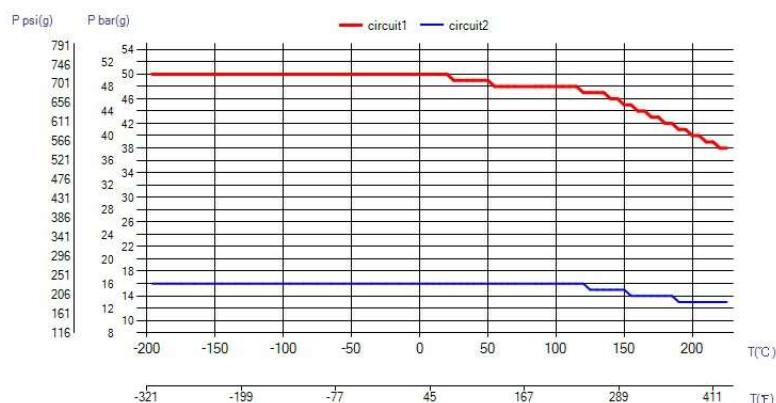

ÉCHANGEURS THERMIQUES

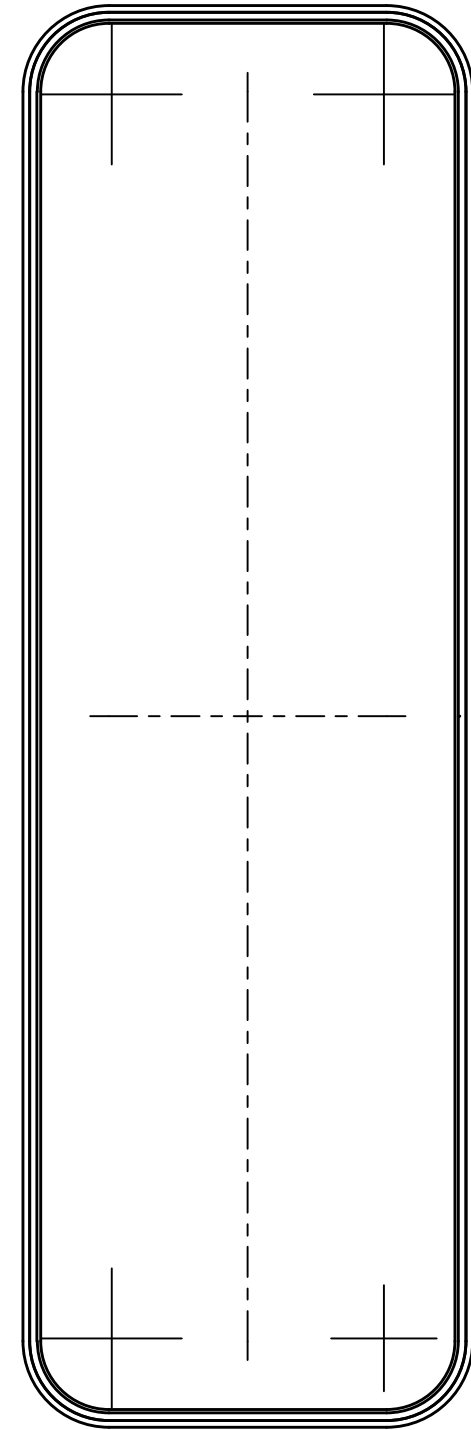
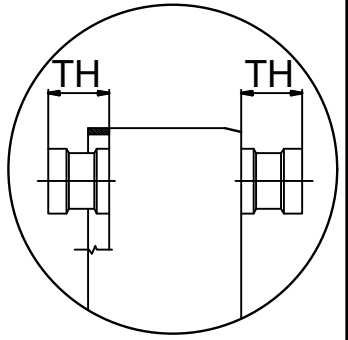
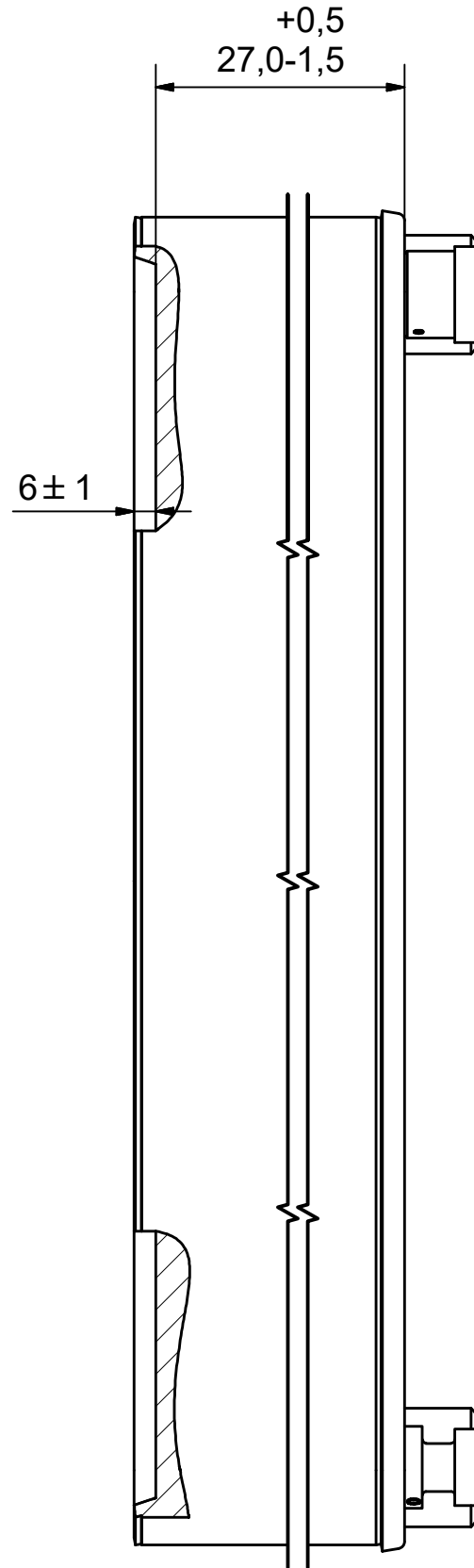
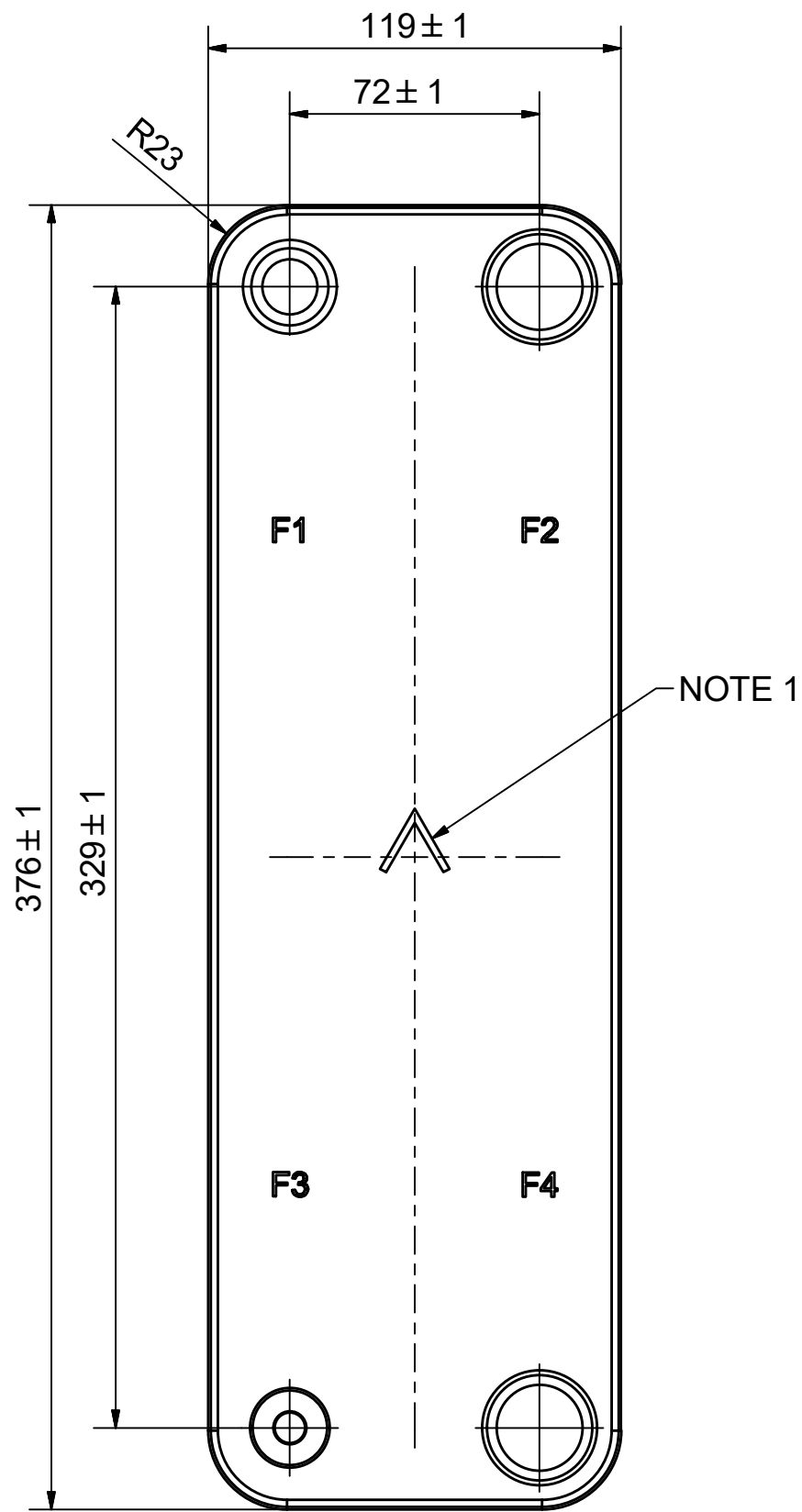

NOTE 1 ALTERNATE MARKING: STICKER OR STAMP

**AXINTRA**  
ÉCHANGEURS THERMIQUES

F4	45050	ISO-G 1" A, TH = 20,1	CD000033
F3	41625	SOLDER $\varnothing 9,65$ , TH = 20,1	CD001229
F2	45050	ISO-G 1" A, TH = 20,1	CD000033
F1	33221	SOLDER 22U, TH = 20,1	CD001017

Pos	Article No	Title / Denomination, code, material, dimension etc	Drawing No./ref	Pos	Article No	Title / Denomination, code, material, dimension etc	Drawing No./ref
-----	------------	---	-----------------	-----	------------	---	-----------------

Title		B26H/1P-SC-M	
 A DOVER COMPANY		Created Date	2019-01-18
		Created By	AU
Article/Configuration number		15094-014	
Drawing number		AU00452465	

REV	ALTERATION	DATE	CHECKED	APPROVED
02	DESIGN CHANGE ACCORDING TO DOC RD101273	2015/12/14	CNVG	PDM

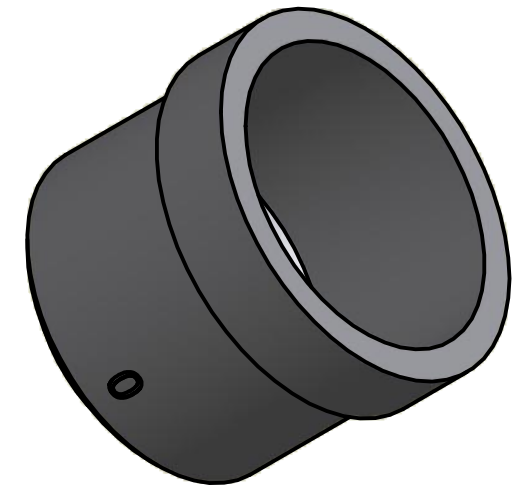
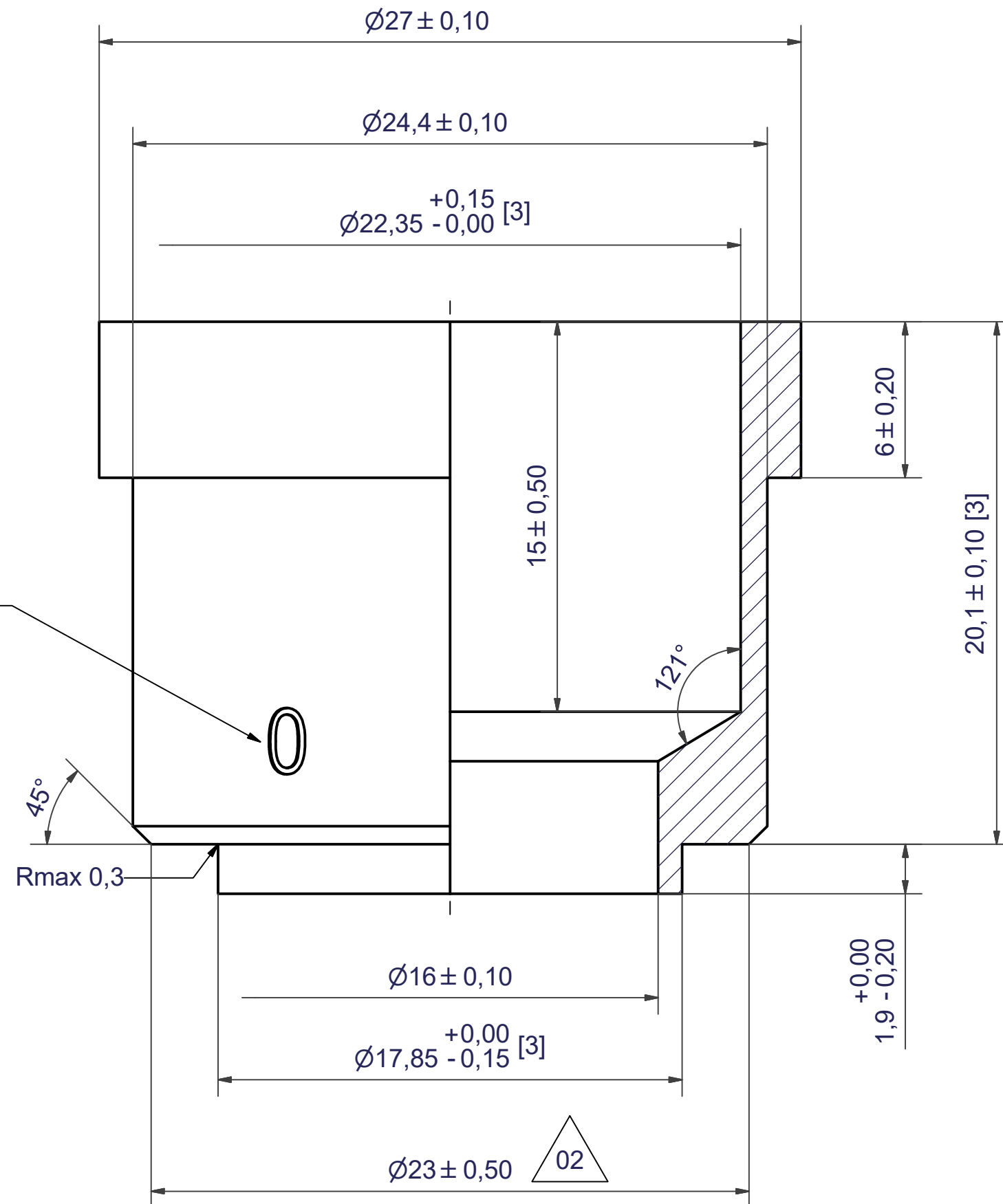

NOTE 1

NOTE 2: [3] - CRITICAL/SPECIAL CHARACTERISTIC TO BE FOLLOWED  
 NOTE 1: MARKING TEXT "0" FOR IDENTIFICATION ONLY  
 PRESENT AT 2 PLACES 180° FROM EACH OTHER  
 0 = 304 MATERIAL

ACCORDING TO MQS  
 MATERIAL

Drawn <i>inrj</i>	Checked <i>PDM</i>	Approved <i>PDM</i>	Created Date 2008-06-27	General geometrical tolerancing ISO 2768 <i>m</i>	General surface finish $R_a$ 3.2	Scale -
			Title <b>SOLDER 22U</b>			
			Article number	Drawing number <b>CD001017</b>	Revision 02	Sheet 1 (1)

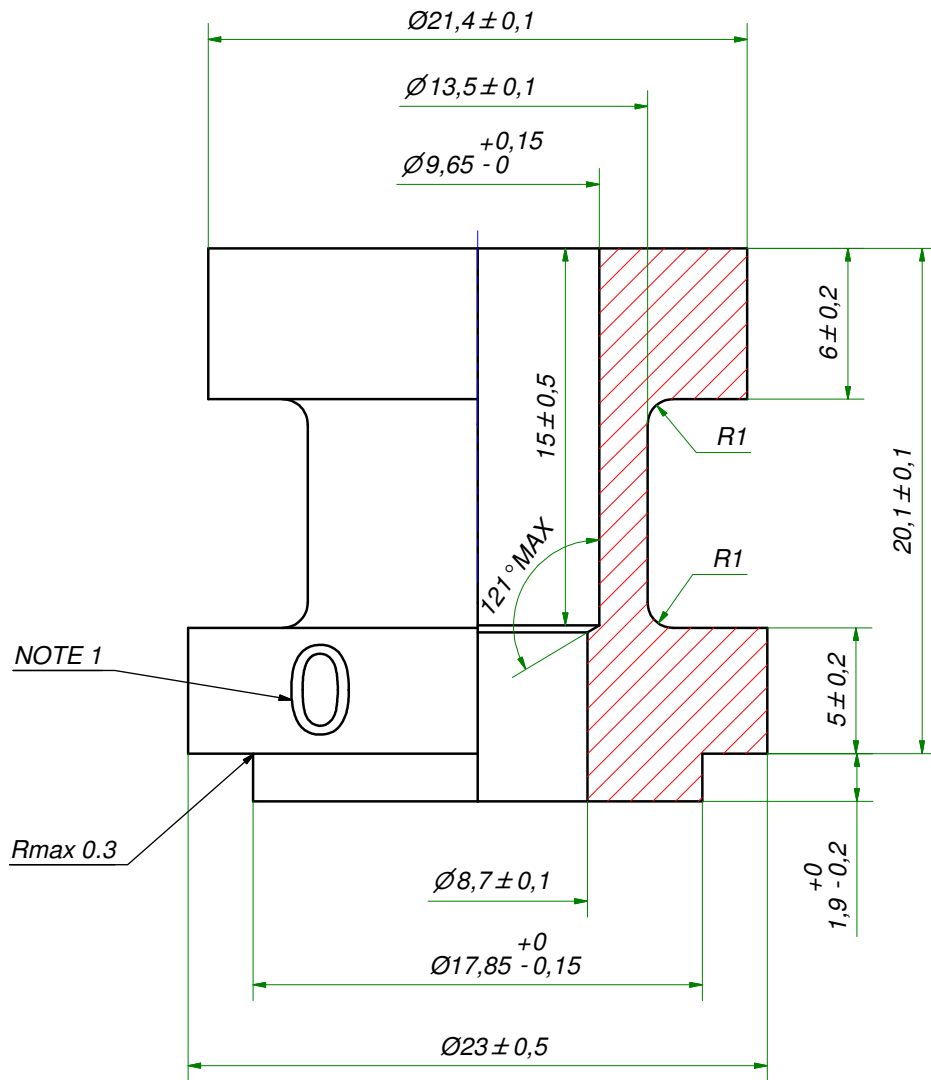

NOTE 1: MARKING TEXT "0" FOR IDENTIFICATION ONLY  
PRESENT AT 2 PLACES 180° FROM EACH OTHER  
"0" = 304 MATERIAL

DEBURR SHARP EDGES; MAX 0.4

ACCORDING TO MQS

Material

Drawn	Checked	Approved	Created Date	General geometrical tolerancing ISO 2768	General surface finish $R_a$	Scale
SKMZP	PDM	PDM	2010-04-28	m	3.2	-
				Title		
				SOLDER $\varnothing 9,65$		
Article number		Drawing number		Revision	Sheet	
-		CD001229		-	1 (1)	

# SWEP MANUFACTURING

Rev No.	Alteration	Date	Checked	Approved
13	CHANGED TOLERANCE OF THREAD	2006/12/11	THE	PDM

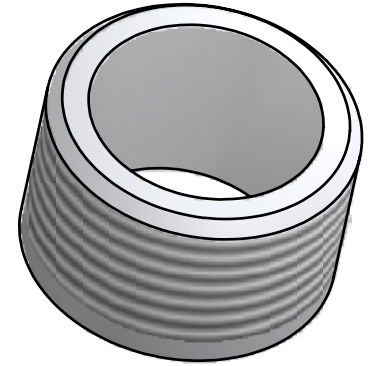
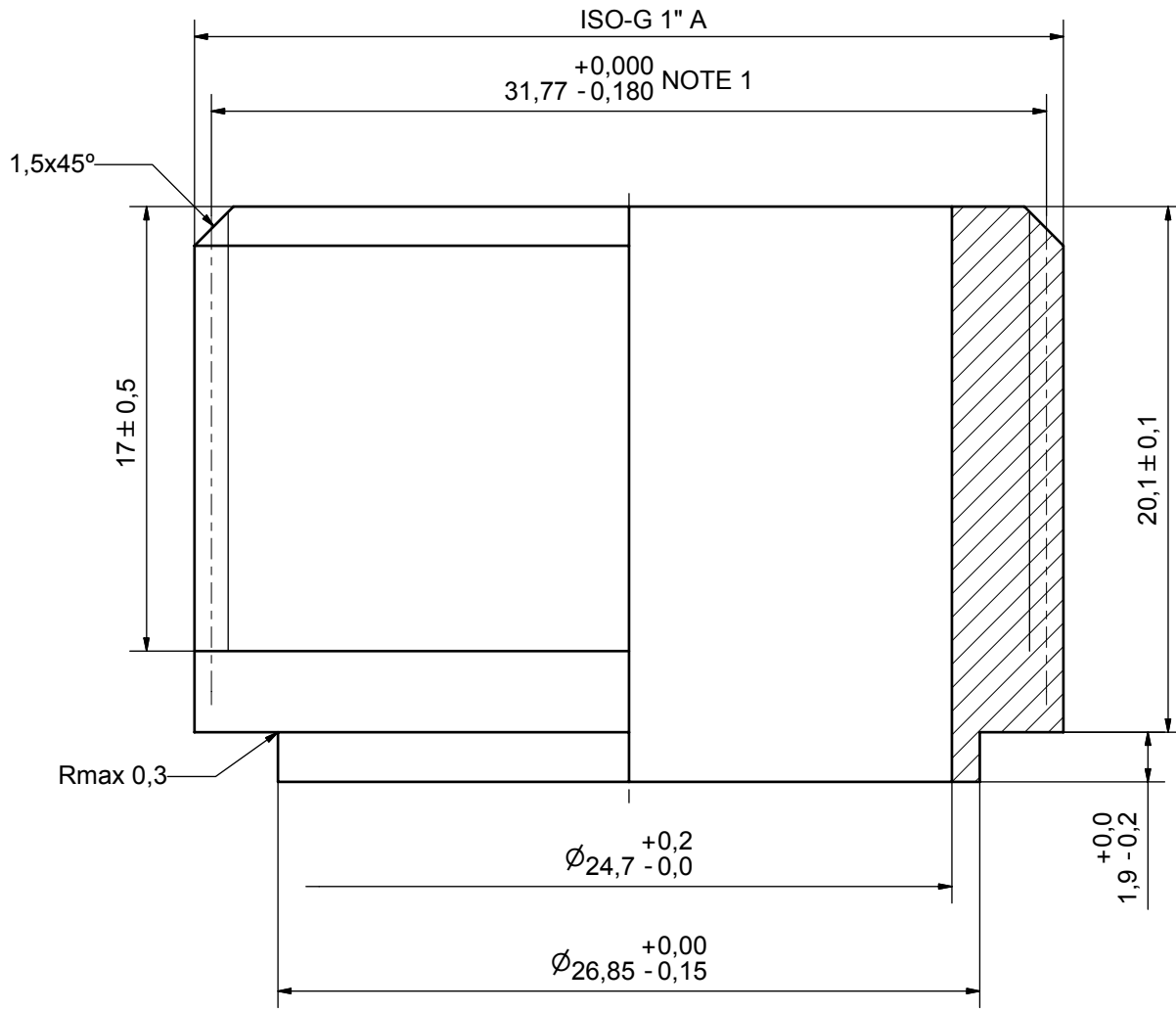

NOTE 1: ADDITIONAL REQUIREMENT ON ISO 228/1 THREAD PERMISSIBLE TOLERANCE ON PITCH DIAMETER

© Company Confidential, Property of SWEP International AB



ACCORDING TO MQS  
MATERIAL

Drawn EG	Checked HR	Approved BOS	Created Date 1990/09/08	General geometrical tolerancing ISO 2768 m	General surface finish $R_a$ 3.2	Scale 5:1
Title <b>SWEP</b>			ISO-G 1" A			
Article number -		Drawing number CD000033		Revision 13	Sheet 1 (2)	

