

B26

Intégrant des canaux AsyMatrix®, le condensateur B26 est conçu pour offrir de hautes performances, qui en font le choix idéal pour les applications de pompes à chaleur. Notre technologie AsyMatrix® combine un échangeur thermique très performant avec de faibles pertes de charge. Elle permet aux fabricants d'obtenir des systèmes à la fois plus compacts et plus efficaces. Grâce à sa haute performance, à son volume interne faible et à son encombrement réduit, ce BPHE occupe une position unique sur le marché en apportant une réponse parfaite aux besoins de nombreuses applications et fonctions.



Spécifications de base

Nombre de plaques max. (NoP)	160
Débit volumétrique max.	11,3 m ³ /h (13.21 gpm)
Volume du canal	0.044/0.066 dm ³ (0.0016/0.0023 ft ³)
Matières	Plaques en acier inoxydable 316, brasage cuivre
Poids sans les connexions	1.49+(0.1076*NoP) kg 3.29+(0.237*NoP) lb

Les dimensions standard

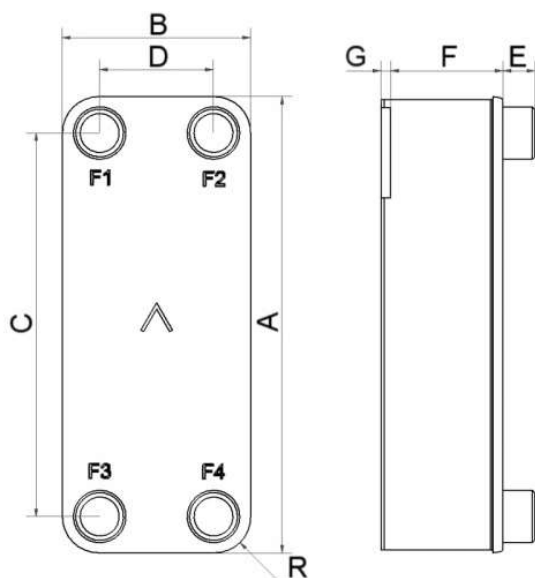

#	MM	IN
A	376	14.8
B	119	4.69
C	329	12.95
D	72	2.83
F	4.00+1.61*(NoP)	0.16+0.06*(NoP)
G	6	0.24
R	23	0.91
E_1	20	0.79

PED pression / température

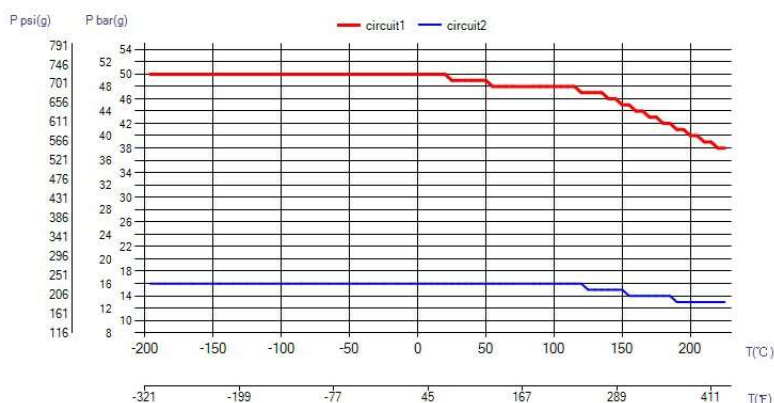

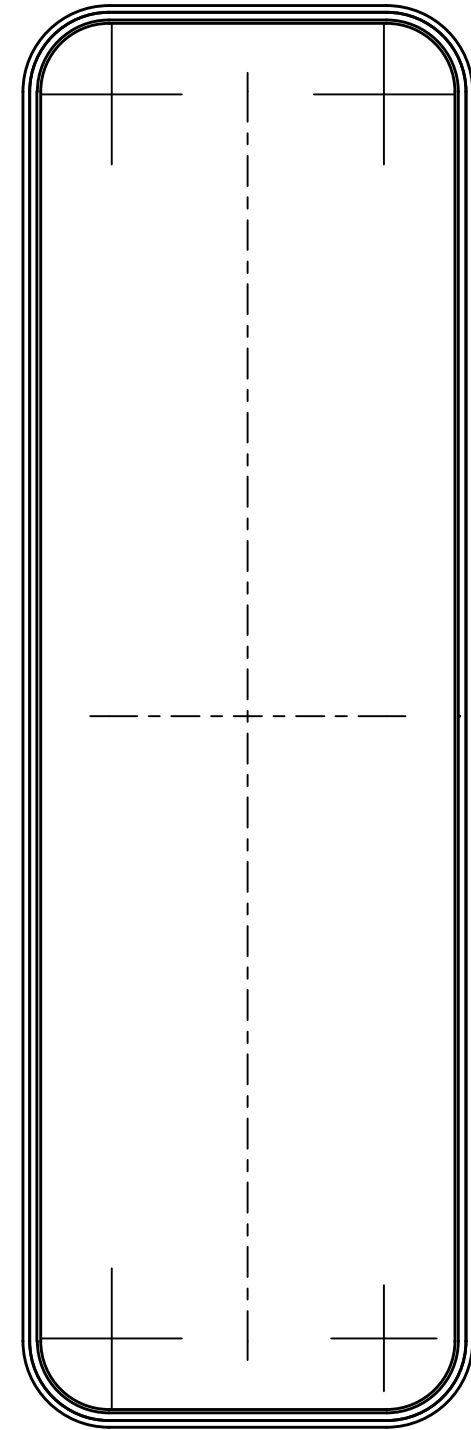
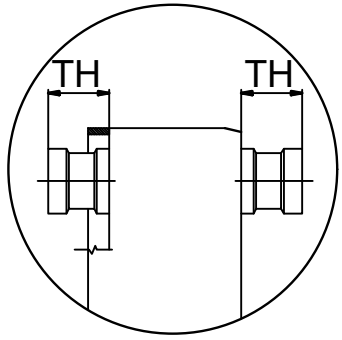
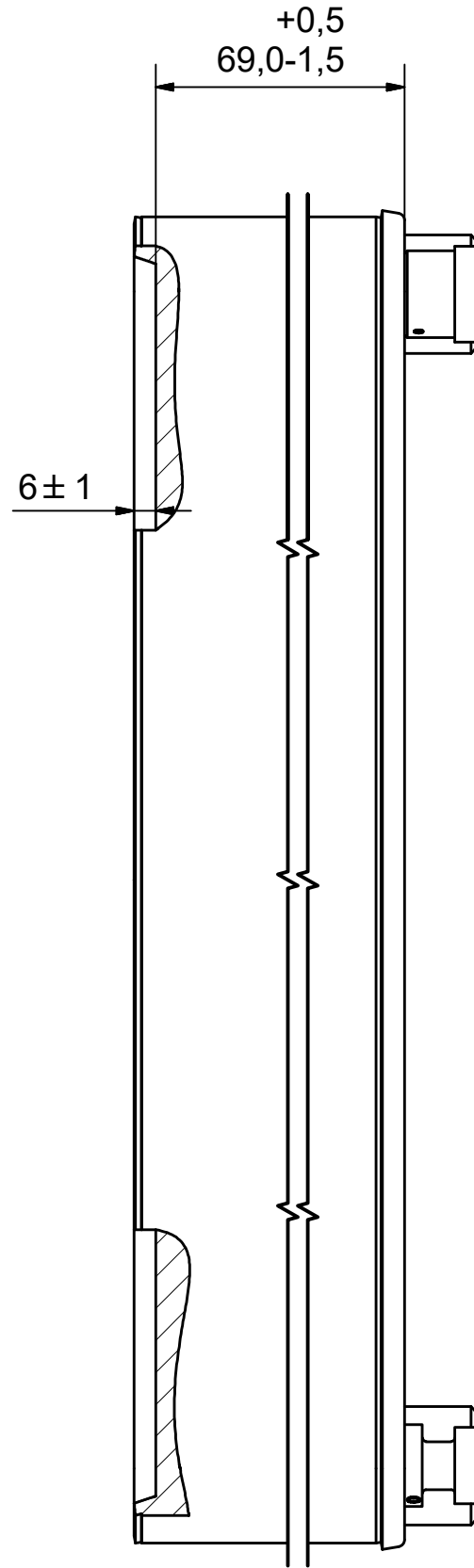
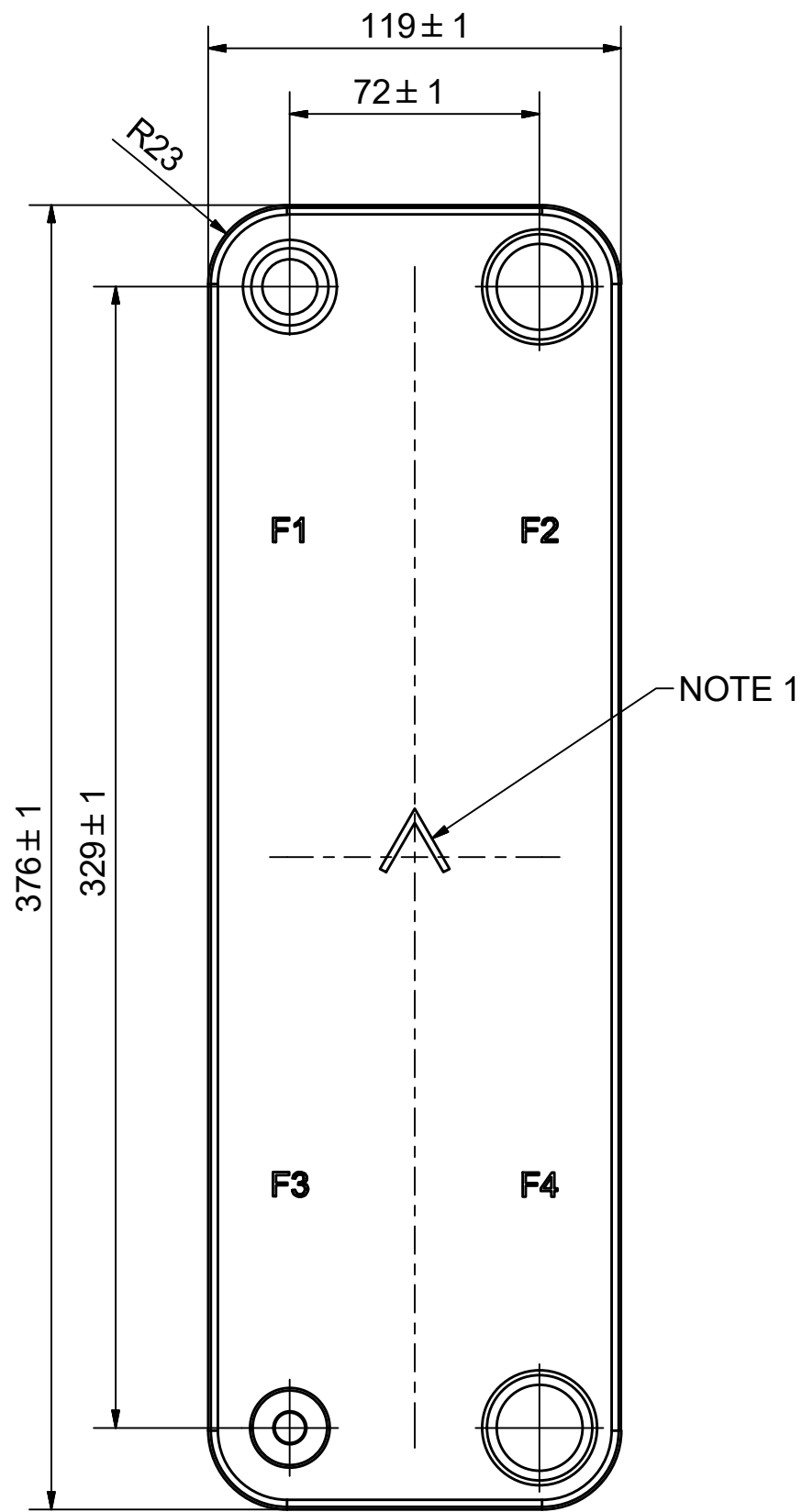

ÉCHANGEURS THERMIQUES



AXINTRA
ÉCHANGEURS THERMIQUES

NOTE 1 ALTERNATE MARKING: STICKER OR STAMP

F4	45050	ISO-G 1" A, TH = 20,1	CD000033
F3	41625	SOLDER $\varnothing 9,65$, TH = 20,1	CD001229
F2	45050	ISO-G 1" A, TH = 20,1	CD000033
F1	33221	SOLDER 22U, TH = 20,1	CD001017

Title		B26H/1P-SC-M	
 A DOVER COMPANY	Created Date	Created By	
	2019-01-18	AU	
	Article/Configuration number	Drawing number	
	15094-040	AU00452466	

Pos	Article No	Title / Denomination, code, material, dimension etc	Drawing No./ref	Pos	Article No	Title / Denomination, code, material, dimension etc	Drawing No./ref
-----	------------	---	-----------------	-----	------------	---	-----------------

REV	ALTERATION	DATE	CHECKED	APPROVED
02	DESIGN CHANGE ACCORDING TO DOC RD101273	2015/12/14	CNVG	PDM

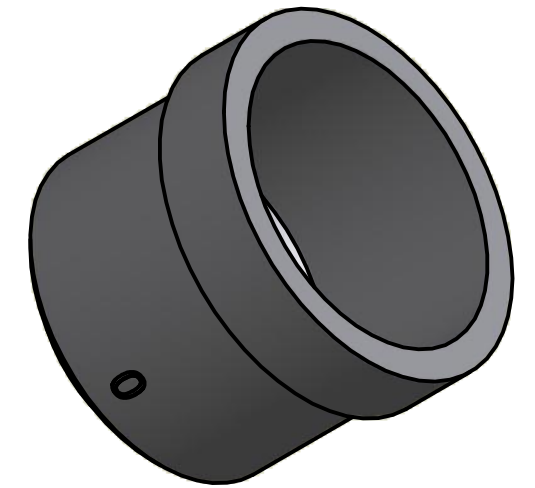
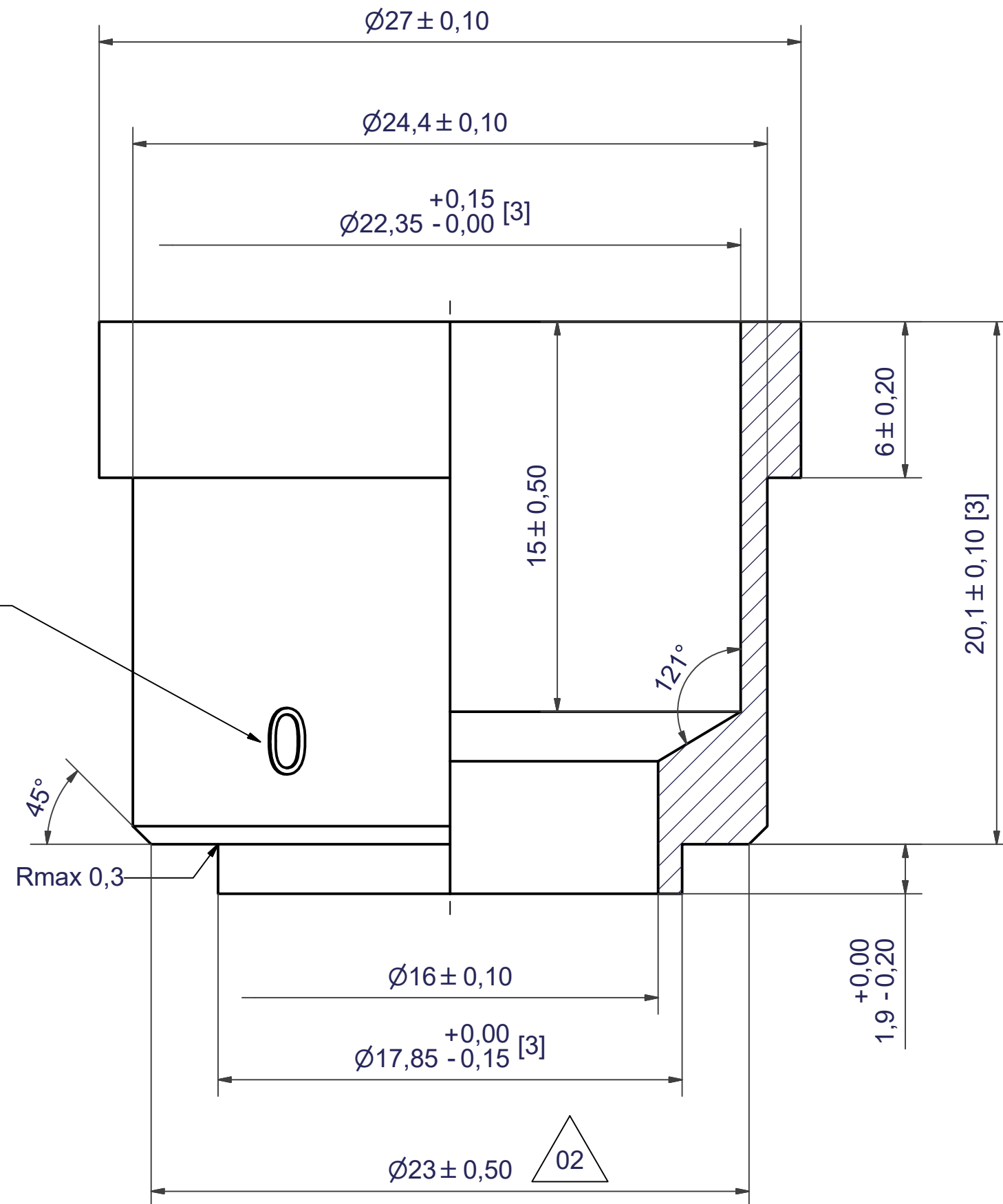

NOTE 1

NOTE 2: [3] - CRITICAL/SPECIAL CHARACTERISTIC TO BE FOLLOWED
 NOTE 1: MARKING TEXT "0" FOR IDENTIFICATION ONLY
 PRESENT AT 2 PLACES 180° FROM EACH OTHER
 0 = 304 MATERIAL

ACCORDING TO MQS
 MATERIAL

Drawn <i>inrj</i>	Checked <i>PDM</i>	Approved <i>PDM</i>	Created Date 2008-06-27	General geometrical tolerancing ISO 2768 <i>m</i>	General surface finish R_a 3.2	Scale -
			Title SOLDER 22U			
A DOVER COMPANY			Article number	Drawing number CD001017	Revision 02	Sheet 1 (1)

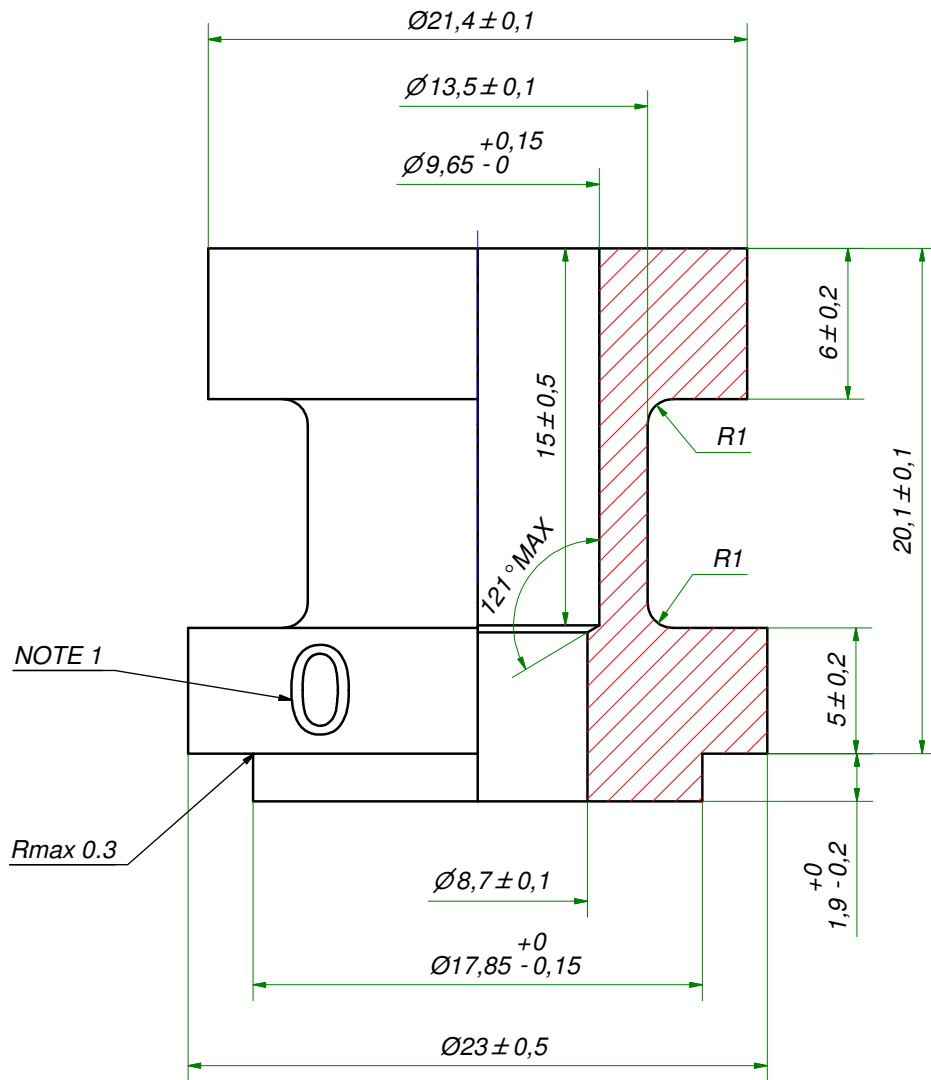

NOTE 1: MARKING TEXT "0" FOR IDENTIFICATION ONLY
PRESENT AT 2 PLACES 180° FROM EACH OTHER
"0" = 304 MATERIAL

DEBURR SHARP EDGES; MAX 0.4

ACCORDING TO MQS

Material

Drawn	Checked	Approved	Created Date	General geometrical tolerancing ISO 2768	General surface finish R_a	Scale
SKMZP	PDM	PDM	2010-04-28	m	3.2	-
				Title		
				SOLDER $\varnothing 9,65$		
Article number		Drawing number		Revision	Sheet	
-		CD001229		-	1 (1)	

SWEP MANUFACTURING

Rev No.	Alteration	Date	Checked	Approved
13	CHANGED TOLERANCE OF THREAD	2006/12/11	THE	PDM

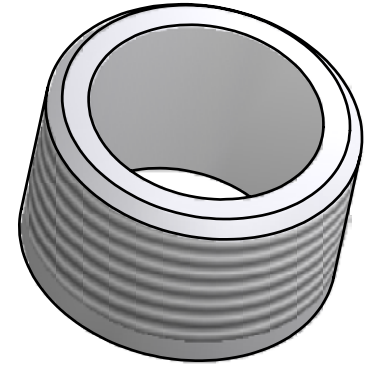
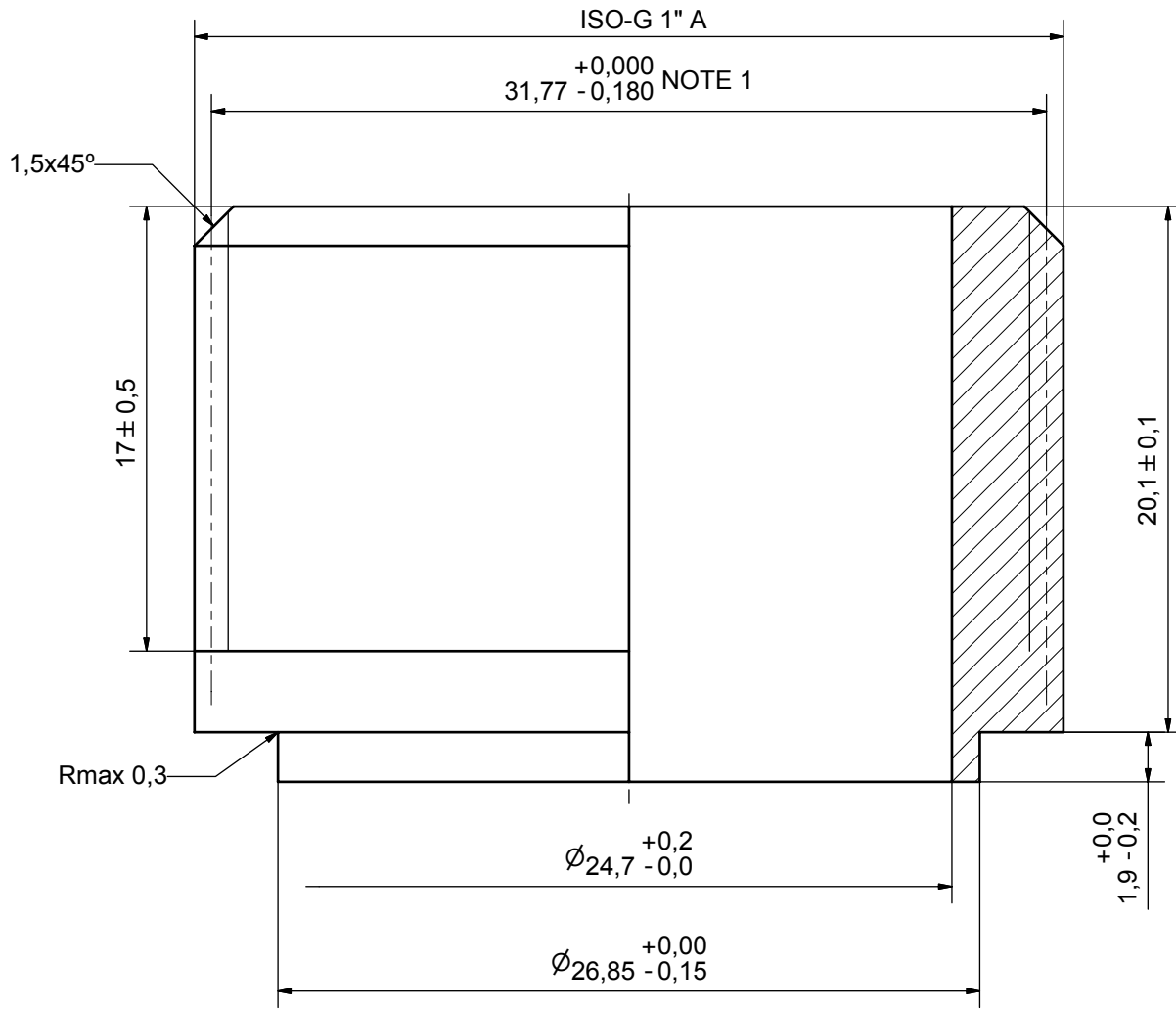

NOTE 1: ADDITIONAL REQUIREMENT ON ISO 228/1 THREAD PERMISSIBLE TOLERANCE ON PITCH DIAMETER

© Company Confidential, Property of SWEP International AB



ACCORDING TO MQS
MATERIAL

Drawn EG	Checked HR	Approved BOS	Created Date 1990/09/08	General geometrical tolerancing ISO 2768 m	General surface finish R_a 3.2	Scale 5:1
			Title ISO-G 1" A			
Article number -			Drawing number CD000033		Revision 13	Sheet 1 (2)

A DOVER COMPANY