

B12

Avec ses larges ports, le B12 apporte des solutions de transfert thermique adaptées aux débits importants. Il est disponible avec différents agencements de plaques pour répondre aux besoins d'une gamme étendue de viscosités et densités des fluides. Le B12 est un excellent choix pour les applications exigeantes comme la vapeur et les dessiccateurs d'air. Il peut servir de désurchauffeur dans un système de climatisation et de CO2 sous refroidisseur gaz pour système de réfrigération.



Spécifications de base

Nombre de plaques max. (NoP)	140
Débit volumétrique max.	16,9 m³/h (39.63 gpm)
Volume du canal	0.063/0.063 dm³ (0.0022/0.0022 ft³)
Matières	Plaques en acier inoxydable 316, brasage cuivre
Poids sans les connexions	1.12+(0.12*NoP) kg 2.47+(0.265*NoP) lb

Les dimensions standard

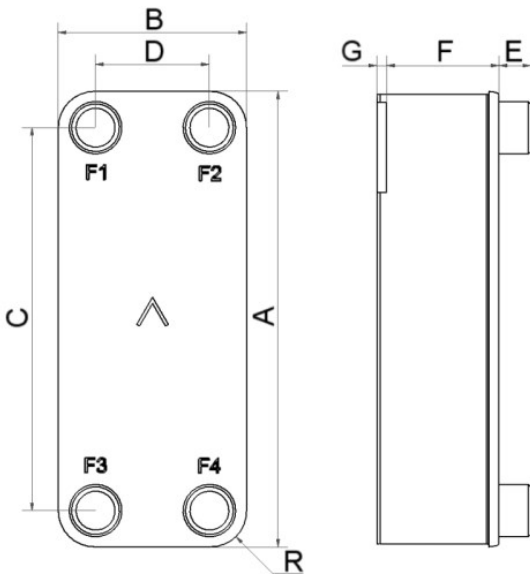

#	MM	IN
A	287	11.3
B	117	4.61
C	234	9.21
D	63	2.48
F	4.40+2.34*(NoP)	0.17+0.09*(NoP)
G	6	0.24
R	22	0.87
E_1	27	1.06

PED pression / température

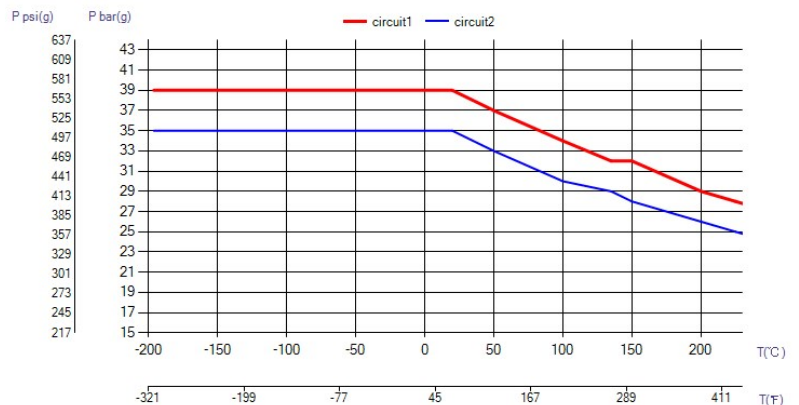

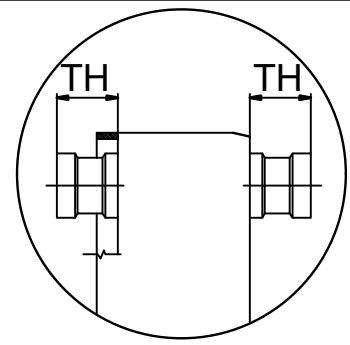
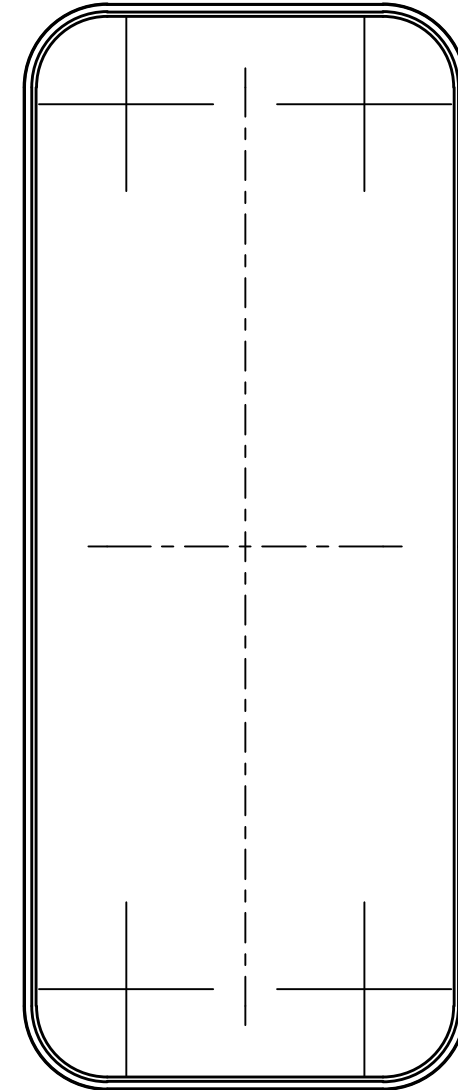
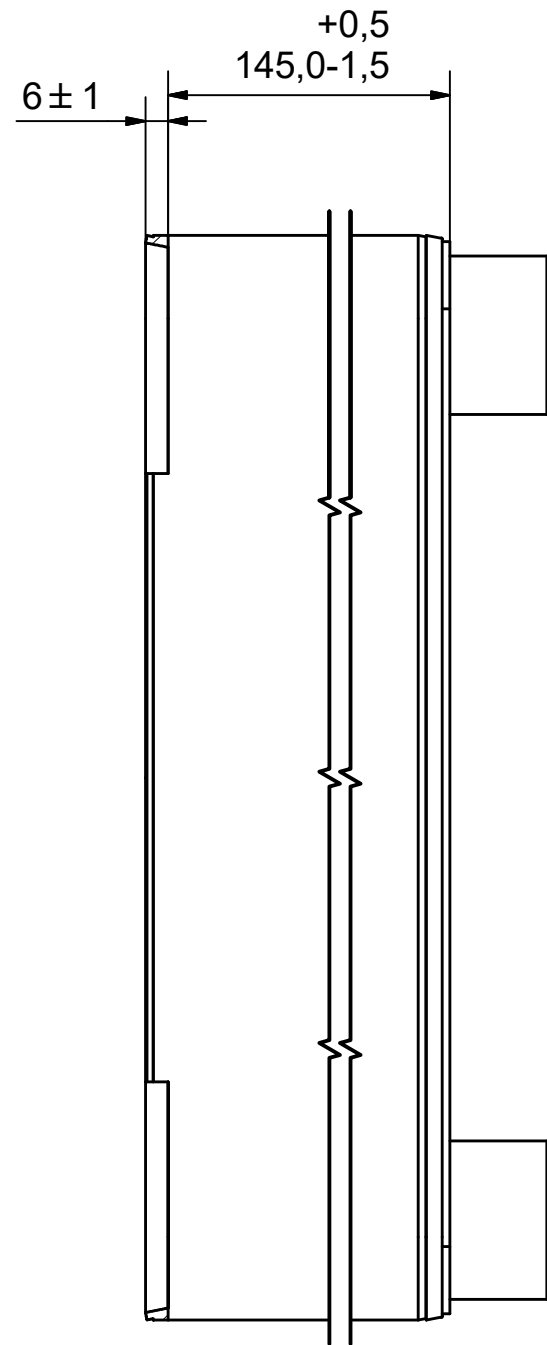
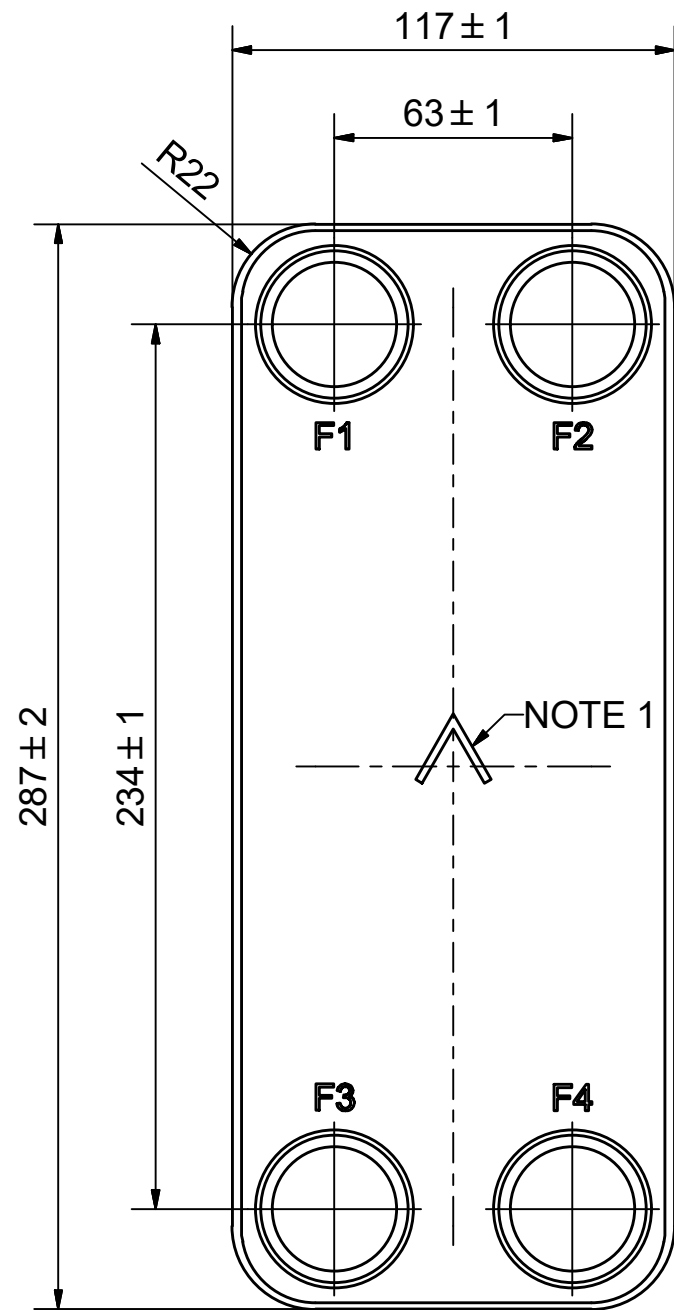

NOTE 1 ALTERNATE MARKING: STICKER OR STAMP

F4	45609	ISO-G 1 1/4" A, TH = 27.1	CD000193
F3	45609	ISO-G 1 1/4" A, TH = 27.1	CD000193
F2	45609	ISO-G 1 1/4" A, TH = 27.1	CD000193
F1	45609	ISO-G 1 1/4" A, TH = 27.1	CD000193

Pos	Article No	Title / Denomination, code, material, dimension etc	Drawing No./ref	Pos	Article No	Title / Denomination, code, material, dimension etc	Drawing No./ref
-----	------------	---	-----------------	-----	------------	---	-----------------



Title		B12L/1P-SC-S	
Created Date		7/17/2020	Created By
Article/Configuration number		11014-060	Drawing number
A DOVER COMPANY		AU00585011	

SWEP MANUFACTURING

Rev No	Alteration	Date	Checked	Approved
06	CHANGED DESIGN ACCORDING TO RD100699	2013-04-12	SKZE	miguser

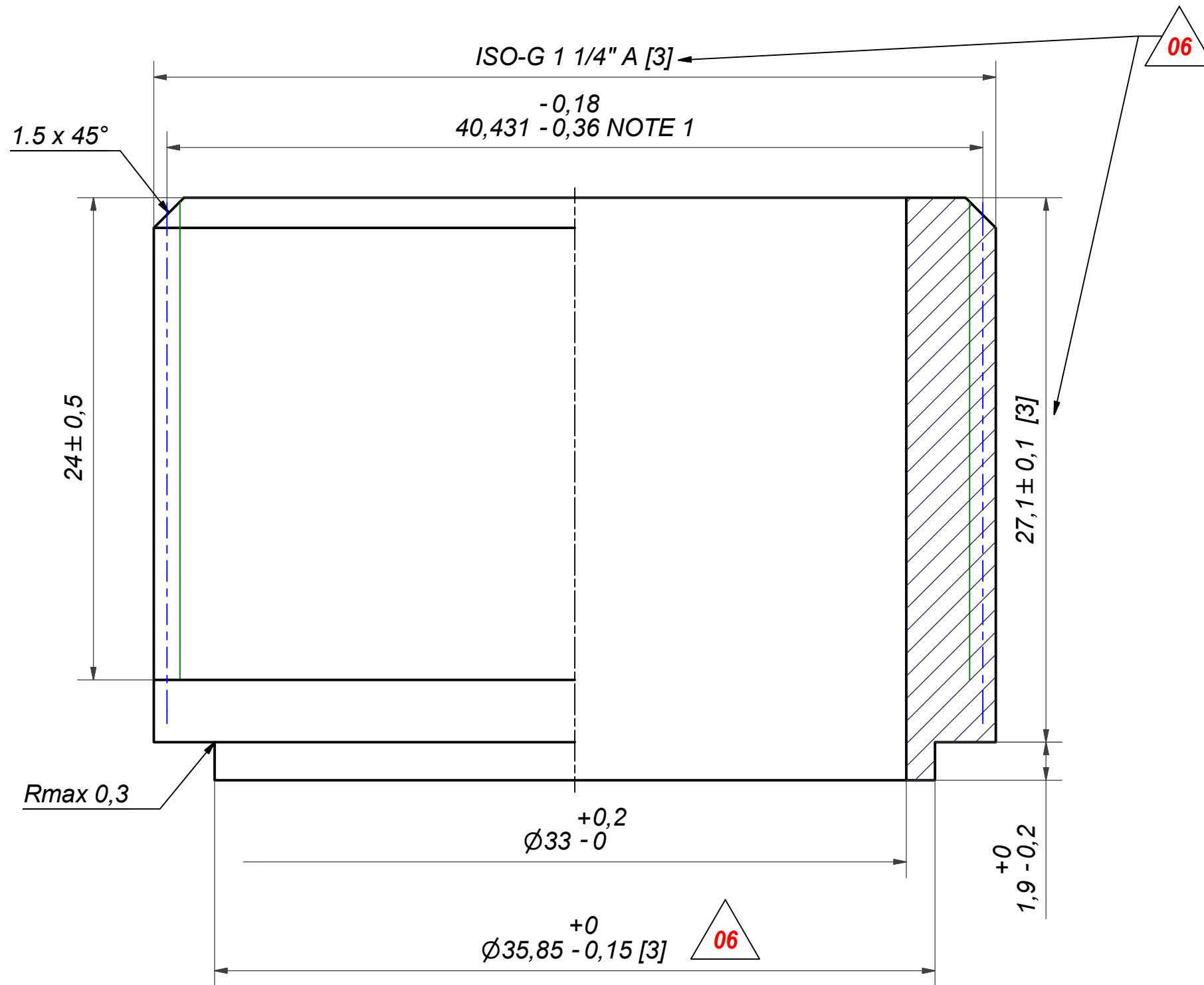

NOTE 1: ADDITIONAL REQUIREMENT ON ISO 228/1 THREAD
 PERMISSIBLE TOLERANCE ON PITCH DIAMETER
 NOTE 2: DEBURR SHARP EDGES: MAX 0,4

ACCORDING TO MQS
 MATERIAL

Drawn	Checked	Approved	Created Date	General geometrical tolerancing ISO 2768:	General surface finish R_a :	Scale	Paper size	
miguser	miguser	miguser	1994-11-18	m	3.2	-	A3	
			Title					
			ISO-G 1 1/4" A					
		Article / Tool number	Design Type	Drawing number	Revision	Sheet		
		CD	CD000193	06	1 (2)			

