

B18

Avec des exigences de pression adaptées aux applications CO2 transcritiques CO2 qui atteignent 140 bars, le B18 est un choix qui s'impose naturellement. Le B18 est optimal pour les pompes à chaleur à haute capacité (jusqu'à 150 kW comme refroidisseur de gaz et jusqu'à 60 kW comme évaporateur). Compact et léger, le B18 est un excellent choix pour les applications de chaîne du froid (supermarchés, transports frigorifiques, récupérateurs de chaleur, économiseurs) et les pompes à chaleur (évaporateur et refroidisseur de gaz).



Spécifications de base

Nombre de plaques max. (NoP)	140
Débit volumétrique max.	9 m ³ /h (39.63 gpm)
Volume du canal	0.061/0.061 dm ³ (0.0022/0.0022 ft ³)
Matières	Plaques en acier inoxydable 316, brasage cuivre
Poids sans les connexions	4.05+(0.2504*NoP) kg 8.92+(0.552*NoP) lb

Les dimensions standard

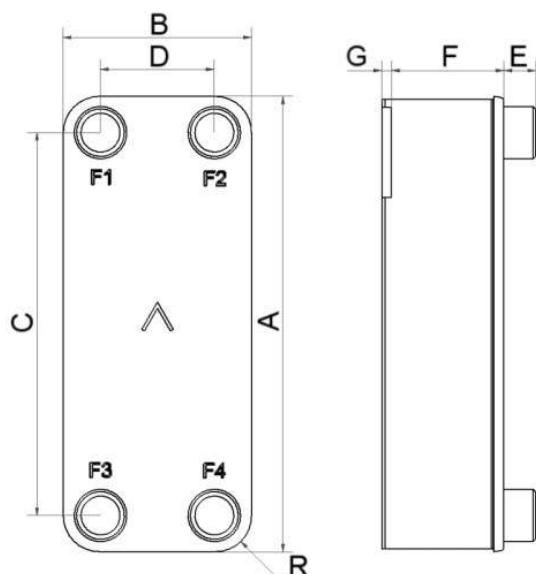

#	MM	IN
A	377	14.84
B	119.50	4.7
C	329	12.95
D	72	2.83
F	12.00+2.00*(NoP)	0.47+0.08*(NoP)
G	2	0.08
R	23.50	0.93
E_1	45	1.77

PED pression / température

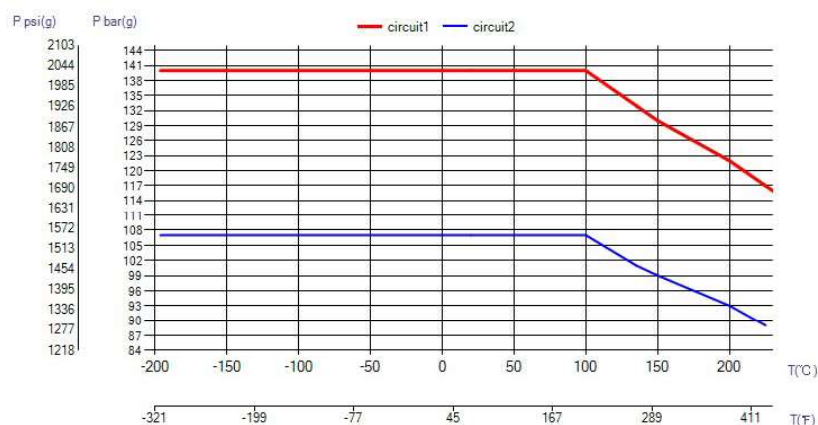

ÉCHANGEURS THERMIQUES

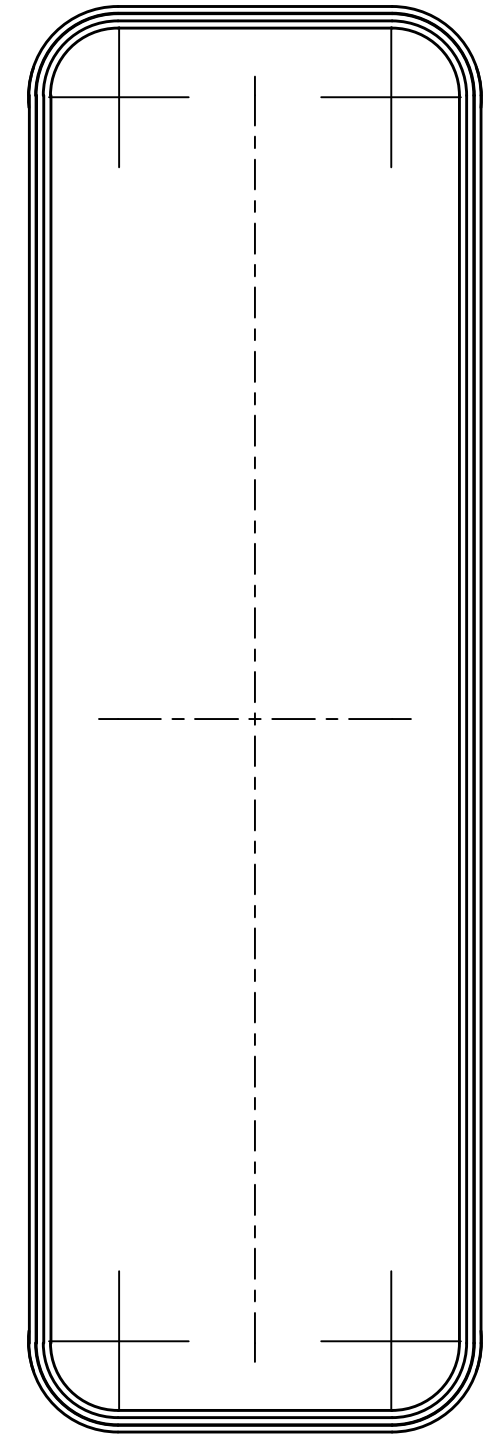
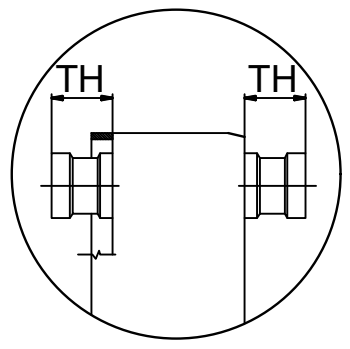
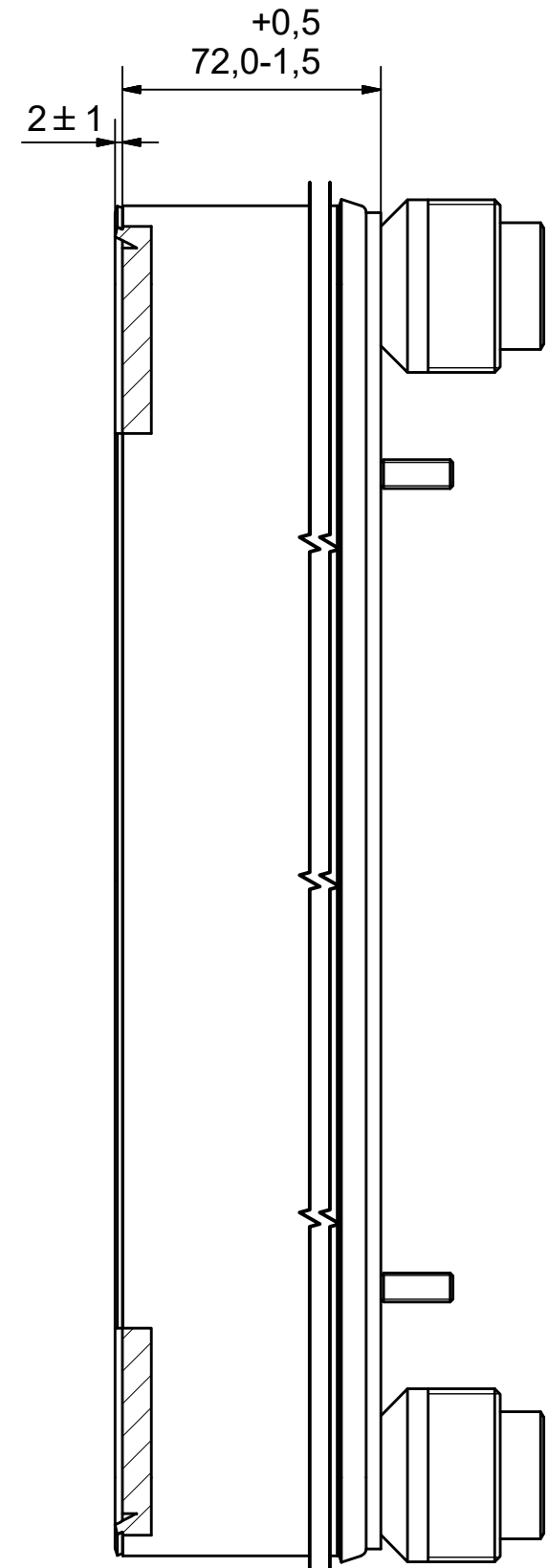
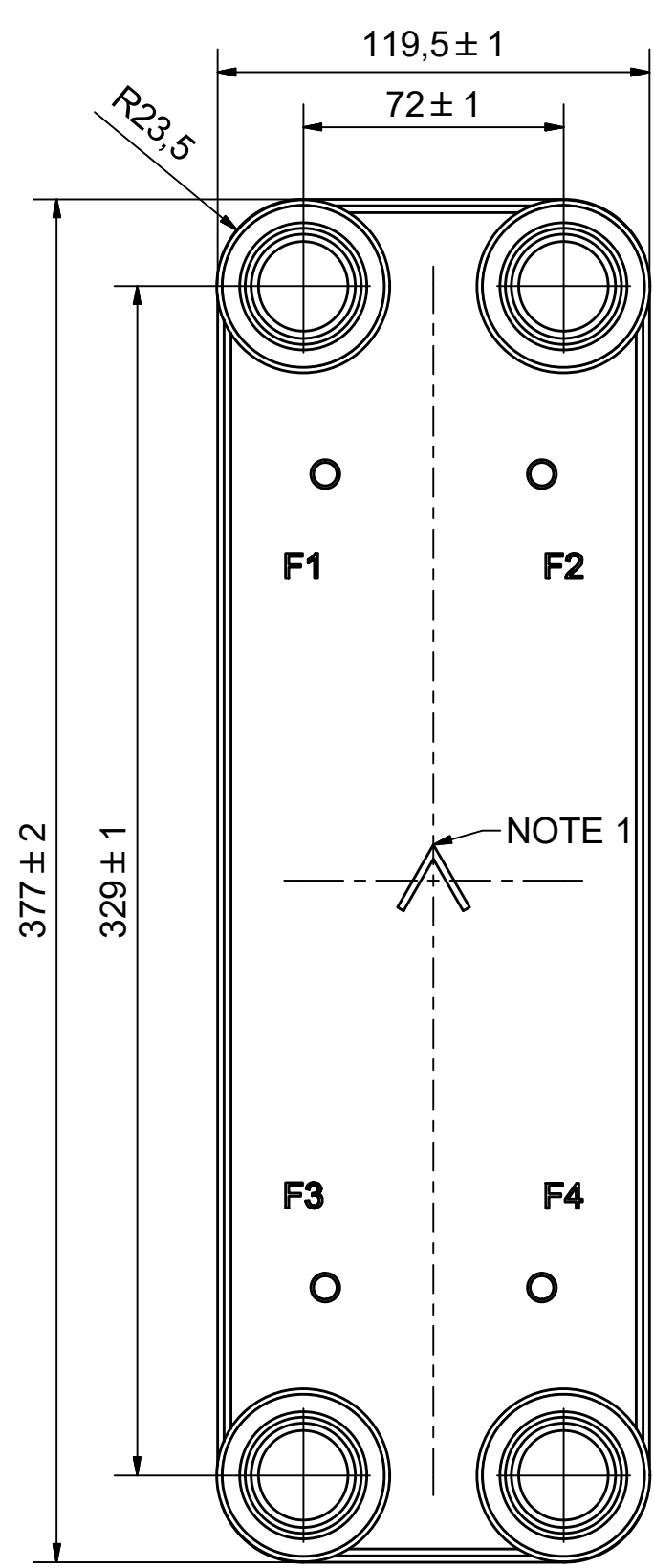



AXINTRA
ÉCHANGEURS THERMIQUES

NOTE 1 ALTERNATE MARKING: STICKER OR STAMP

F4	37192	ISO-G 1 1/2" A, WELD 35.1 & SOLDER	CD001651
F3	37192	ISO-G 1 1/2" A, WELD 35.1 & SOLDER	CD001651
F2	37192	ISO-G 1 1/2" A, WELD 35.1 & SOLDER	CD001651
F1	37192	ISO-G 1 1/2" A, WELD 35.1 & SOLDER	CD001651
F	21422	B18DW S B LOC F 4xC225x60	CG161001_1

Pos	Article No	Title / Denomination, code, material, dimension etc	Drawing No./ref	Pos	Article No	Title / Denomination, code, material, dimension etc	Drawing No./ref
-----	------------	---	-----------------	-----	------------	---	-----------------

Title		B18H/1P-SC-U	
 A DOVER COMPANY	Created Date	Created By	
	2019-07-30	AU	
Article/Configuration number		Drawing number	
15998-030		AU00513749	

Rev No.	Alteration	Date	Checked	Approved
02	CORRECTED PARTS LIST	2005/03/04	ANO	PDM

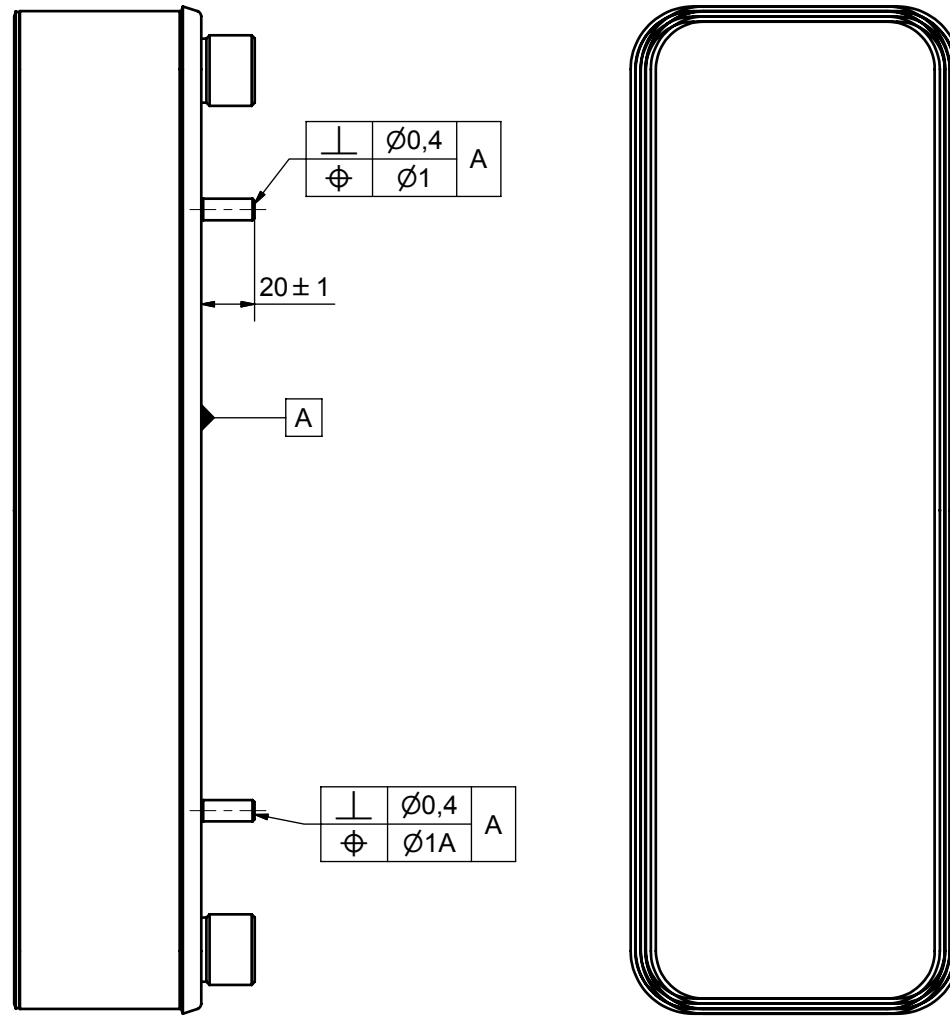
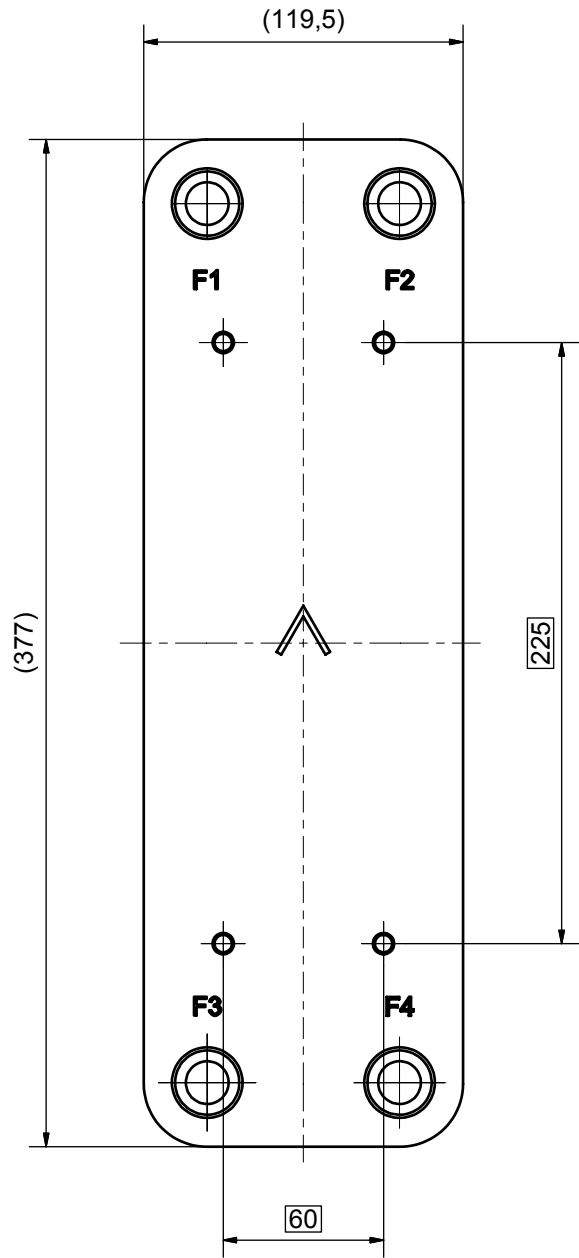

© Company Confidential, Property of SWEP International AB

1	4	STUD BOLT M8x20 ART.NO 45162				M8x20
ITE	QTY	DESCRIPTION				Drawing No.
Drawn	Checked	Approved	Created Date	General geometrical tolerancing ISO 2768	General surface finish R_a	Scale
ANO	PDM	PDM	2005-02-14	m	3.2	1:2
		Title		B16W STUD B LOC F 4xC225x60		
		Article number	Drawing number	Revision	Sheet	
		21422	CG161001	02	1 (1)	

Rev No	Alteration	Date	Checked	Approved
02	DESIGN CHANGE ACC. RD101257	2015-10-08	SKMTB	PDM

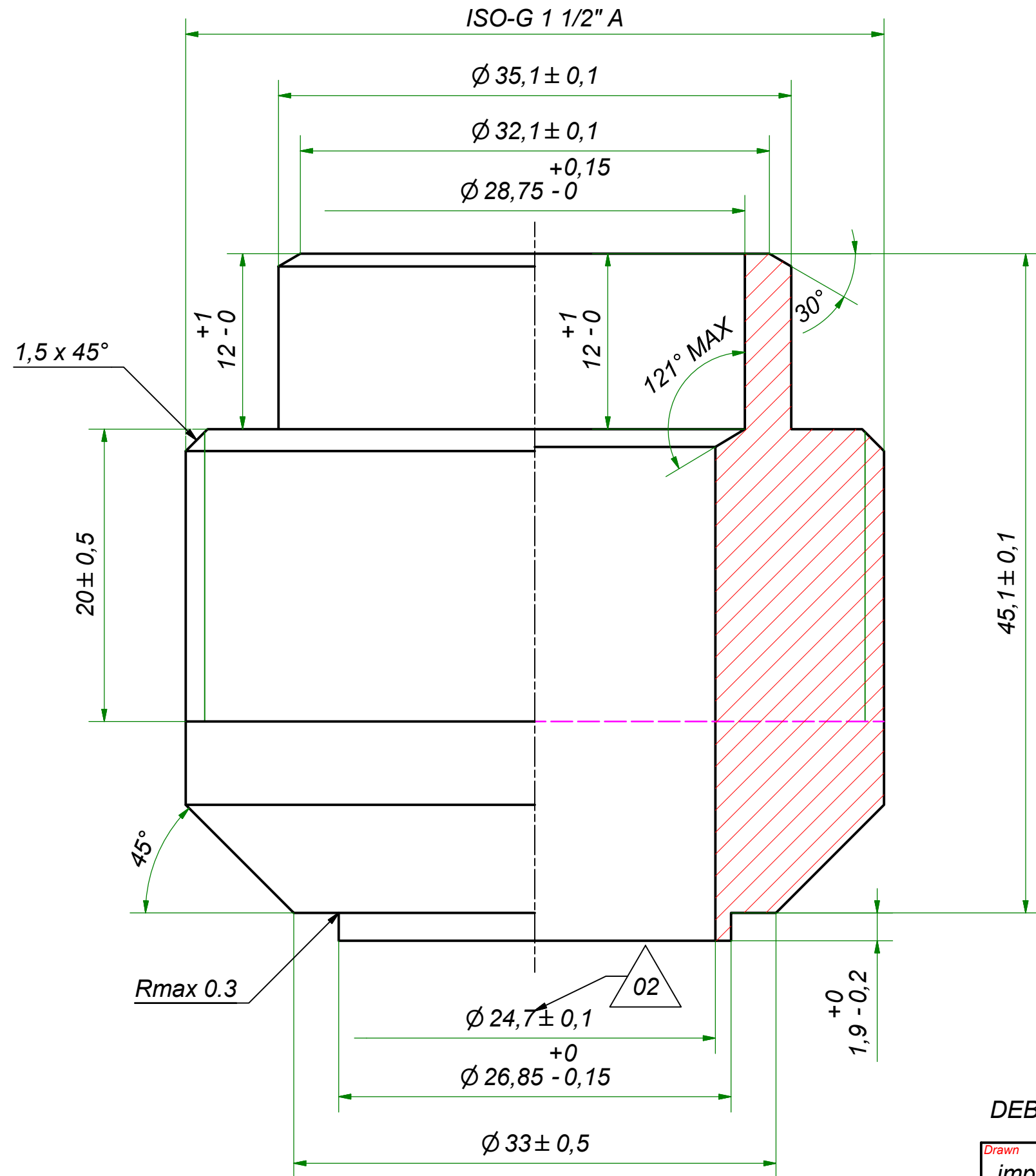

DEBURR SHARP EDGES; MAX 0.4

ACCORDING TO MQS
MATERIAL

Drawn	Checked	Approved	Created Date	General geometrical tolerancing ISO 2768:	General surface finish R_a :	Scale	Paper size
import	PDM	PDM	2012-11-22	m	3.2	-	A3
			ISO-G 1 1/2" A , WELD 35.1 & SOLDER 28.58				
			Article / Tool number	Design Type	Drawing number	Revision	Sheet
			CD	CD001651	02	1 (1)	