

B35T

Le B35T est le produit idéal pour de nombreuses applications : chauffage urbain, récupération de chaleur, cogénération, refroidissement d'huile de transmission et de moteur. Il est le choix parfait pour bénéficier de transferts de chaleur efficaces et de faibles pertes de charges dans des systèmes de conduites jusqu'à 2 pouces et des débits d'eau jusqu'à 27 m³/h (118.8 gpm).



Spécifications de base

Nombre de plaques max. (NoP)	260
Débit volumétrique max.	27 m ³ /h (118.88 gpm)
Volume du canal	0.18/0.18 dm ³ (0.0064/0.0064 ft ³)
Matières	Plaques en acier inoxydable 316, brasage cuivre
Poids sans les connexions	15.76+(0.256*NoP) kg 34.73+(0.564*NoP) lb

Les dimensions standard

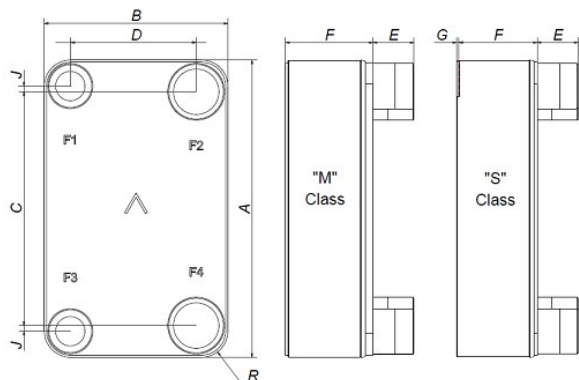

#	MM	IN
A	393	15.47
B	243	9.57
C	324	12.76
D	174	6.85
F	22.00+2.26*(NoP)	0.87+0.09*(NoP)
G	0	0
R	35	1.38
E_1	27	1.06

PED pression / température

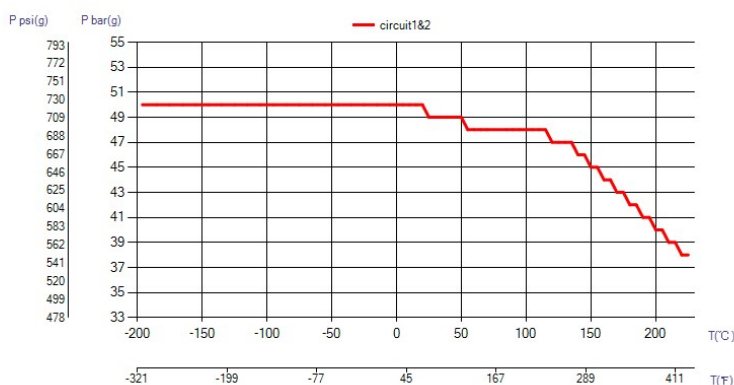

ÉCHANGEURS THERMIQUES

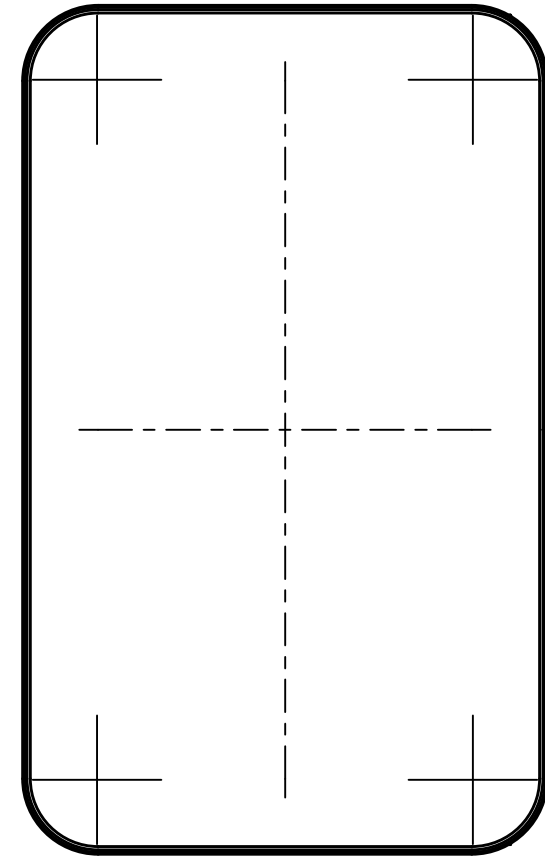
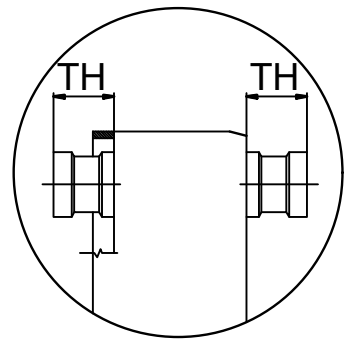
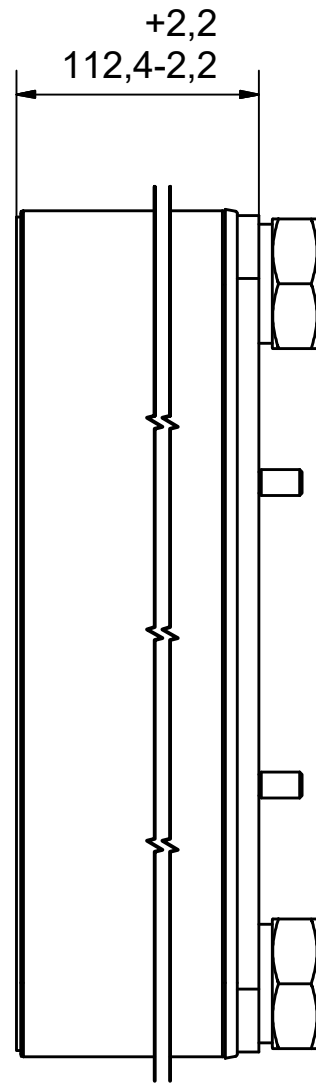
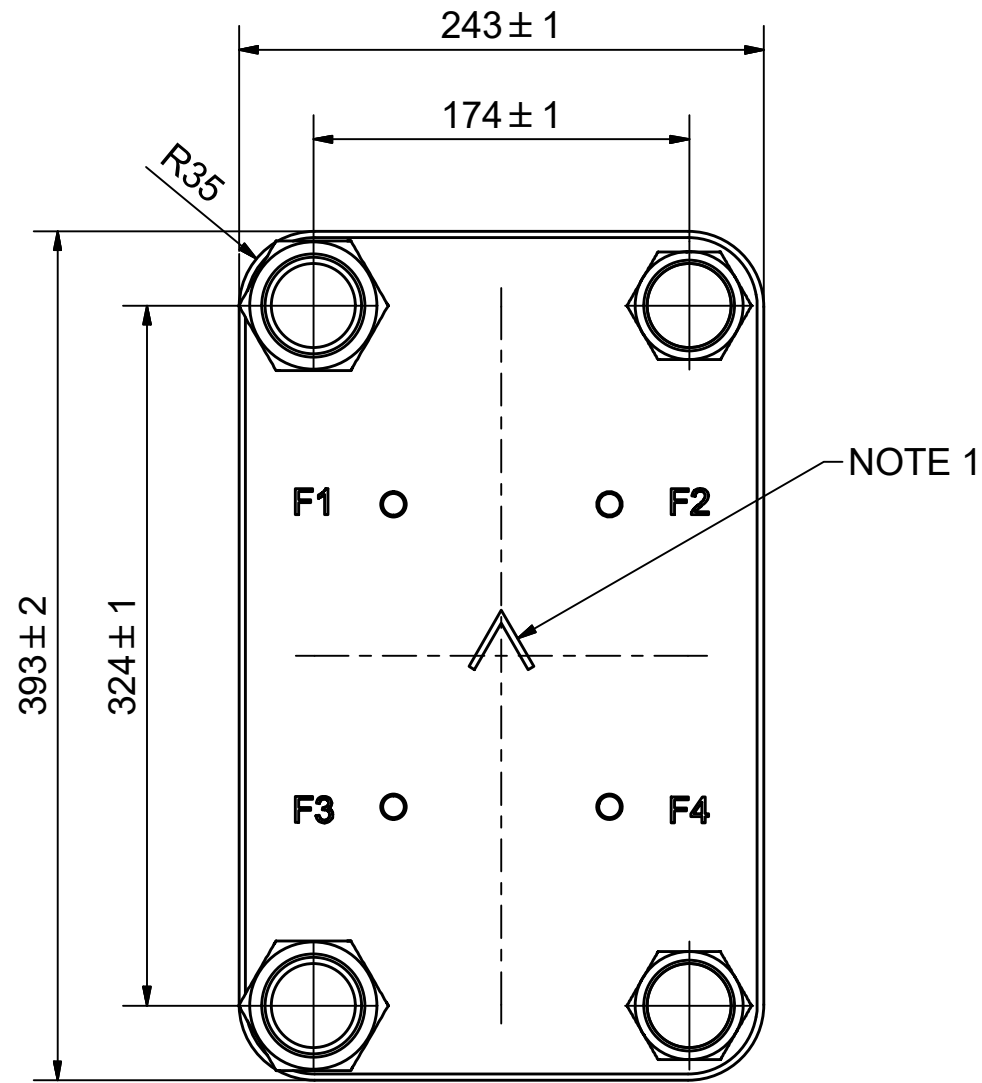

AXINTRA
ÉCHANGEURS THERMIQUES

NOTE 1 ALTERNATE MARKING: STICKER OR STAMP

F4	45427	ISO-G 1 1/4" INT HEX, TH = 27,1	CD000008
F3	45405	ISO-G 1 1/2" INT HEX, TH = 27,1	CD000003
F2	45427	ISO-G 1 1/4" INT HEX, TH = 27,1	CD000008
F1	45405	ISO-G 1 1/2" INT HEX, TH = 27,1	CD000003
F	21112	B35 BOLT LOC F 4x C140x100	CG350001_1

Pos	Article No	Title / Denomination, code, material, dimension etc	Drawing No./ref	Pos	Article No	Title / Denomination, code, material, dimension etc	Drawing No./ref
-----	------------	---	-----------------	-----	------------	---	-----------------

Title B35TM0x40/1P-SC-M 2x1 1/2"INT HEX+2x1 1/4"INT HEX			
 A DOVER COMPANY		Created Date 2024-02-01	Created By AU
		Article/Configuration number 0203360.0	Drawing number AU00032823_0203360.0

Rev No.	Alteration	Date	Checked	Approved
2	REDRAWN IN INVENTOR	2004/12/10	PDM	PDM

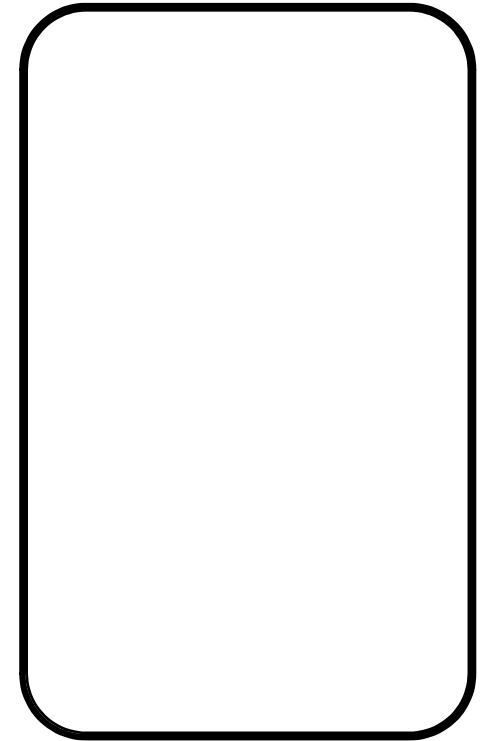
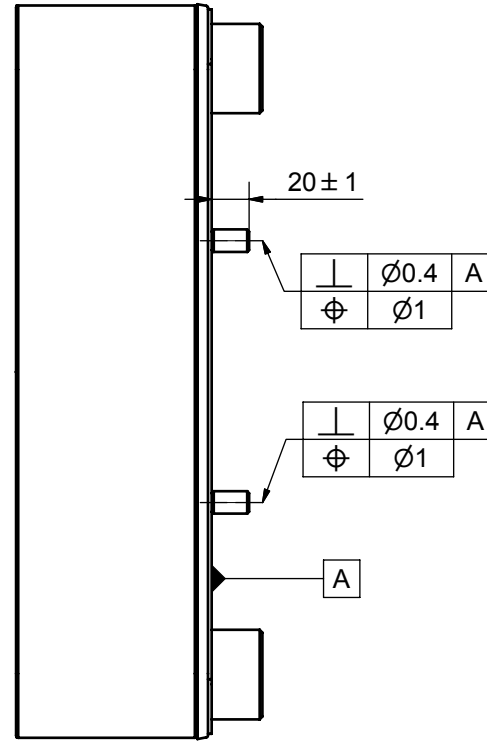
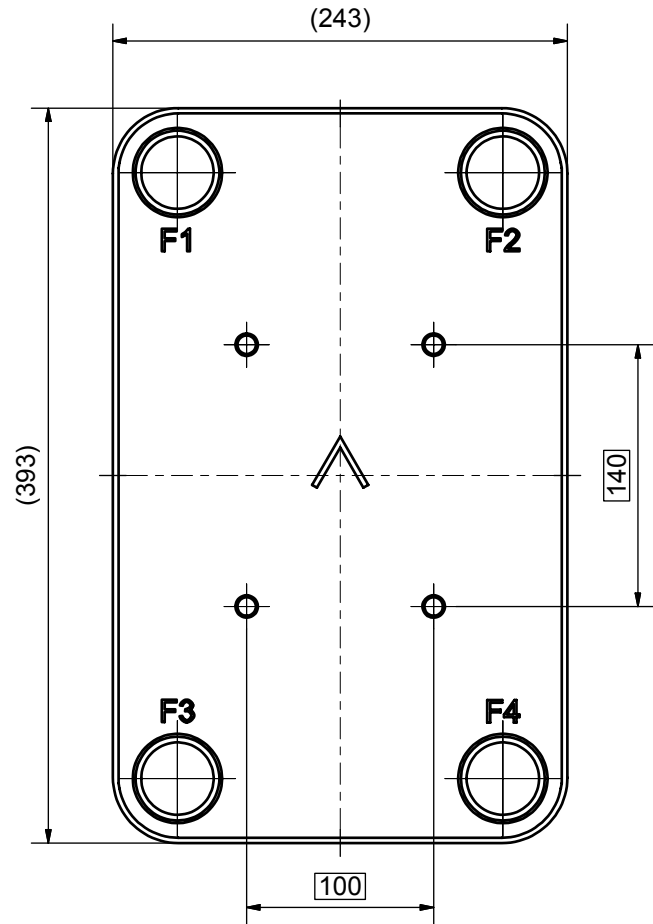

© Company Confidential, Property of SWEP International AB



1	4	STUD BOLT M12 x 20, ART. NO. 45095	M12 x 20
ITE	QTY	DESCRIPTION	Drawing No.
Drawn	Checked	Approved	Created Date
JA	PDM	PDM	2004/10/12
General geometrical tolerancing ISO 2768		General surface finish R_a	
m		3.2	
Title			Scale
B35 BOLT LOC F 4x C140x100			1:1
Article number		Drawing number	Revision
21112		CG350001	2
Sheet			1 (1)



Rev No.	Alteration	Date	Checked	Approved
9	ADDED DEBURR AND MATERIAL INFO	2009/07/28	RJ	PDM

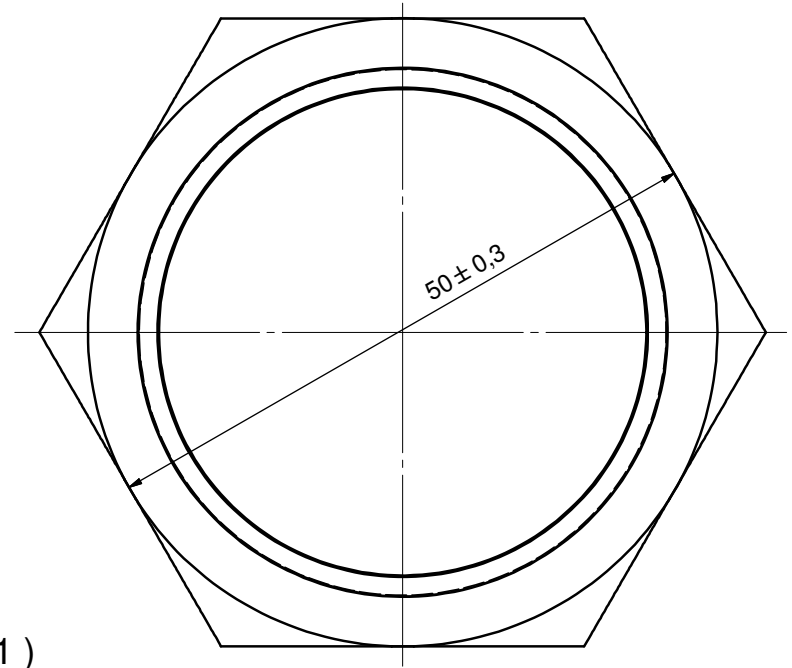
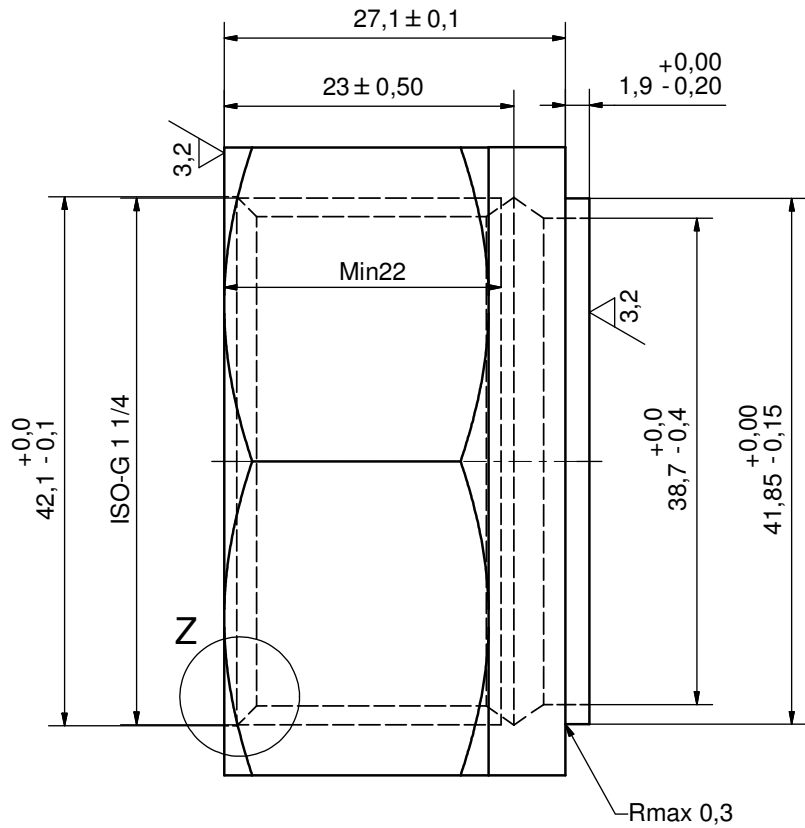

Z (5 : 1)

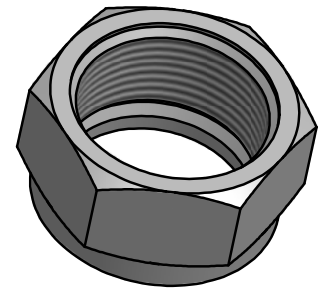
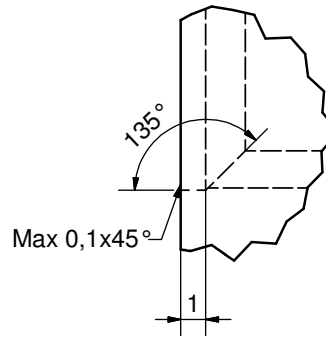
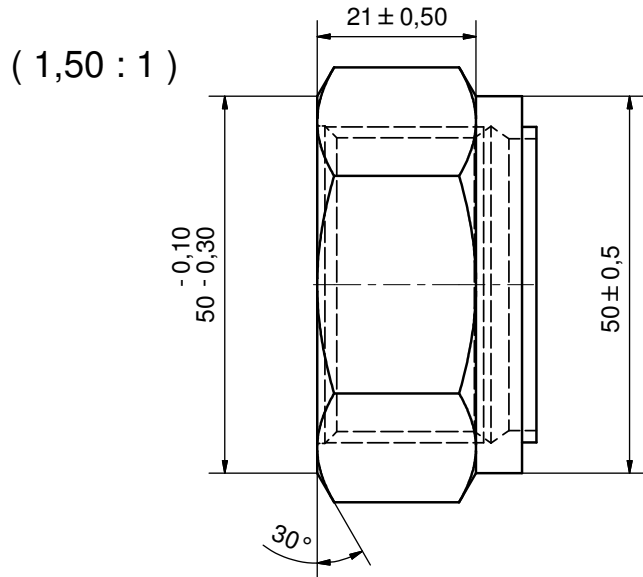

DEBURR SHARP EDGES; 0.4MAX

ACCORDING TO MQS
MATERIAL

Drawn	EG	Checked	TP	Approved	VP	Created Date	1992-08-21	General geometrical tolerancing ISO 2768	m	General surface finish Ra	3.2	Scale	-
Title							ISO-G 1 1/4" INT HEX						
Article number			Drawing number			Revision		Sheet					
-			CD000008			9		1 (1)					

AXINTRA
ÉCHANGEURS THERMIQUES

SWEP
A DOVER COMPANY

Rev No.	Alteration	Date	Checked	Approved
12	Changed "G" dimension from 25 to 23.5mm	2010/09/16	SKMZP	PDM

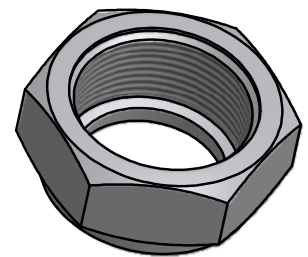
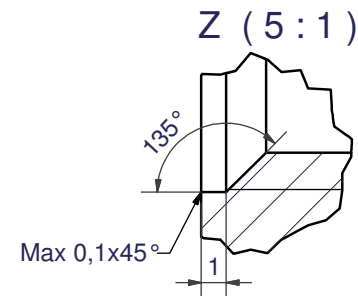
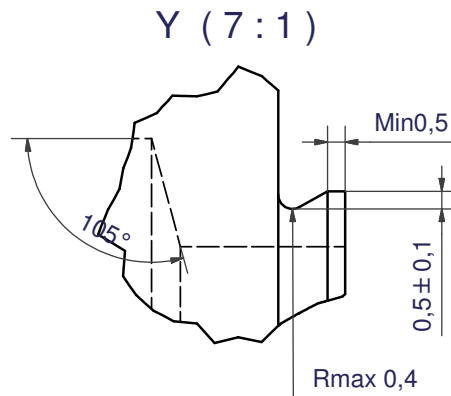
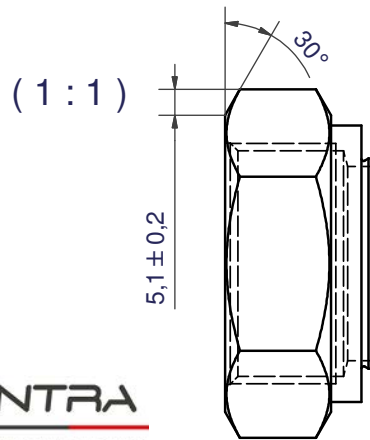
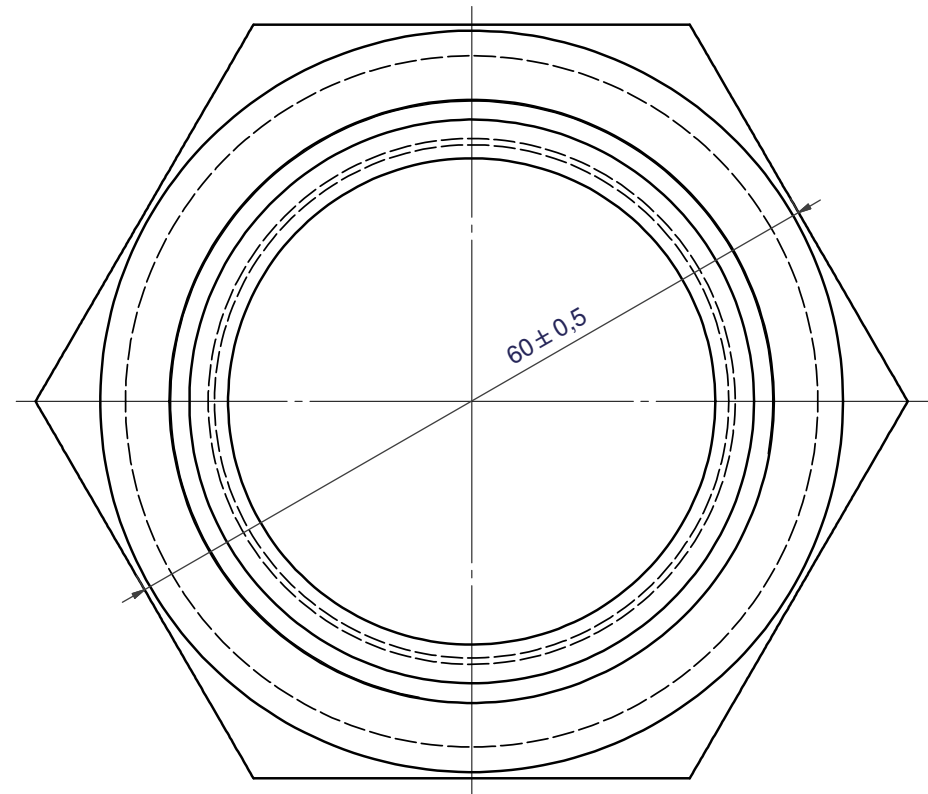
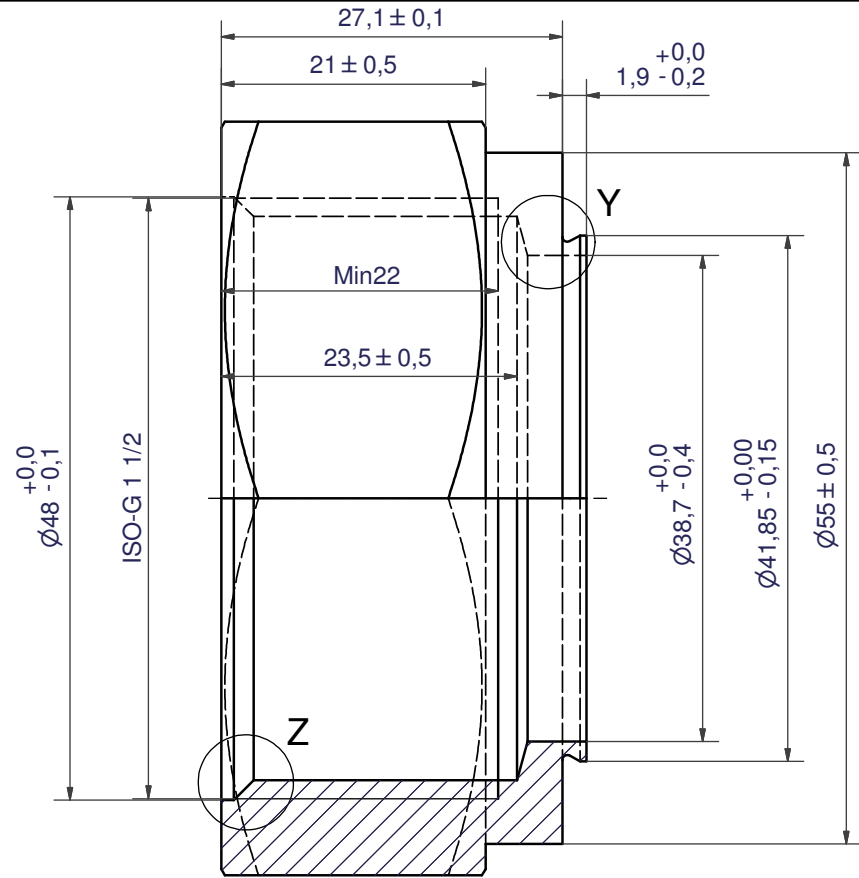

DEBURR SHARP EDGES; 0.4MAX

ACCORDING TO MQS
MATERIAL

Drawn	Checked	Approved	Created Date	General geometrical tolerancing ISO 2768	General surface finish Ra	Scale
EG	TP	VP	1992-05-05	m	3.2	-
			ISO-G 1 1/2" INT HEX			
Article number		Drawing number		Revision	Sheet	
-		CD000003		12	1 (1)	