

B35TM2

Le B35T est le produit idéal pour de nombreuses applications : chauffage urbain, récupération de chaleur, cogénération, refroidissement d'huile de transmission et de moteur. Il est le choix parfait pour bénéficier de transferts de chaleur efficaces et de faibles pertes de charges dans des systèmes de conduites jusqu'à 2 pouces et des débits d'eau jusqu'à 27 m³/h (118.8 gpm).



Spécifications de base

Nombre de plaques max. (NoP)	260
Débit volumétrique max.	58 m ³ /h (255.37 gpm)
Volume du canal	0.18/0.18 dm ³ (0.0064/0.0064 ft ³)
Matières	Plaques en acier inoxydable 316/316L, brasage cuivre
Poids sans les connexions	7.13+(0.2515*NoP) kg 15.71+(0.554*NoP) lb
Taille la taille des Particules (mm)	1

Les dimensions standard

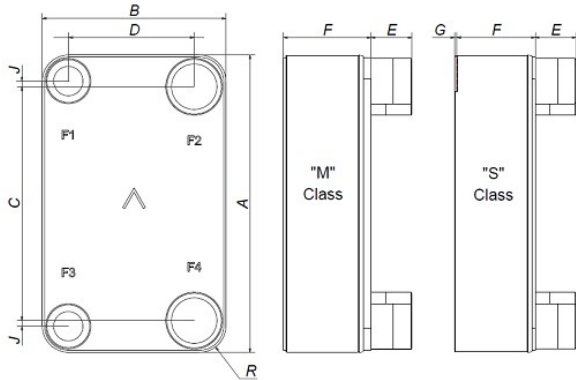

#	MM	IN
A	393	15.47
B	243	9.57
C	309	12.17
D	166.50	6.56
F	10,00+2,26*(NoP)	0.39+0.09*(NoP)
G	4	0.16
J	7.50	0.3
R	35	1.38
E_1	27	1.06
E_2	54	2.13

PED pression / température

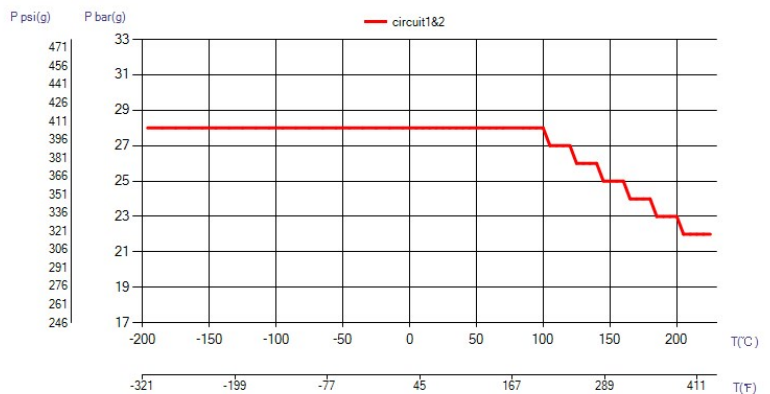

ÉCHANGEURS THERMIQUES

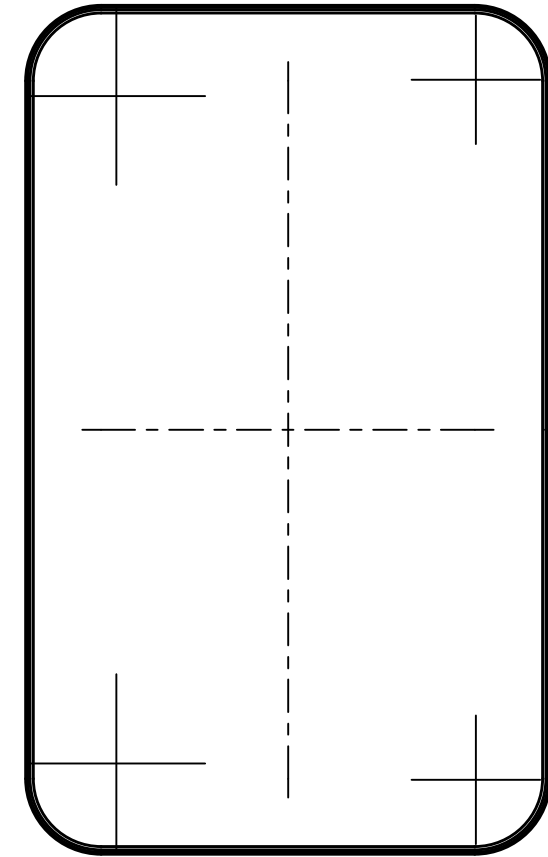
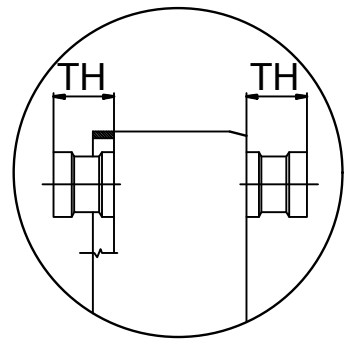
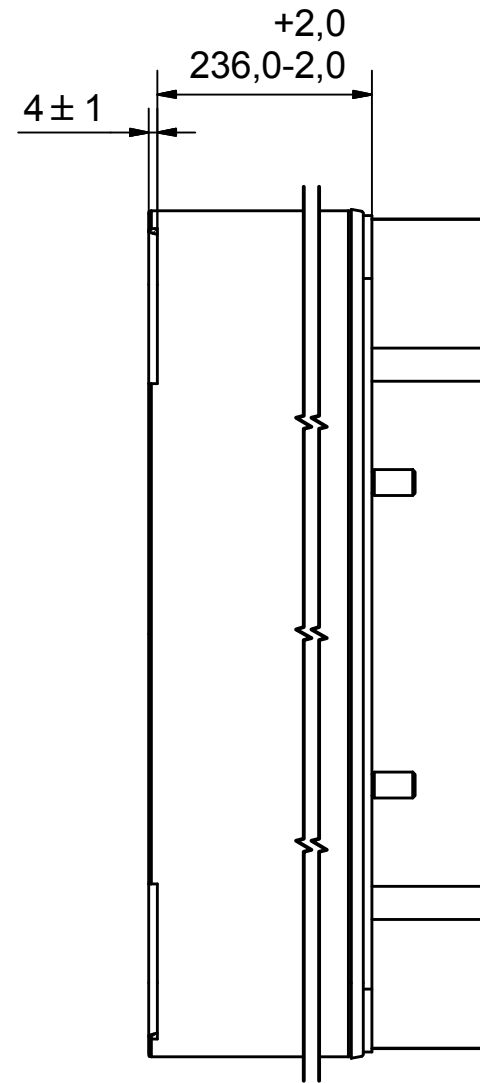
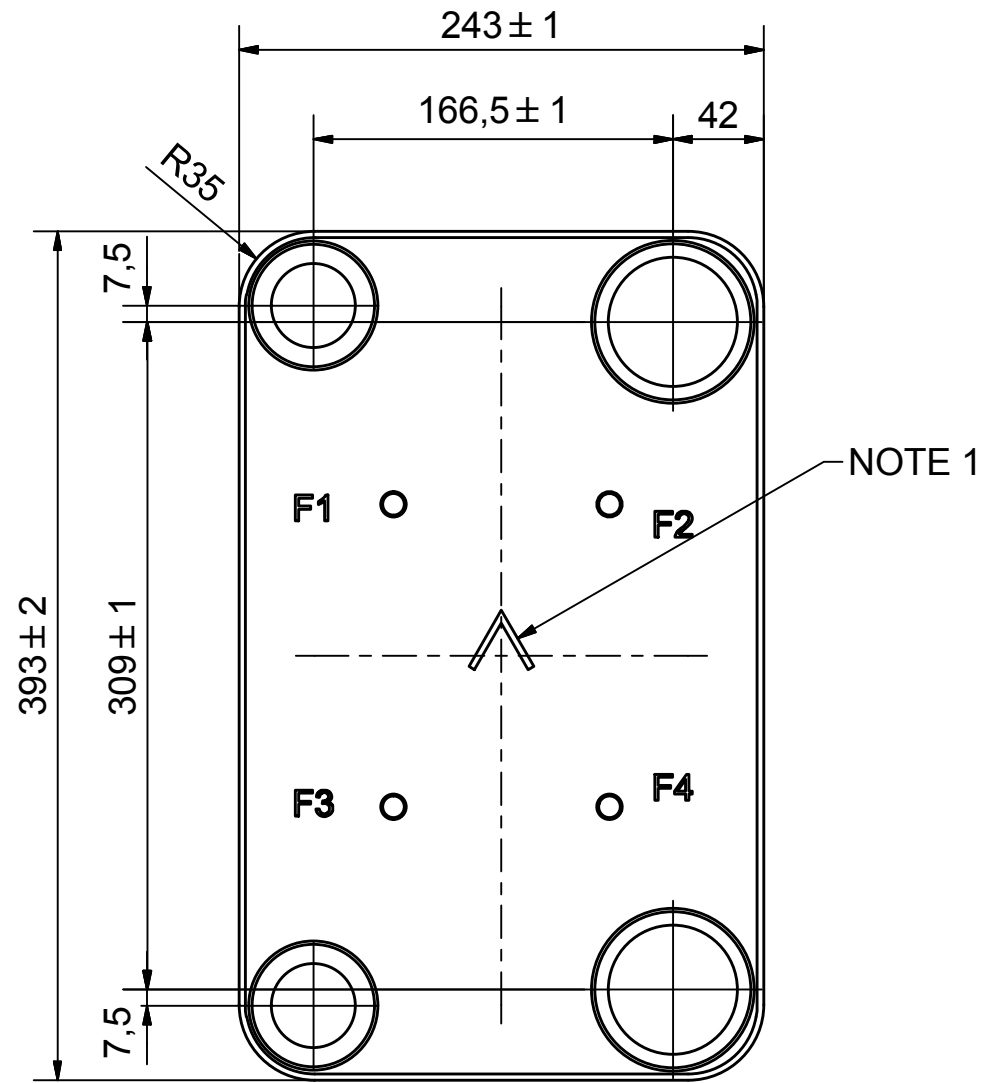



NOTE 1 ALTERNATE MARKING: STICKER OR STAMP



F4	45311	ISO-G 2 1/2 , TH = 54,2	CD000051
F3	45134	ISO-G 2 , TH = 54,2	CD000041
F2	45311	ISO-G 2 1/2 , TH = 54,2	CD000051
F1	45134	ISO-G 2 , TH = 54,2	CD000041
F	21112	B35 BOLT LOC F 4x C140x100	CG350001_1

Pos	Article No	Title / Denomination, code, material, dimension etc	Drawing No./ref	Pos	Article No	Title / Denomination, code, material, dimension etc	Drawing No./ref
-----	------------	---	-----------------	-----	------------	---	-----------------

Title		B35TM2/1P-SC-S	
 A DOVER COMPANY	Created Date	Created By	
	2018-04-11	AU	
Article/Configuration number		Drawing number	
16105-100		AU00366901	

Rev No.	Alteration	Date	Checked	Approved
2	REDRAWN IN INVENTOR	2004/12/10	PDM	PDM

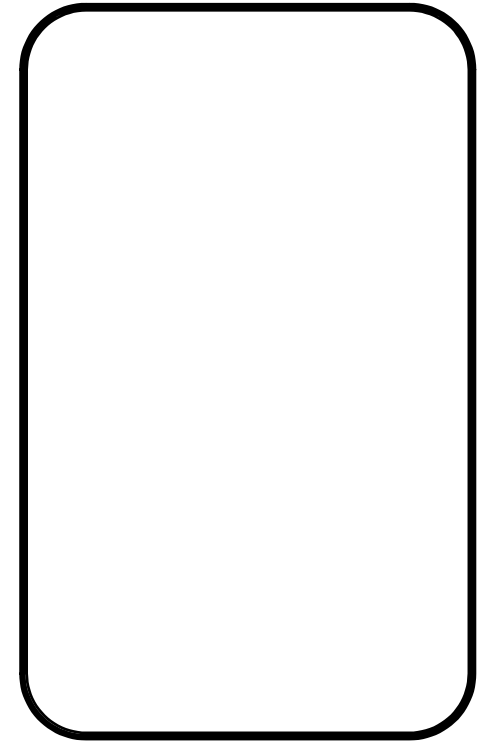
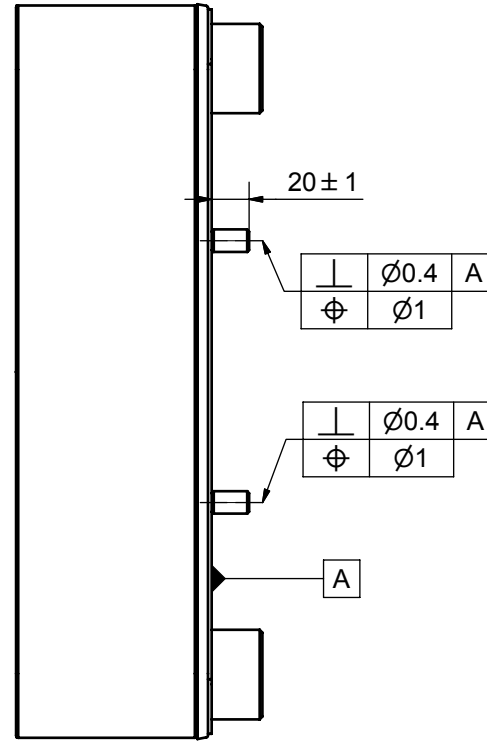
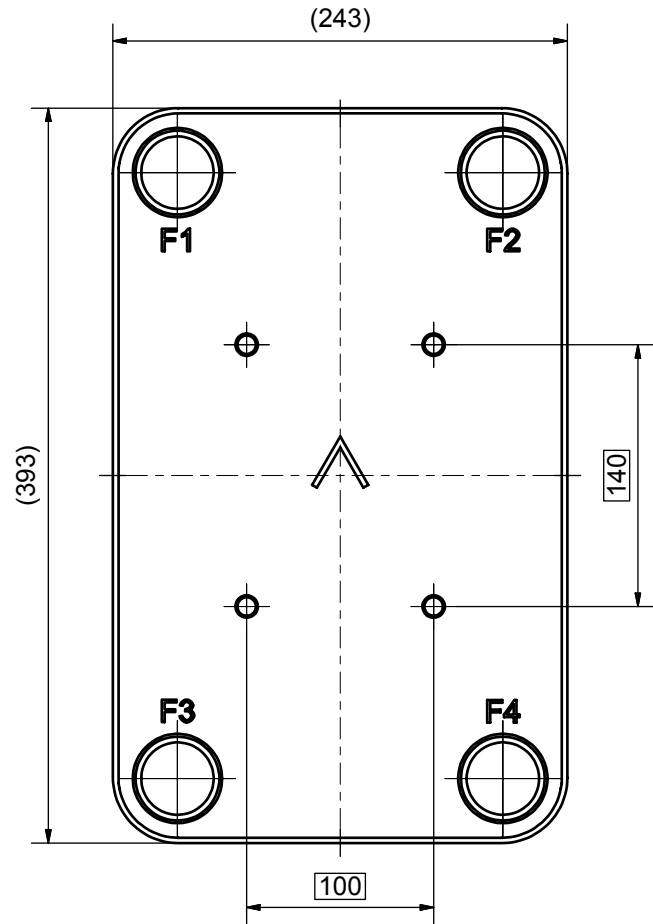

© Company Confidential, Property of SWEP International AB

1	4	STUD BOLT M12 x 20, ART. NO. 45095				M12 x 20
ITE	QTY	DESCRIPTION				Drawing No.
Drawn	Checked	Approved	Created Date	General geometrical tolerancing ISO 2768	General surface finish R_a	Scale
JA	PDM	PDM	2004/10/12	m	3.2	1:1
		Title				
		B35 BOLT LOC F 4x C140x100				
		Article number	Drawing number	Revision	Sheet	
		21112	CG350001	2	1 (1)	

Rev No.	Alteration	Date	Checked	Approved
10	DEBURRING INFO ADDED	2009/03/10	TL	PDM

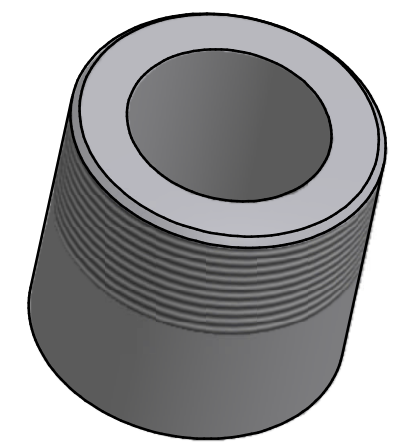
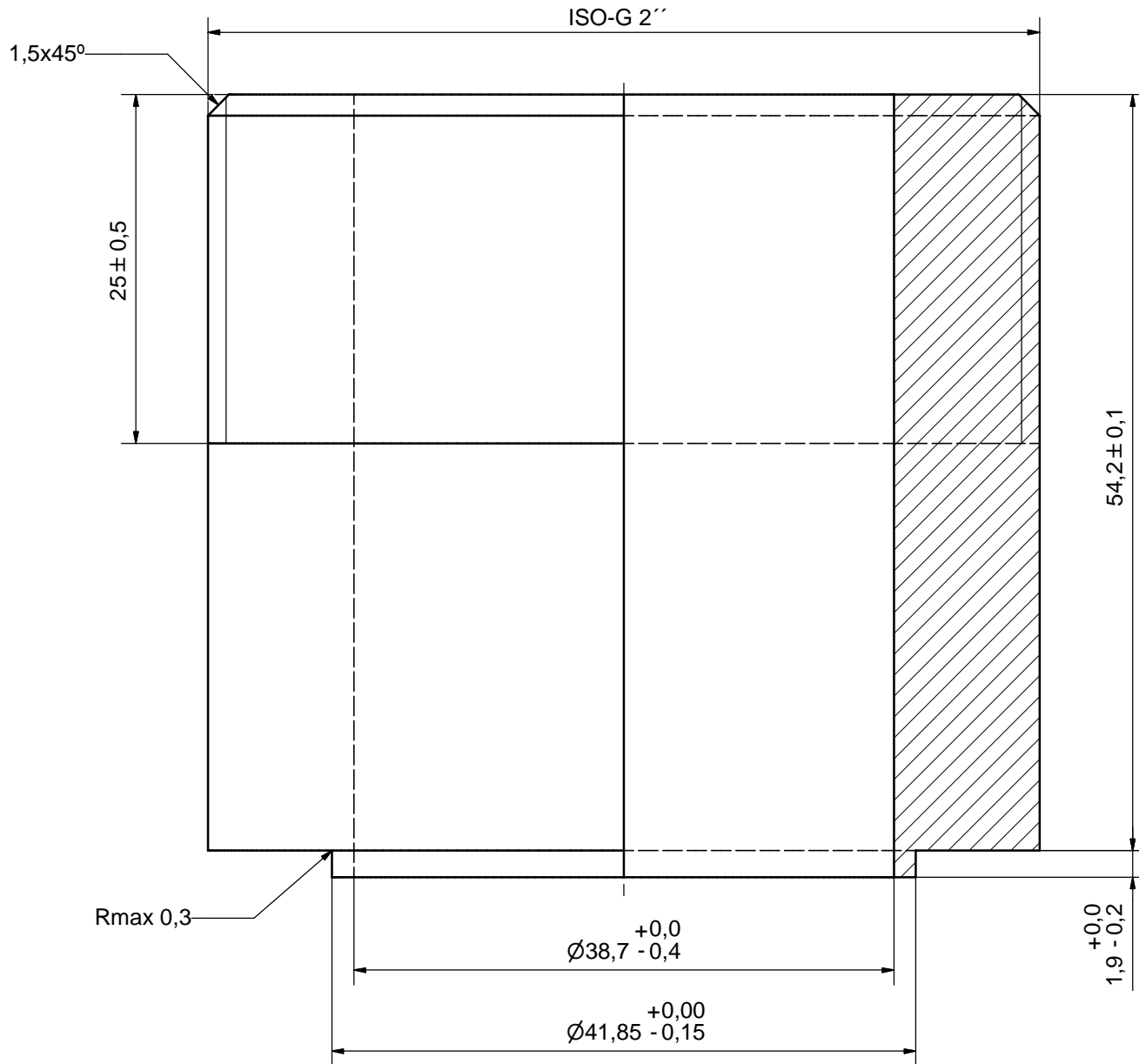

SHARP EDGES DEBURRED MAX 0,4

ACCORDING TO MQS
MATERIAL

Drawn	Checked	Approved	Created Date	General geometrical tolerancing ISO 2768	General surface finish R_a	Scale
SA	TP	VP	1990-09-08	m	3.2	-
Title				ISO-G 2		
Article number		Drawing number		Revision	Sheet	
-		CD000041		10	1 (1)	

© Company Confidential, Property of SWEP International AB

