

B185

La demande en réfrigérants naturels tels que le CO2 est en augmentation. Pour des applications au CO2 transcritique nécessitant des pressions approchant 140 bar, le B185 se présente comme un choix évident. Le B185 est optimisé pour des puissances de refroidissement de gaz élevées (jusqu'à 350 kW en tant que refroidisseur de gaz). Grâce à son design à la fois compact et léger, le B185 est adapté aux applications de la chaîne du froid (hypermarchés, supermarchés, récupération de chaleur) et aux pompes de chaleur (évaporateurs, refroidisseurs de gaz).



Spécifications de base

Nombre de plaques max. (NoP)	180
Débit volumétrique max.	38,8 m³/h (35.22 gpm)
Volume du canal	0.1106/0.1169 dm³ (0.0039/0.0041 ft³)
Matières	Plaques en acier inoxydable 316, brasage cuivre
Poids sans les connexions	11.33+(0.4366*NoP) kg 24.98+(0.963*NoP) lb

Les dimensions standard

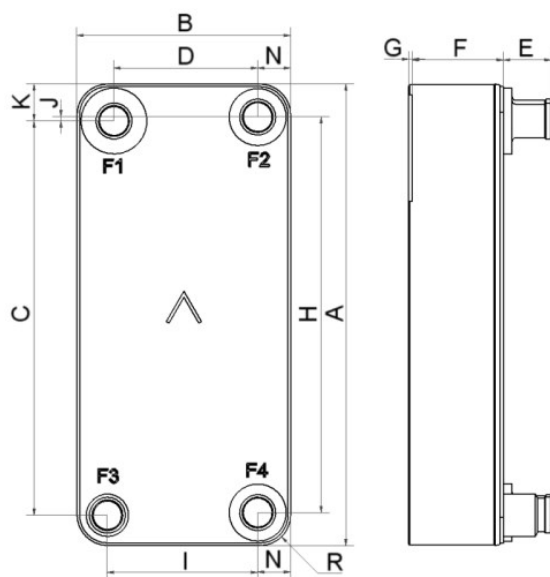

#	MM	IN
A	425.20	16.74
B	203.20	8
C	354	13.94
D	126	4.96
F	18.00+2.00*(NoP)	0.71+0.08*(NoP)
G	0	0
H	342	13.46
J	6	0.24
K	35.60	1.4
N	41.60	1.64
R	41.60	1.64
E_1	45	1.77

PED pression / température

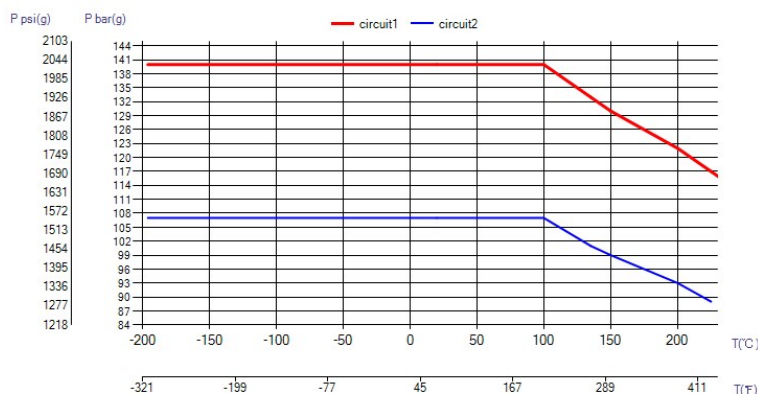

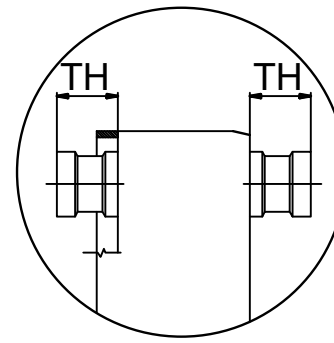
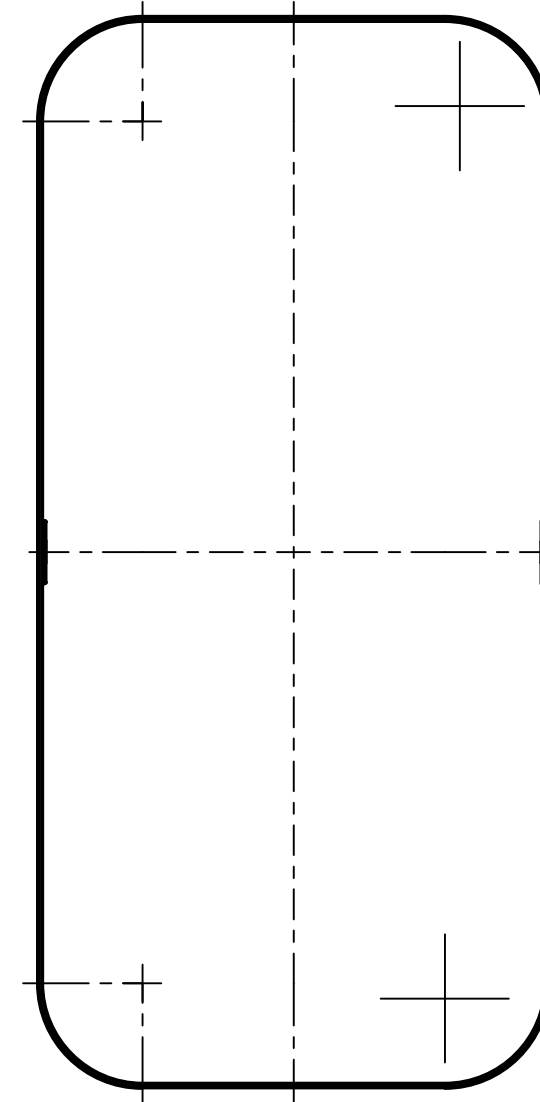
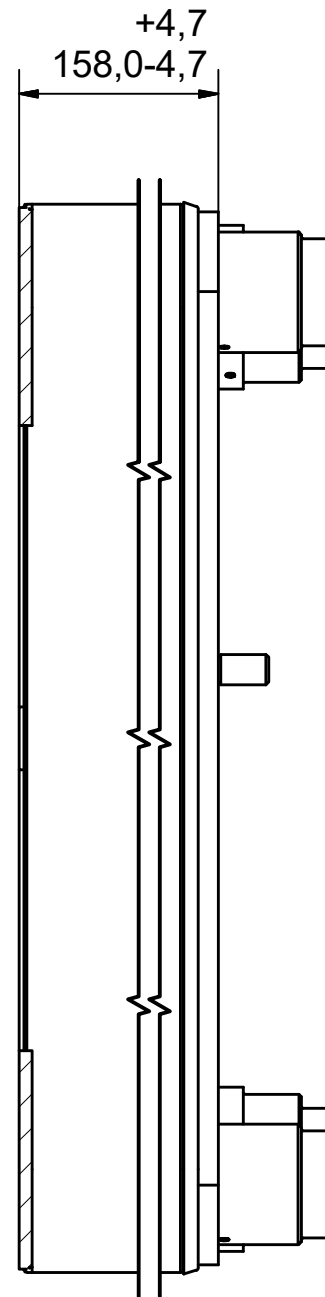
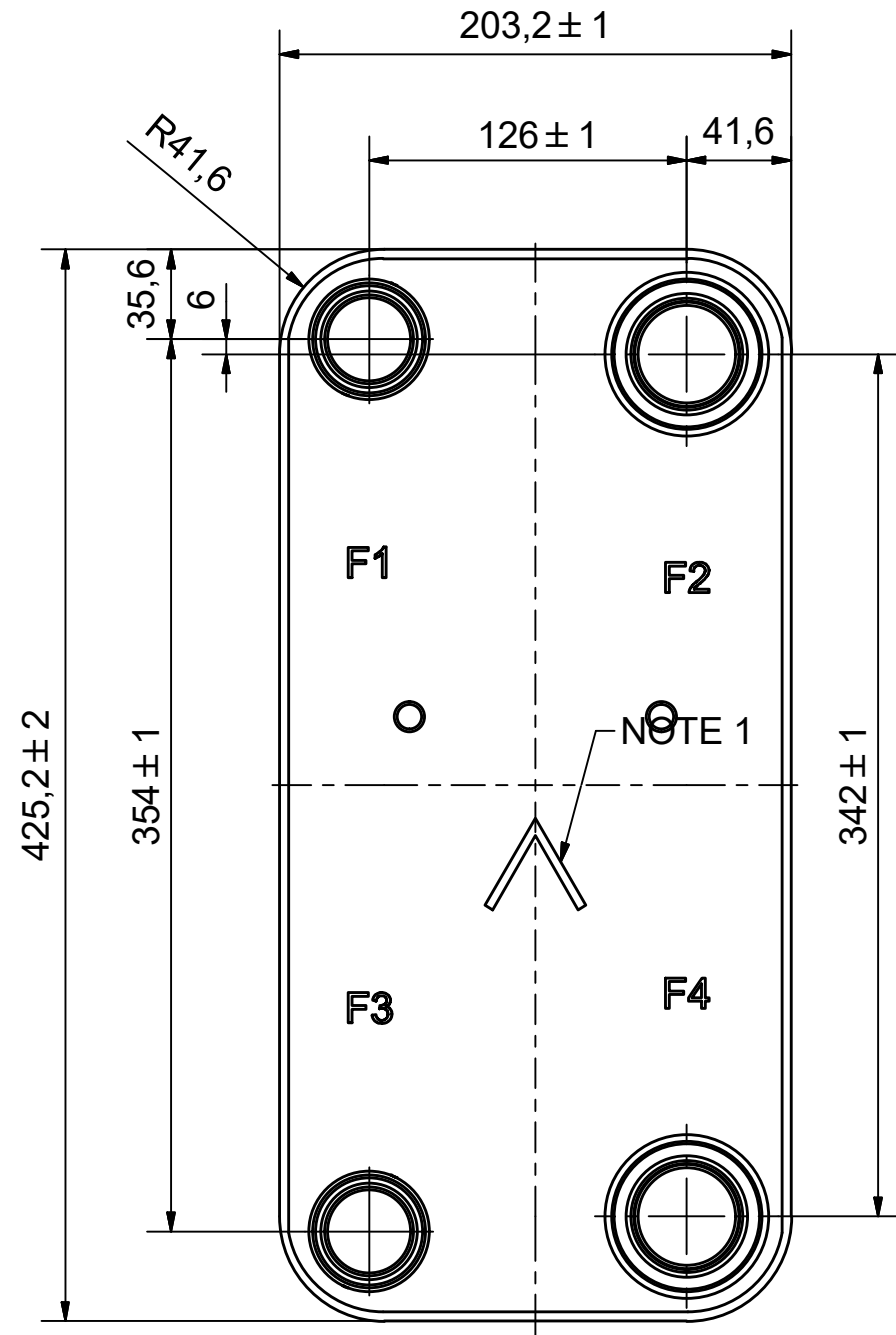

ÉCHANGEURS THERMIQUES



NOTE 1 ALTERNATE MARKING: STICKER OR STAMP

F4	61091	ISO-G 2" A, WELD 48,3 & SOLDER 42U, TH = 45,1	00029002
F3	60627	ISO-G 1 1/2" A, WELD 42,4 & SOLDER 35,1, TH = 45,1	00024296
F2	61091	ISO-G 2" A, WELD 48,3 & SOLDER 42U, TH = 45,1	00029002
F1	60627	ISO-G 1 1/2" A, WELD 42,4 & SOLDER 35,1, TH = 45,1	00024296
F	21973	185 STUD BOLT LOC. 2x100	00033057_1

Pos	Article No	Title / Denomination, code, material, dimension etc	Drawing No./ref	Pos	Article No	Title / Denomination, code, material, dimension etc	Drawing No./ref
-----	------------	---	-----------------	-----	------------	---	-----------------

Title		B185H/1P-SC-U	
 A DOVER COMPANY	Created Date	Created By	
	2024-01-10	AU	
	Article/Configuration number	Drawing number	
	16891-70	AU00774727_16891-70	

Rev No	Alteration	Date	Checked	Approved
00				PDM

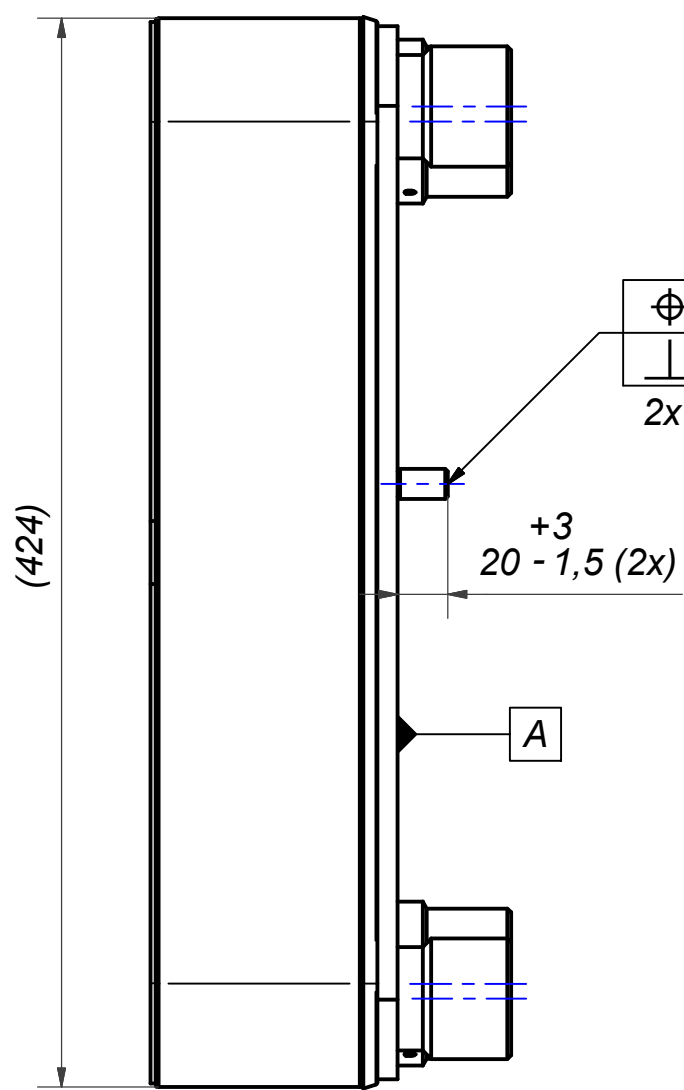
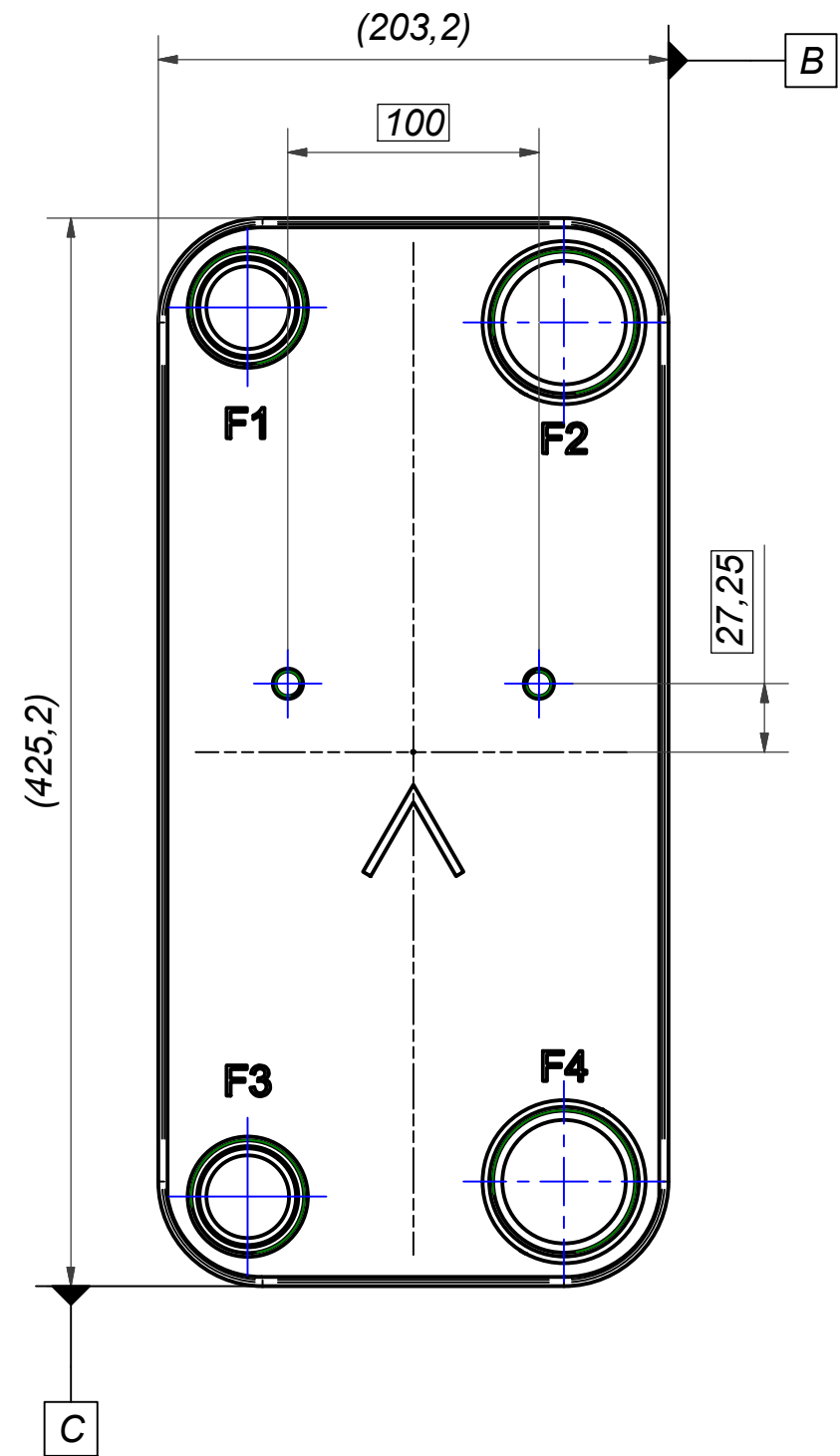

\varnothing	$\varnothing 2$	A	B	C
\perp	$\varnothing 0,4$	A		
2x				

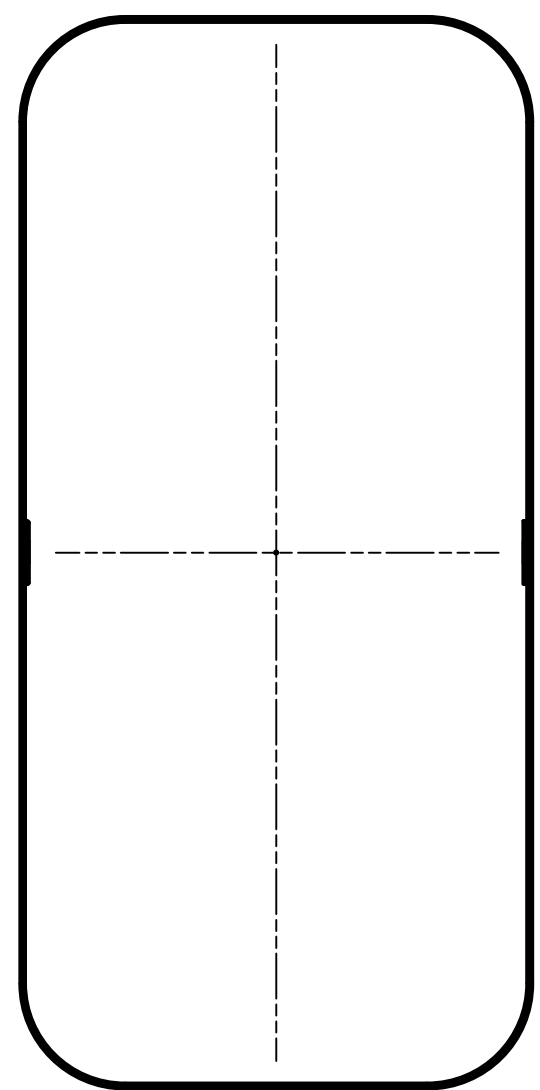

© Company Confidential, Property of SWEP International AB

1	2	STUD BOLT ART. NO. 45095				M12 x 20		
Item	QTY	Description				Drawing / Article		
Drawn	Checked	Approved	Created Date	General geometrical tolerancing ISO 2768:	General surface finish R_a :	Scale	Paper size	
skds	PDM	PDM	2016-12-12			-	A3	
						Title		
						185 STUD BOLT LOC. F 2x100x27,25		
Article number		Design Type	Drawing number	Revision	Sheet			
21973		CG	00033057	00	1 (1)			

Rev No	Alteration	Date	Checked	Approved
00				PDM

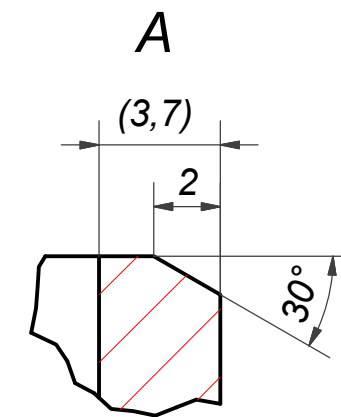
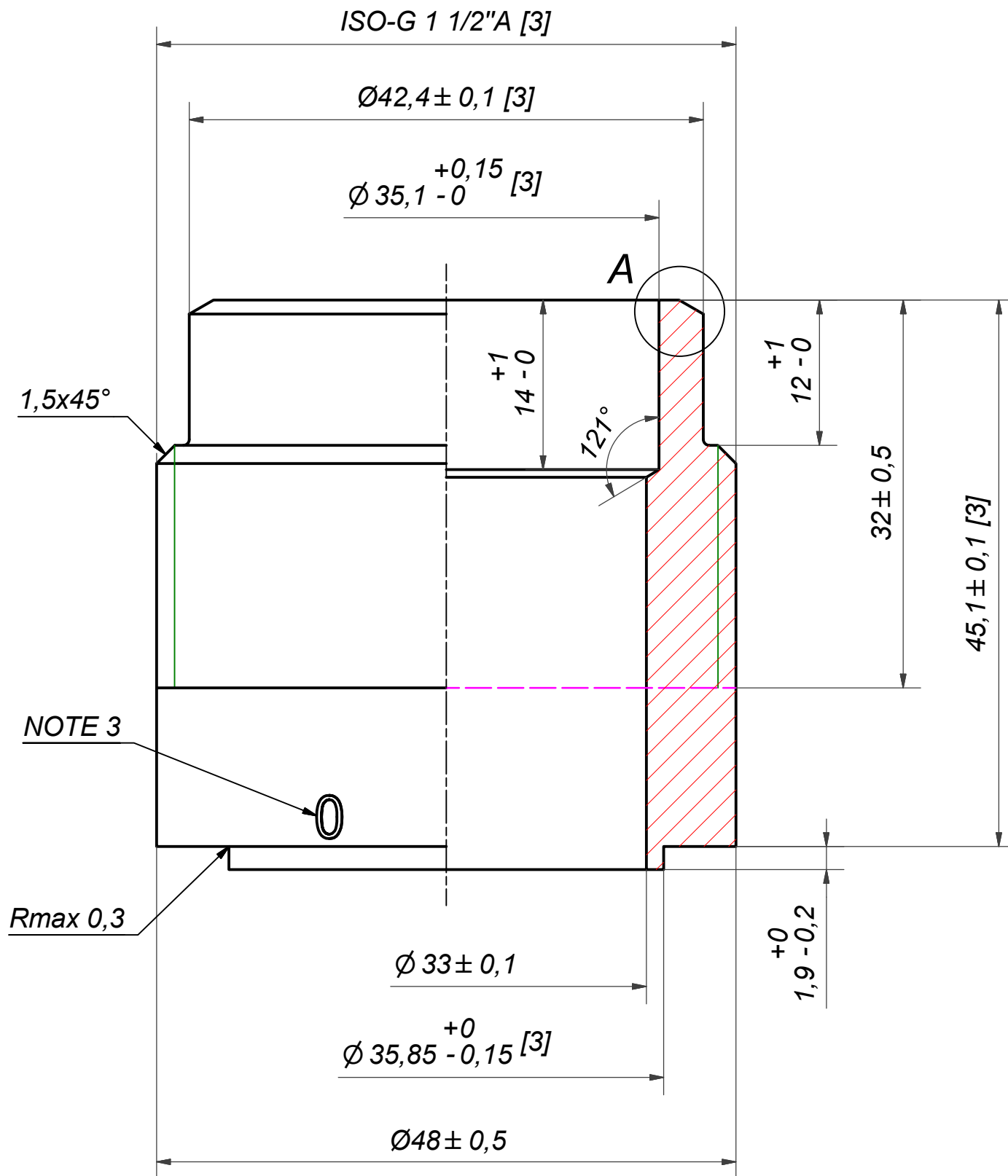
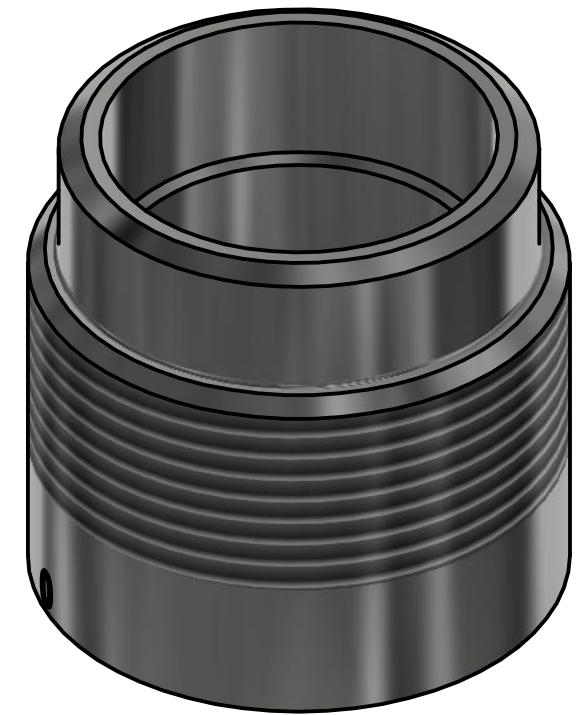

**NOTE 3: MARKING TEXT "0" FOR IDENTIFICATION ONLY
PRESENT AT 2 PLACES 180° FROM EACH OTHER
"0" = 304 MATERIAL**

NOTE 2: [3] - CRITICAL/SPECIAL CHARACTERISTIC TO BE FOLLOWED

NOTE 1: DEBURR SHARP EDGES; MAX 0.4

ACCORDING TO MQS
MATERIAL

Drawn	Checked	Approved	Created Date	General geometrical tolerancing ISO 2768:	General surface finish R_a :	Scale	Paper size
skmtb	PDM	PDM	2015-02-04	m	3.2		A3
			ISO-G 1 1/2" A, WELD 42,4 & SOLDER 35,1				
			Article number	Design Type	Drawing number	Revision	Sheet
			CD	00024296	00	1 (1)	

Rev No	Alteration	Date	Checked	Approved
00				PDM

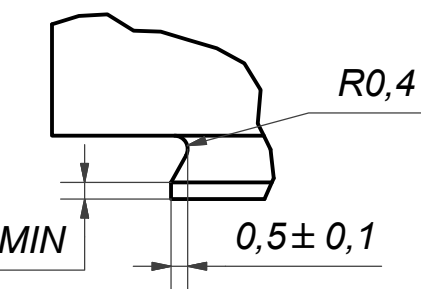
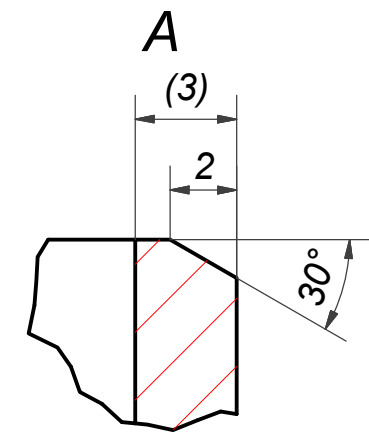
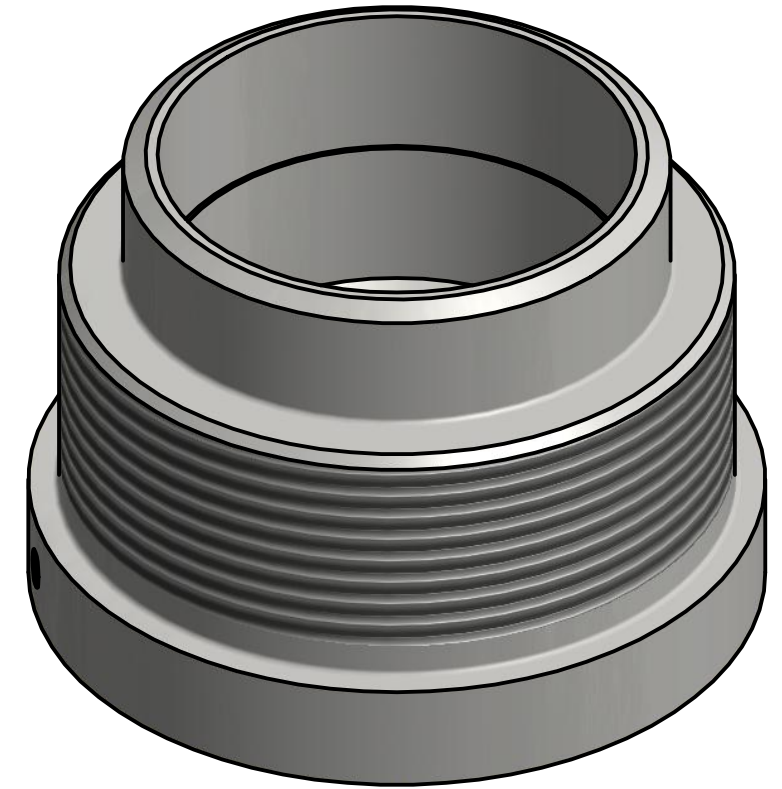
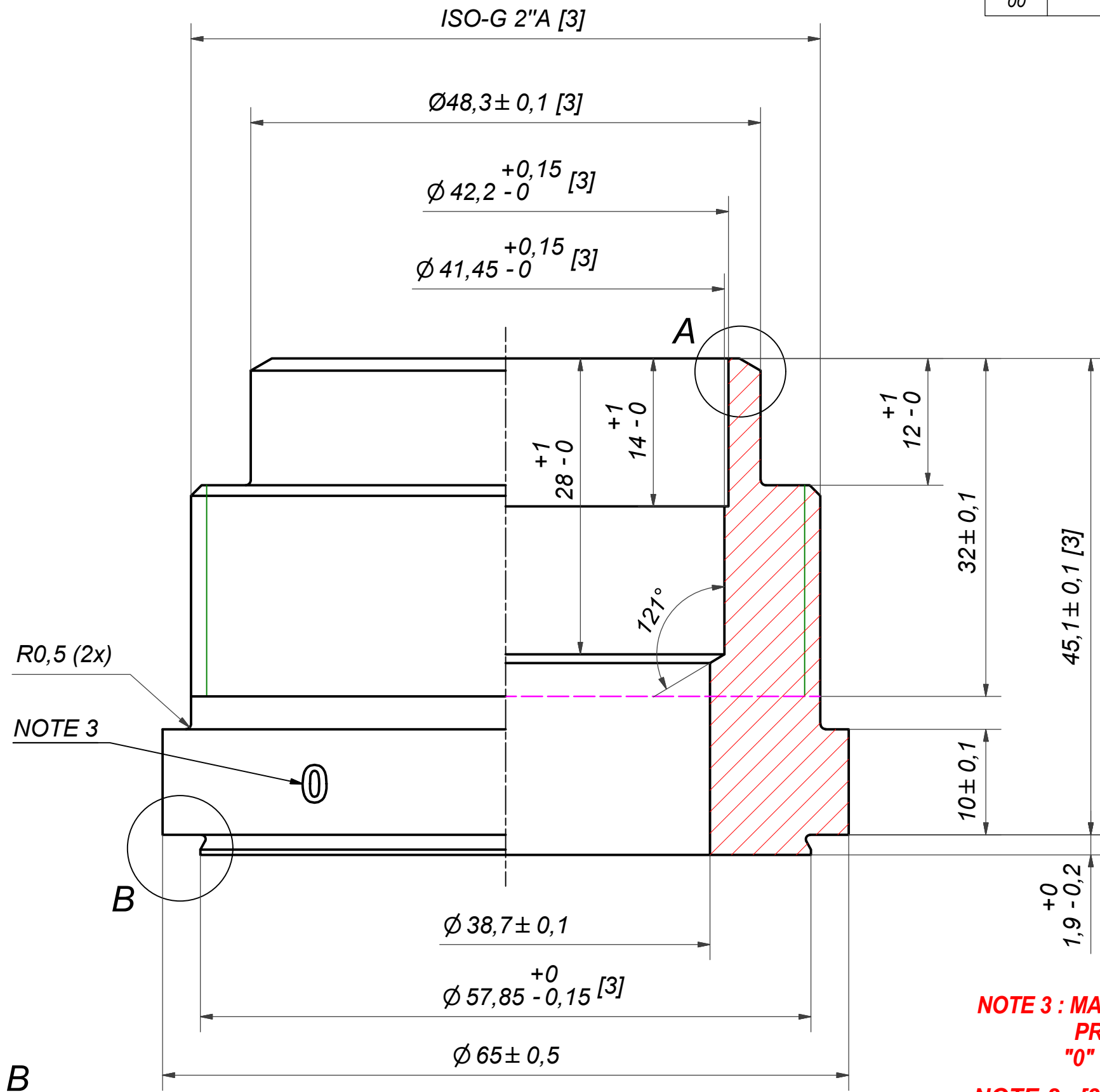

**NOTE 3 : MARKING TEXT "0" FOR IDENTIFICATION ONLY
PRESENT AT 2 PLACES 180° FROM EACH OTHER
"0" = 304 MATERIAL**

NOTE 2 : [3] - CRITICAL/SPECIAL CHARACTERISTIC TO BE FOLLOWED

NOTE 1: DEBURR SHARP EDGES; MAX 0.4

ACCORDING TO MQS
MATERIAL

Drawn	Checked	Approved	Created Date	General geometrical tolerancing ISO 2768:	General surface finish R_a :	Scale	Paper size
skmtb	PDM	PDM	2016-02-11	m	3.2	-	A3
			Title				
			ISO-G 2" A, WELD 48,3 & SOLDER 42U				
Article number		Design Type	Drawing number	Revision	Sheet		
		CD	00029002	00	1 (1)		