

# B35

Le B35 est le produit idéal pour de nombreuses applications : chauffage urbain, récupération de chaleur, cogénération, refroidissement d'huile de transmission et de moteur. Il est le choix parfait pour bénéficier de transferts de chaleur efficaces et de faibles pertes de charges dans des systèmes de conduites jusqu'à 2 pouces et des débits d'eau jusqu'à 27 m<sup>3</sup>/h (118.8 gpm).



## Spécifications de base

Nombre de plaques max. (NoP)	250
Débit volumétrique max.	27,4 m <sup>3</sup> /h (17.61 gpm)
Volume du canal	0.179/0.179 dm <sup>3</sup> (0.0063/0.0063 ft <sup>3</sup> )
Matières	Plaques en acier inoxydable 316, brasage cuivre
Poids sans les connexions	905.00+(0.34*NoP) kg 1995.16+(74.956*NoP) lb

## Les dimensions standard

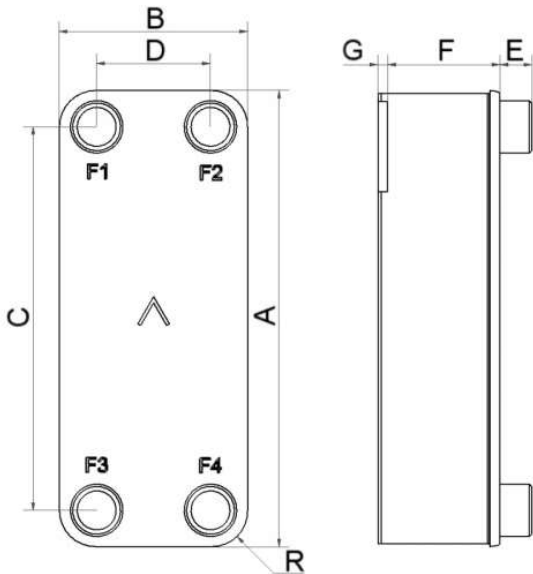

#	MM	N
A	393	15.47
B	243	9.57
C	324	12.76
D	174	6.85
F	8.00+2.34*(NoP)	0.31+0.09*(NoP)
G	3	0.12
R	35	1.38
E_1	27	1.06

## PED pression / température

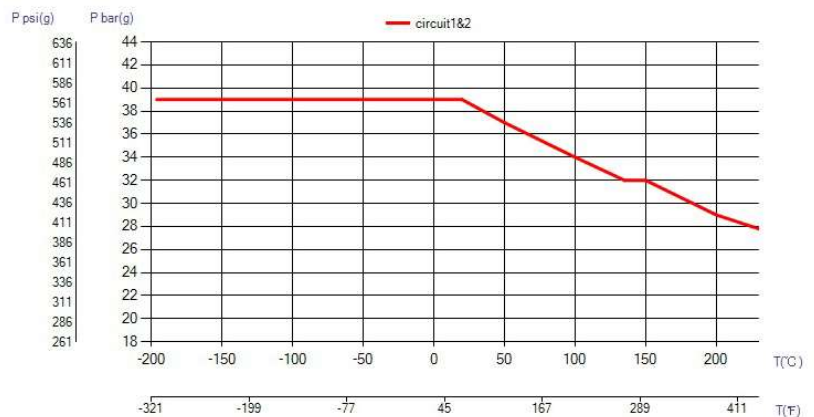

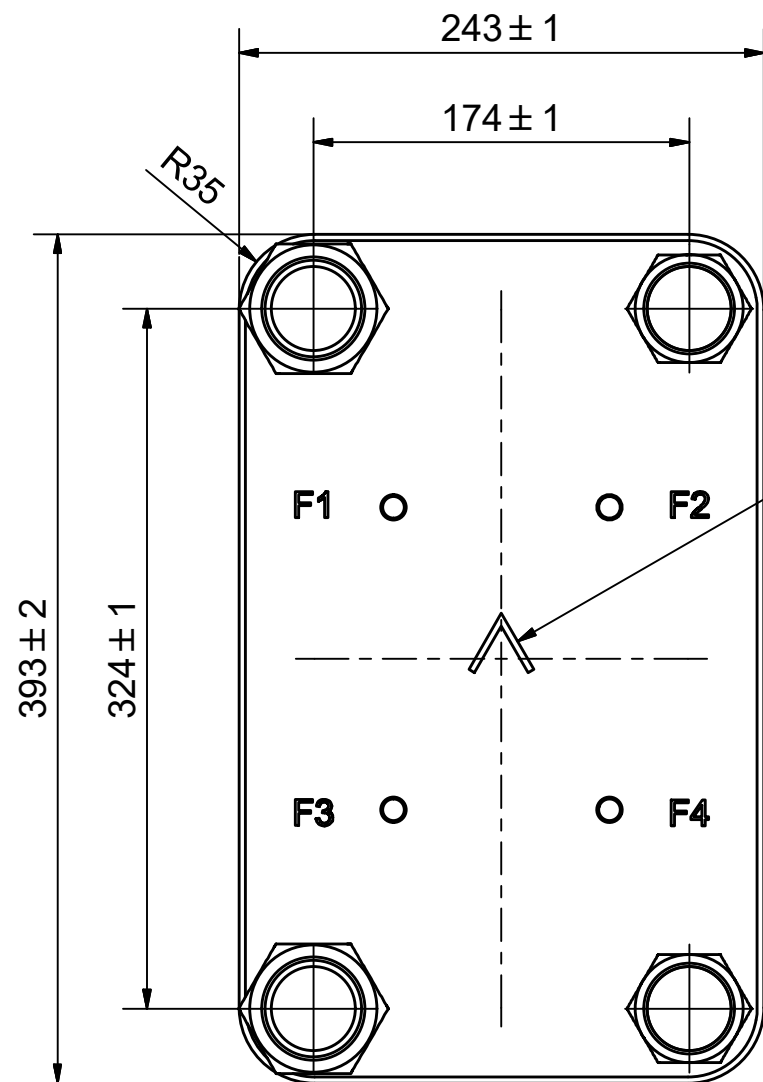

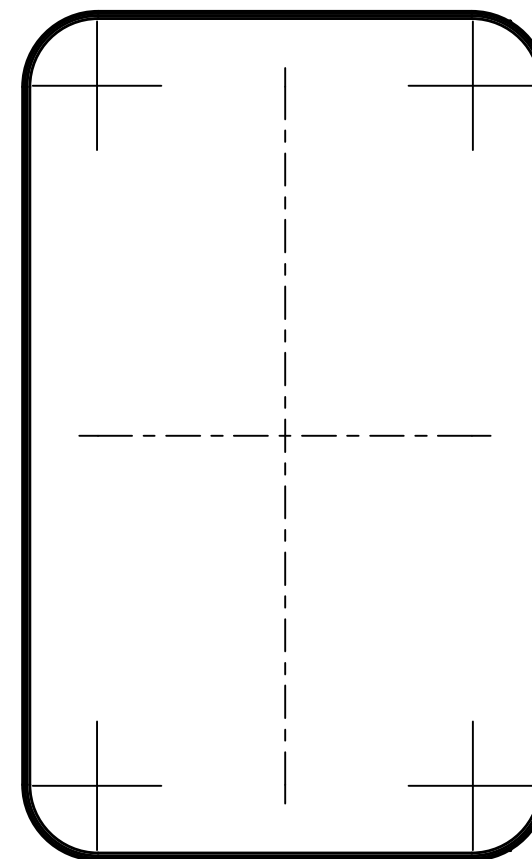
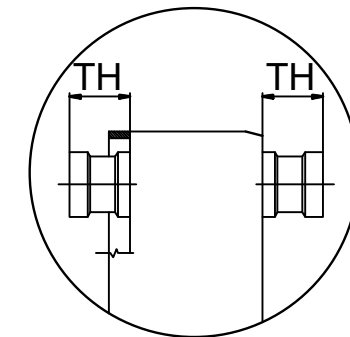
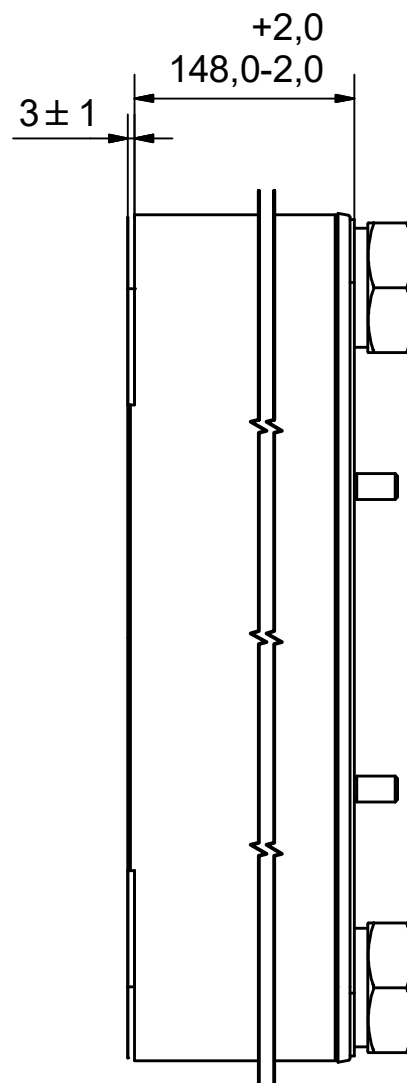

NOTE 1



**AXINTRA**  
ÉCHANGEURS THERMIQUES

NOTE 1 ALTERNATE MARKING: STICKER OR STAMP

F4	45427	ISO-G 1 1/4" INT HEX, TH = 27,1	CD000008
F3	45405	ISO-G 1 1/2" INT HEX, TH = 27,1	CD000003
F2	45427	ISO-G 1 1/4" INT HEX, TH = 27,1	CD000008
F1	45405	ISO-G 1 1/2" INT HEX, TH = 27,1	CD000003
F	21112	B35 BOLT LOC F 4x C140x100	CG350001_1

Title		B35H/1P-SC-S	
 A DOVER COMPANY	Created Date	Created By	
	2019-01-08	AU	
Article/Configuration number		Drawing number	
10379-060		AU00448872	

Pos	Article No	Title / Denomination, code, material, dimension etc	Drawing No./ref	Pos	Article No	Title / Denomination, code, material, dimension etc	Drawing No./ref
-----	------------	---	-----------------	-----	------------	---	-----------------

Rev No.	Alteration	Date	Checked	Approved
2	REDRAWN IN INVENTOR	2004/12/10	PDM	PDM

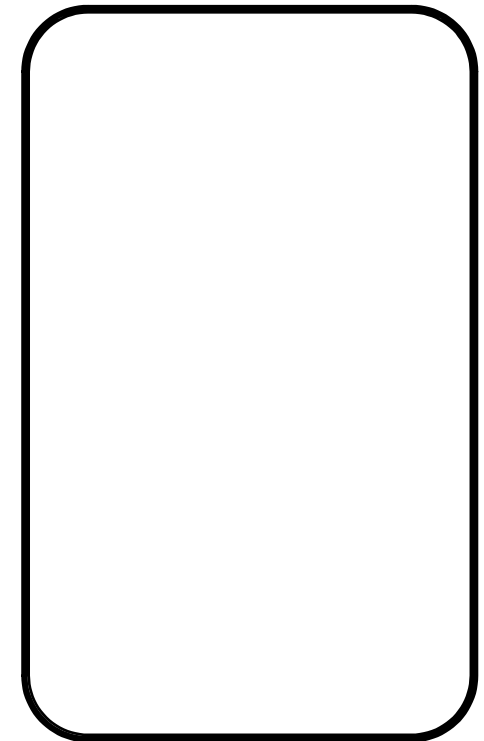
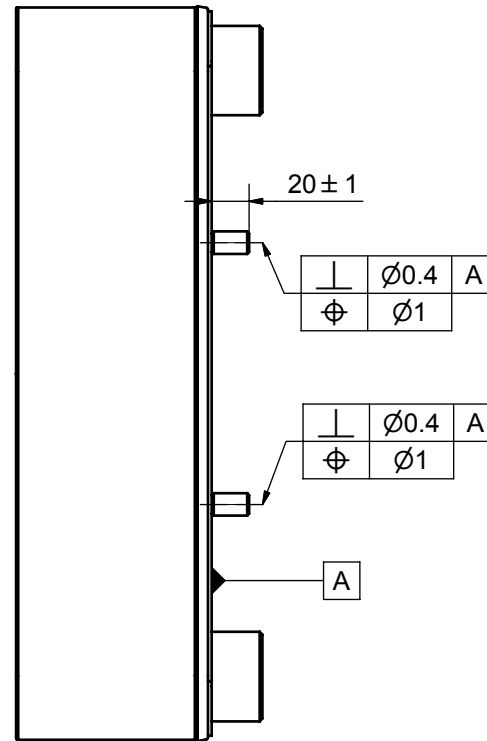
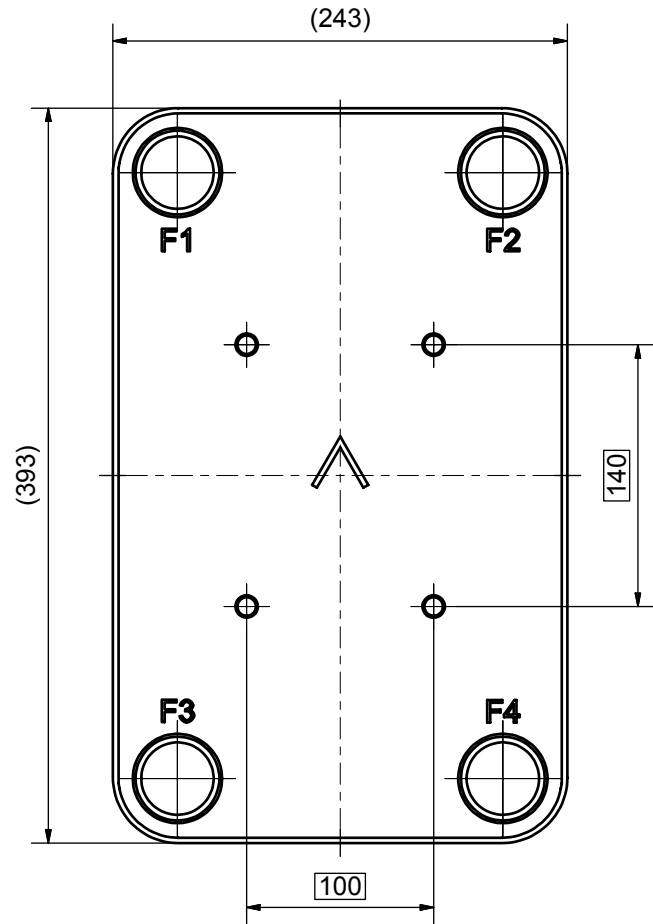

© Company Confidential, Property of SWEP International AB

1	4	STUD BOLT M12 x 20, ART. NO. 45095				M12 x 20
ITE	QTY	DESCRIPTION				Drawing No.
Drawn	Checked	Approved	Created Date	General geometrical tolerancing ISO 2768	General surface finish $R_a$	Scale
JA	PDM	PDM	2004/10/12	m	3.2	1:1
		Title				
		B35 BOLT LOC F 4x C140x100				
		Article number	Drawing number	Revision	Sheet	
		21112	CG350001	2	1 (1)	

Rev No.	Alteration	Date	Checked	Approved
12	Changed "G" dimension from 25 to 23.5mm	2010/09/16	SKMZP	PDM

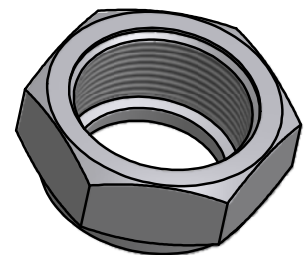
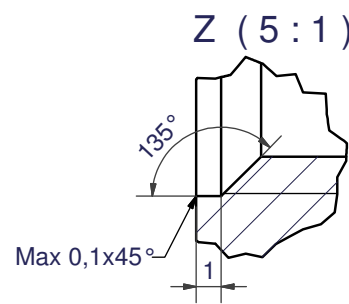
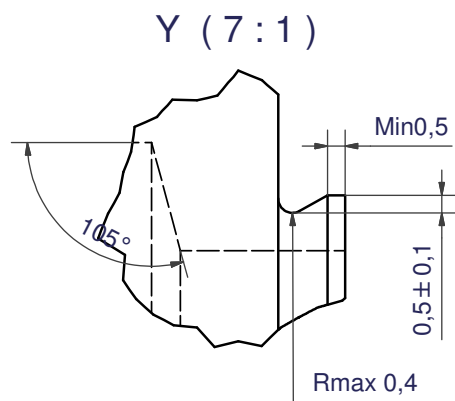
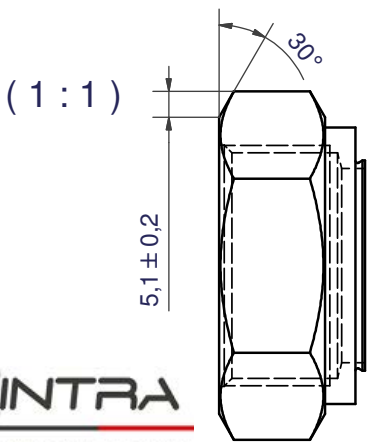
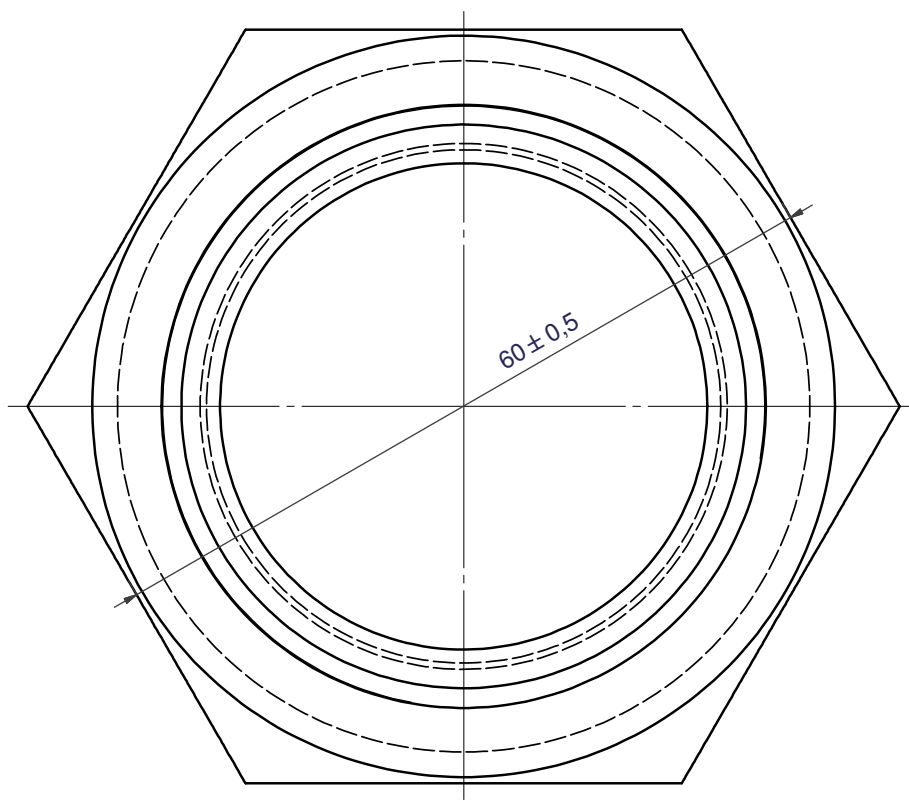
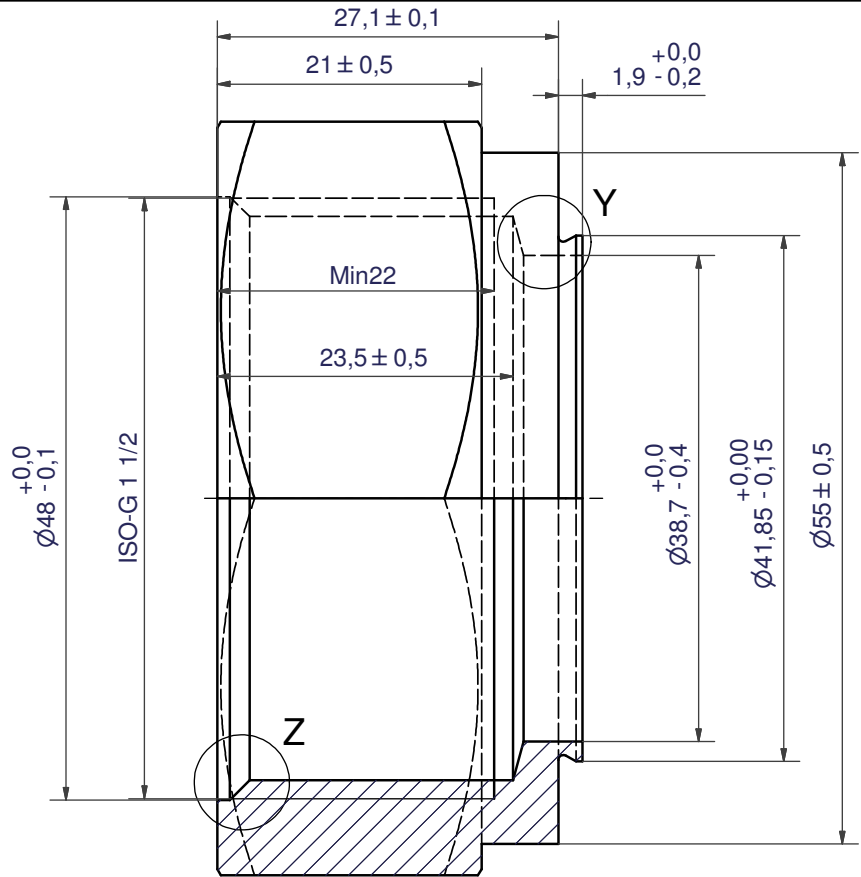

DEBURR SHARP EDGES; 0.4MAX

ACCORDING TO MQS  
MATERIAL

Drawn	Checked	Approved	Created Date	General geometrical tolerancing ISO 2768	General surface finish Ra	Scale
EG	TP	VP	1992-05-05	m	3.2	-
			<b>ISO-G 1 1/2" INT HEX</b>			
Article number		Drawing number		Revision	Sheet	
-		CD000003		12	1 (1)	

© Company Confidential, Property of SWEP International AB

**AXINTRA**  
ÉCHANGEURS THERMIQUES

Rev No.	Alteration	Date	Checked	Approved
9	ADDED DEBURR AND MATERIAL INFO	2009/07/28	RJ	PDM

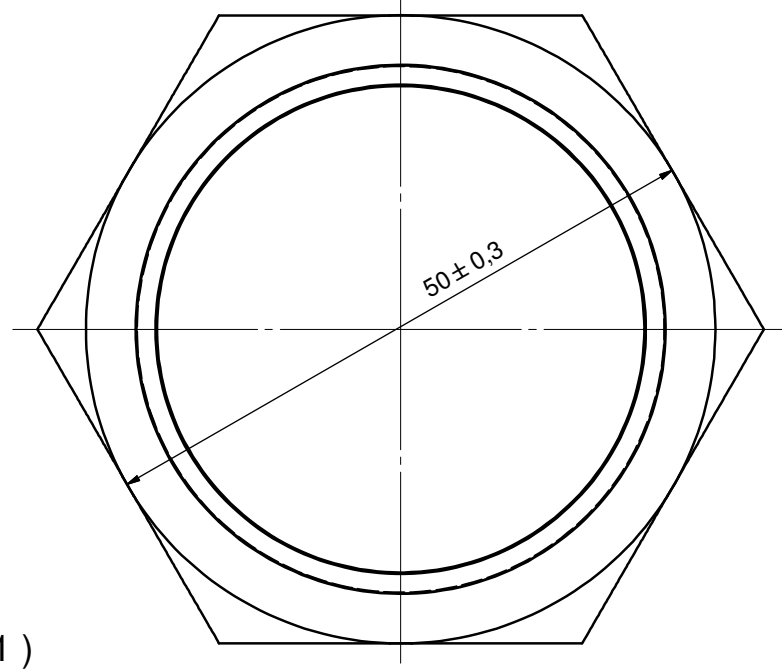
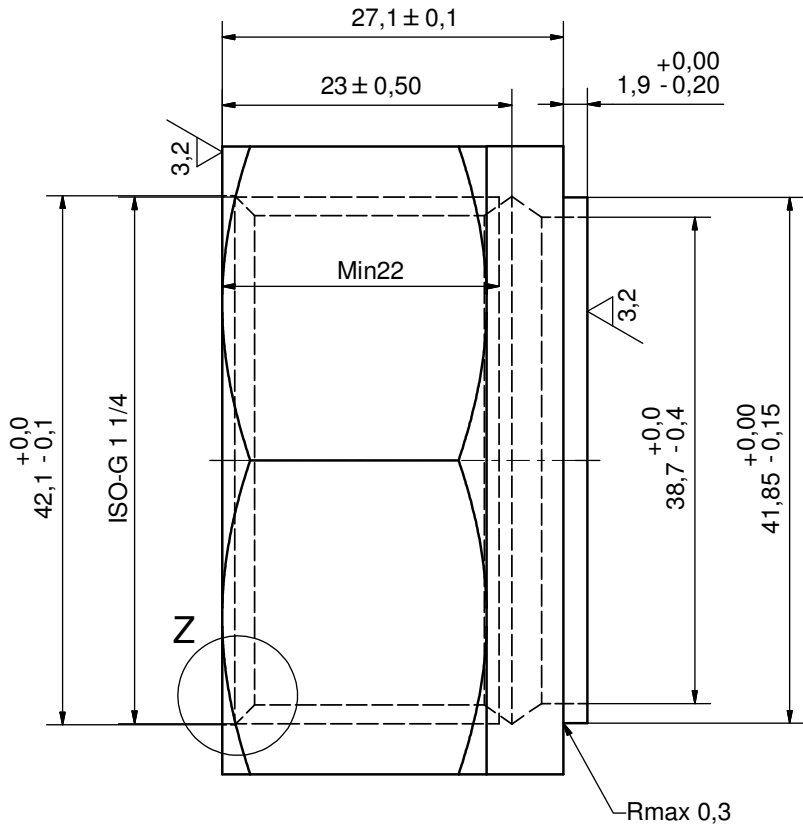

Z (5 : 1)

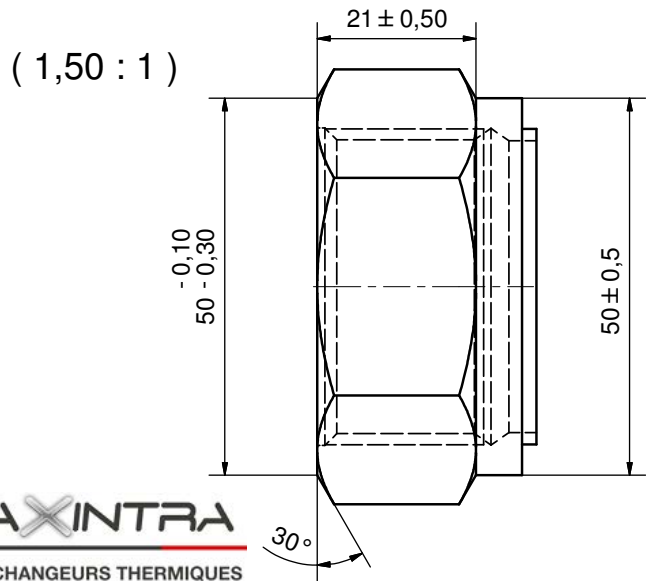
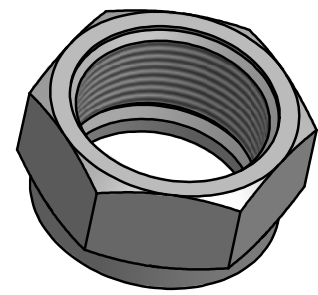
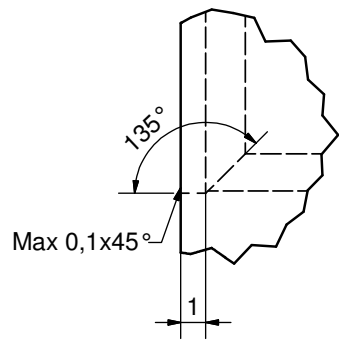

DEBURR SHARP EDGES; 0.4MAX

ACCORDING TO MQS  
MATERIAL

Drawn	Checked	Approved	Created Date	General geometrical tolerancing ISO 2768	General surface finish Ra	Scale
EG	TP	VP	1992-08-21	m	3.2	-
			<b>ISO-G 1 1/4" INT HEX</b>			
Article number		Drawing number		Revision	Sheet	
-		CD000008		9	1 (1)	

© Company Confidential, Property of SWEP International AB

**AXINTRA**  
ÉCHANGEURS THERMIQUES