

B25T

Le modèle B25T propose des solutions d'échange thermique efficace pour une large fourchette de capacités. La polyvalence et l'excellent transfert thermique de ce produit en font le choix idéal pour les applications eau/eau exigeantes et comme de très performance condenseurs.



Spécifications de base

Nombre de plaques max. (NoP)	140
Débit volumétrique max.	9 m³/h (39.63 gpm)
Volume du canal	0.111/0.111 dm³ (0.0039/0.0039 ft³)
Matières	Plaques en acier inoxydable 316, brasage cuivre
Poids sans les connexions	2.13+(0.1775*NoP) kg 4.69+(0.391*NoP) lb

Les dimensions standard

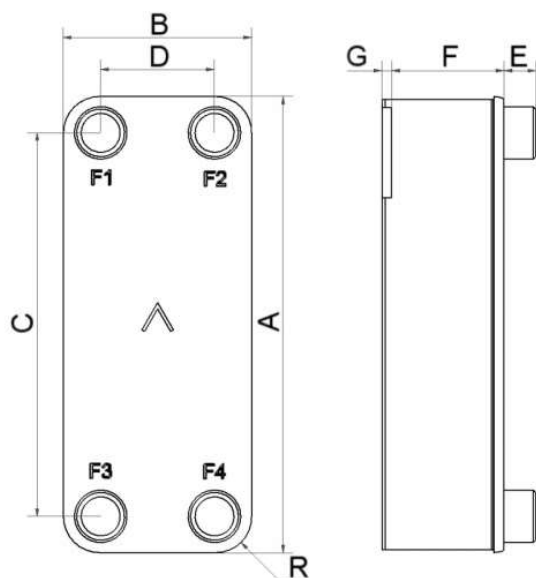

#	MM	N
A	526	20.71
B	119	4.69
C	479	18.86
D	72	2.83
F	4.00+2.25*(NoP)	0.16+0.09*(NoP)
G	6	0.24
R	23	0.91
E_1	20	0.79

PED pression / température

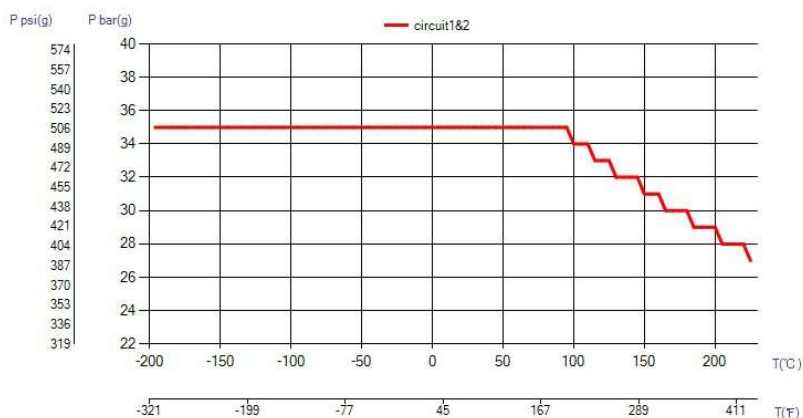

ÉCHANGEURS THERMIQUES

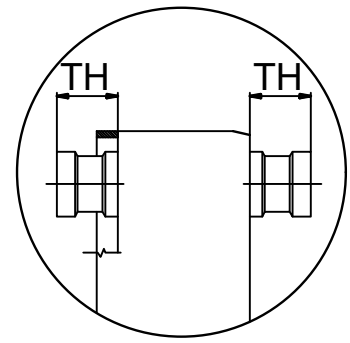
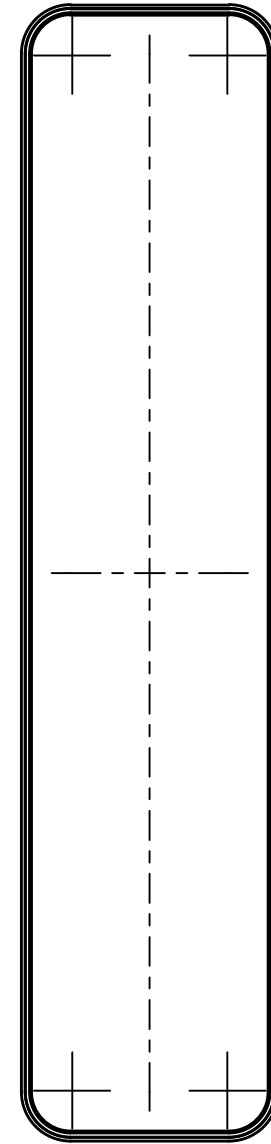
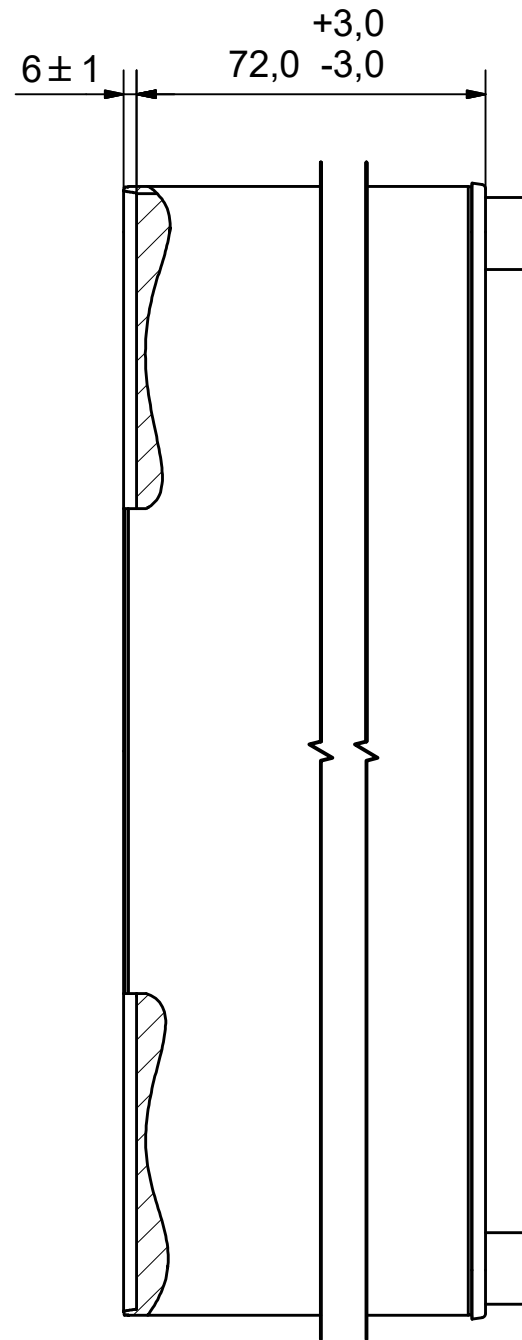
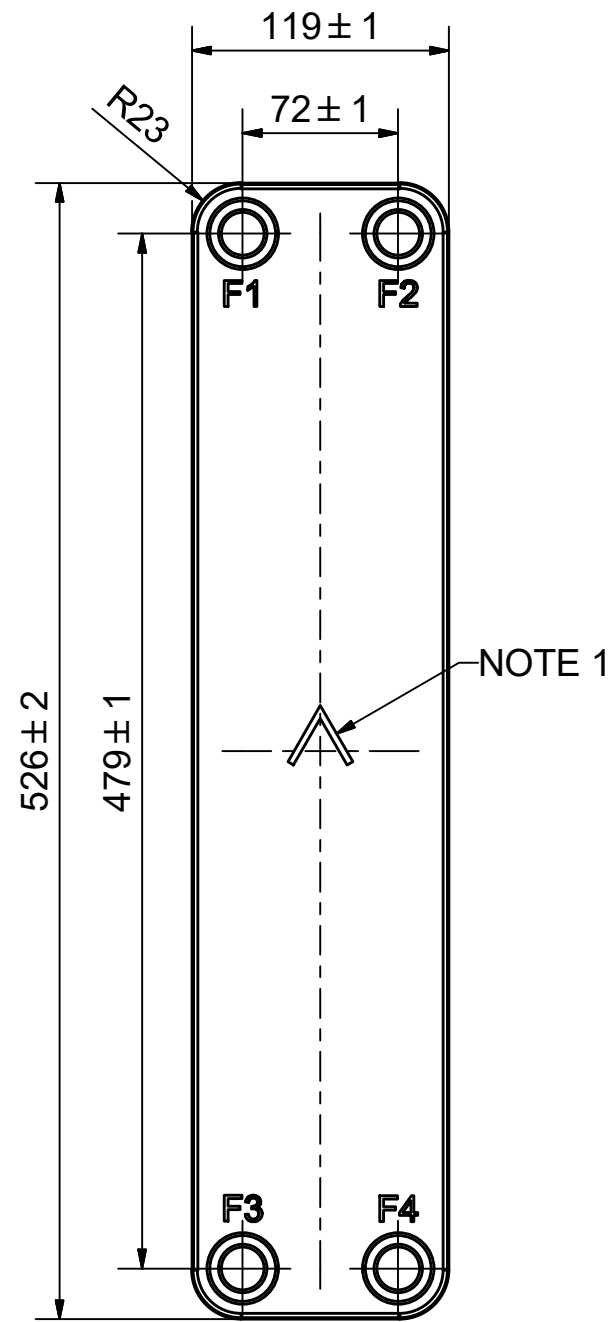

NOTE 1 ALTERNATE MARKING: STICKER OR STAMP

F4	32566	ISO-G 1" A & SOLDER 22U, TH = 20.1	CD000806
F3	32566	ISO-G 1" A & SOLDER 22U, TH = 20.1	CD000806
F2	32566	ISO-G 1" A & SOLDER 22U, TH = 20.1	CD000806
F1	32566	ISO-G 1" A & SOLDER 22U, TH = 20.1	CD000806



Title		B25TH/1P-SC-S	
Created Date		2/24/2022	Created By
Article/Configuration number		14056-030	Drawing number
			AU00684464_14056-030



Rev No.	Alteration	Date	Checked	Approved
1	CHANGED DENOMIATION	2007/05/28	ANL	PDM

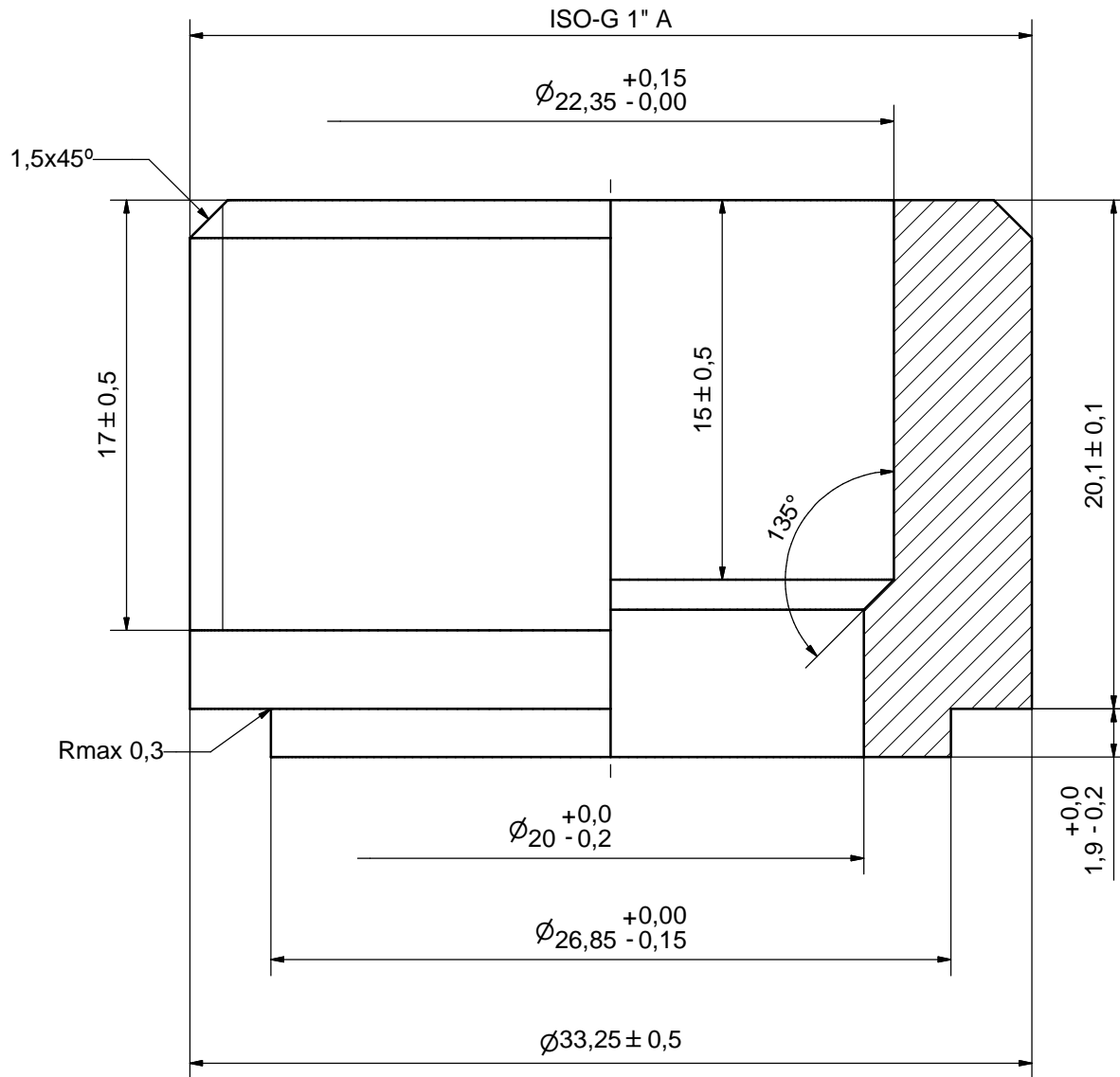
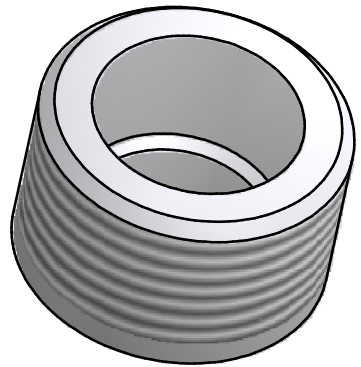

ACCORDING TO MQS
MATERIAL



Drawn	Checked	Approved	Created Date	General geometrical tolerancing ISO 2768	General surface finish R_a	Scale
THE	PDM	PDM	2006/05/09	m	3.2	5:1
Title						
ISO-G 1" A & SOLDER 22U						
Article number		Drawing number		Revision		Sheet
-		CD000806		1		1 (1)

