

B26

Intégrant des canaux AsyMatrix®, le condensateur B26 est conçu pour offrir de hautes performances, qui en font le choix idéal pour les applications de pompes à chaleur. Notre technologie AsyMatrix® combine un échangeur thermique très performant avec de faibles pertes de charge. Elle permet aux fabricants d'obtenir des systèmes à la fois plus compacts et plus efficaces. Grâce à sa haute performance, à son volume interne faible et à son encombrement réduit, ce BPHE occupe une position unique sur le marché en apportant une réponse parfaite aux besoins de nombreuses applications et fonctions.



Spécifications de base

Nombre de plaques max. (NoP)	160
Débit volumétrique max.	11,3 m ³ /h (13.21 gpm)
Volume du canal	0.044/0.066 dm ³ (0.0016/0.0023 ft ³)
Matières	Plaques en acier inoxydable 304, brasage cuivre
Poids sans les connexions	1.49+(0.1076*NoP) kg 3.29+(0.237*NoP) lb
Taille la taille des Particules (mm)	0,7

Les dimensions standard

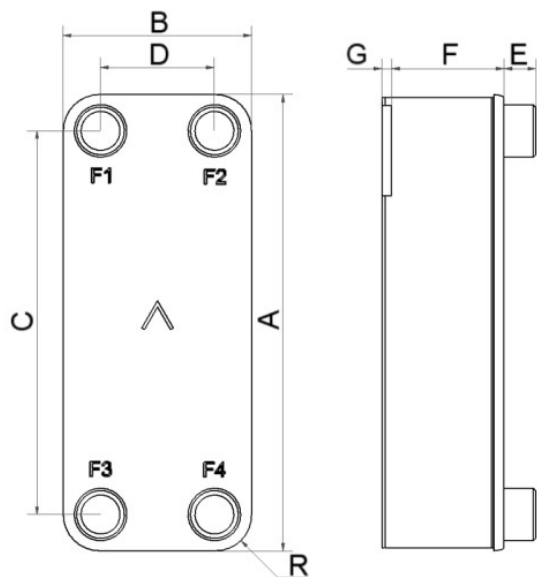

#	MM	IN
A	376	14.8
B	119	4.69
C	329	12.95
D	72	2.83
F	4,00+1,61*(NoP)	0.16+0.06*(NoP)
G	6	0.24
R	23	0.91
E_1	20	0.79
E_2	45	1.77

PED pression / température

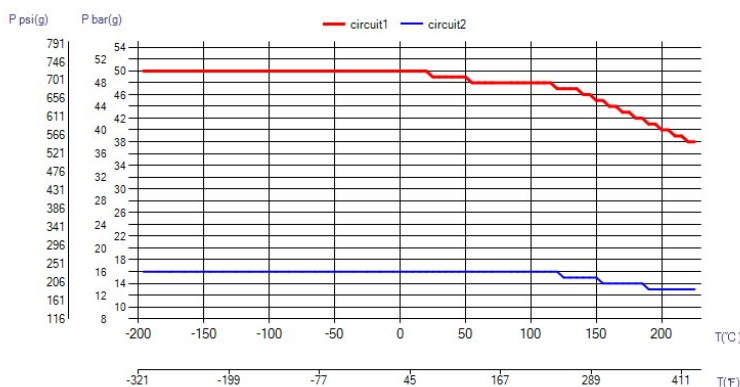

ÉCHANGEURS THERMIQUES

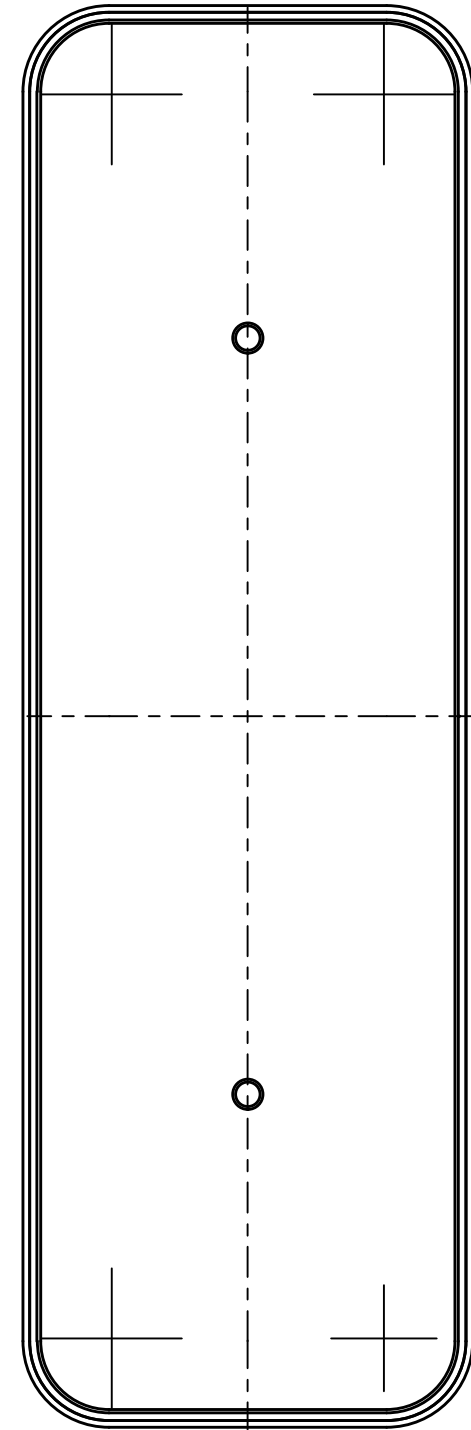
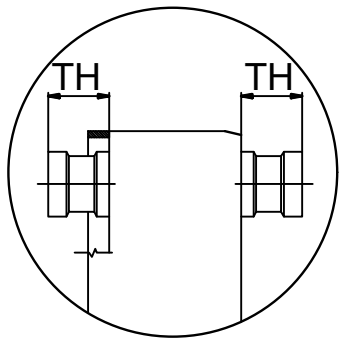
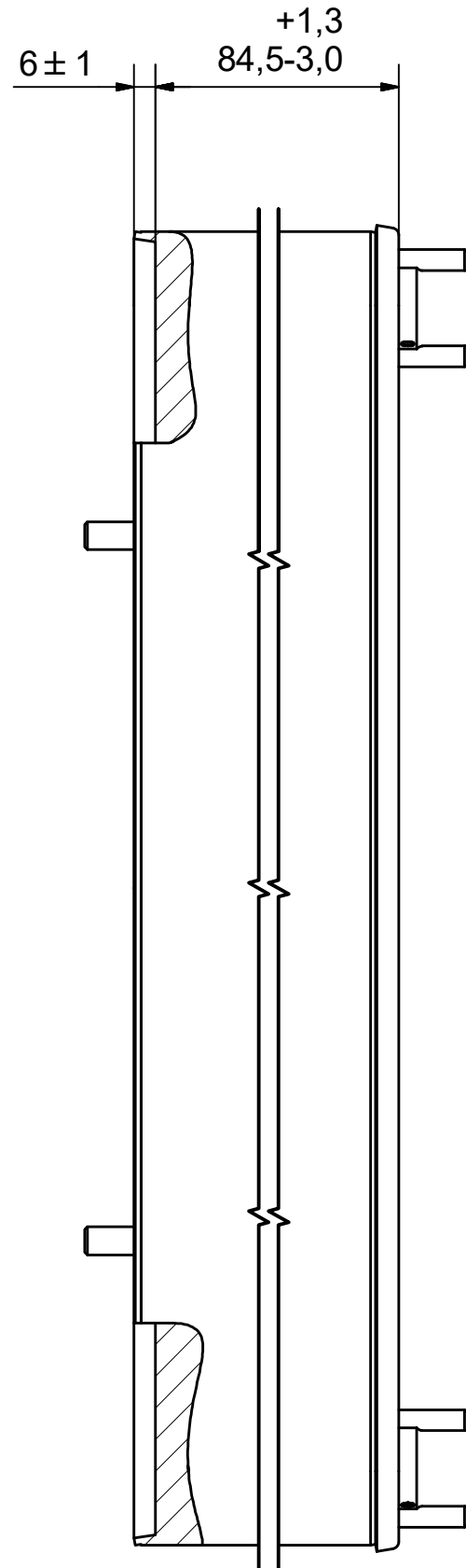
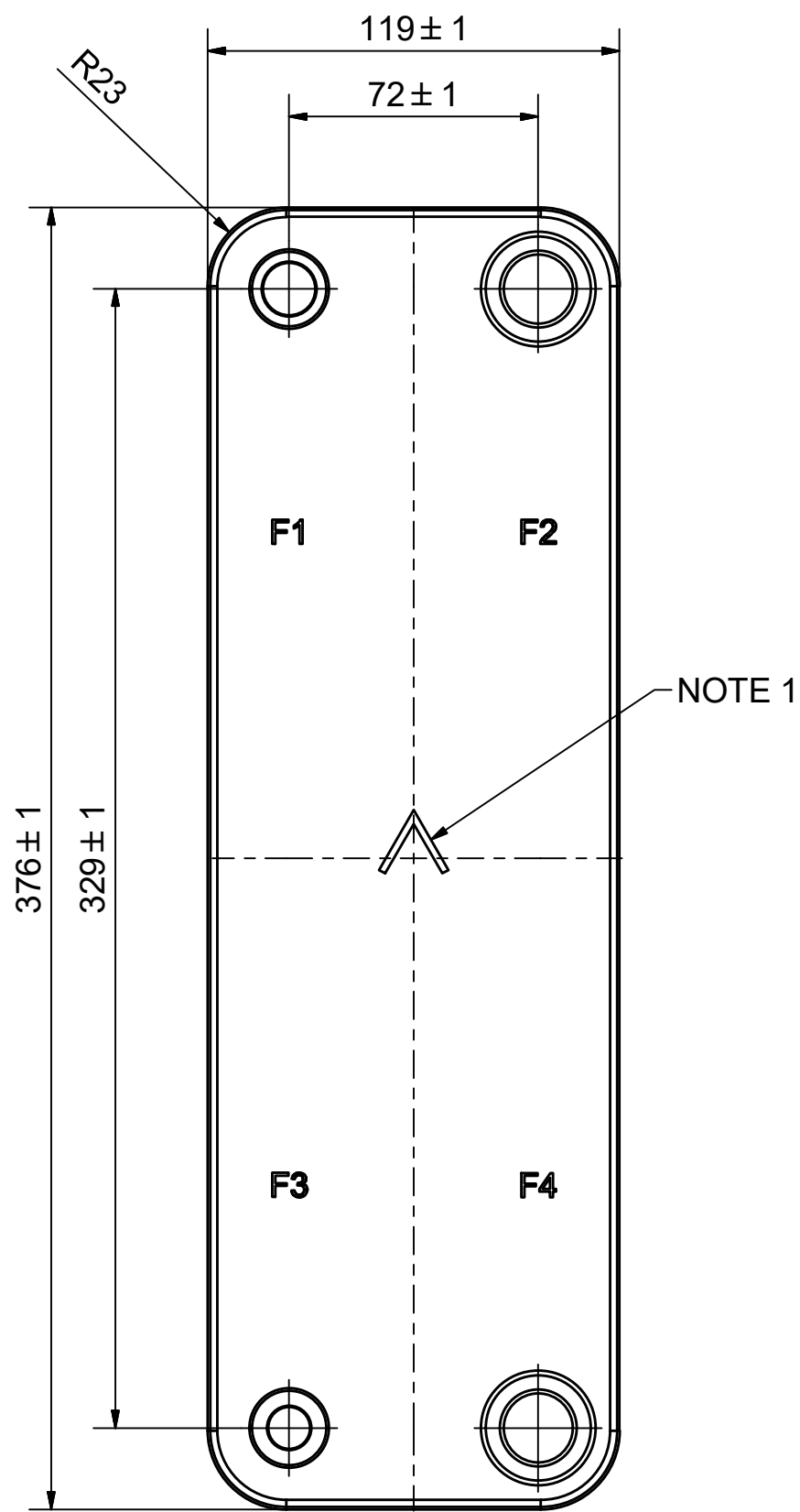

NOTE 1 ALTERNATE MARKING: STICKER OR STAMP

F4	32566	ISO-G 1" A & SOLDER 22U, TH = 20,1	CD000806
F3	41623	SOLDER $\phi 12,8$, TH = 20,1	CD001227
F2	32566	ISO-G 1" A & SOLDER 22U, TH = 20,1	CD000806
F1	41622	SOLDER $\phi 16$, TH = 20,1	CD001226
Pos	Article No	Title / Denomination, code, material, dimension etc	Drawing No./ref

P	21440	B16 STUD BOLT LOC P 2xCV200	CG160005
Pos	Article No	Title / Denomination, code, material, dimension etc	Drawing No./ref



Title B26Hx50/1P-NC-M 12.8+16+2x1" & 22U			
Created Date 2023-09-20		Created By AU	
Article/Configuration number 7000267		Drawing number AU00763848_7000267	

Rev No	Alteration	Date	Checked	Approved
03	UPDATED TITLE	5. 3. 2013	SKZE	PDM

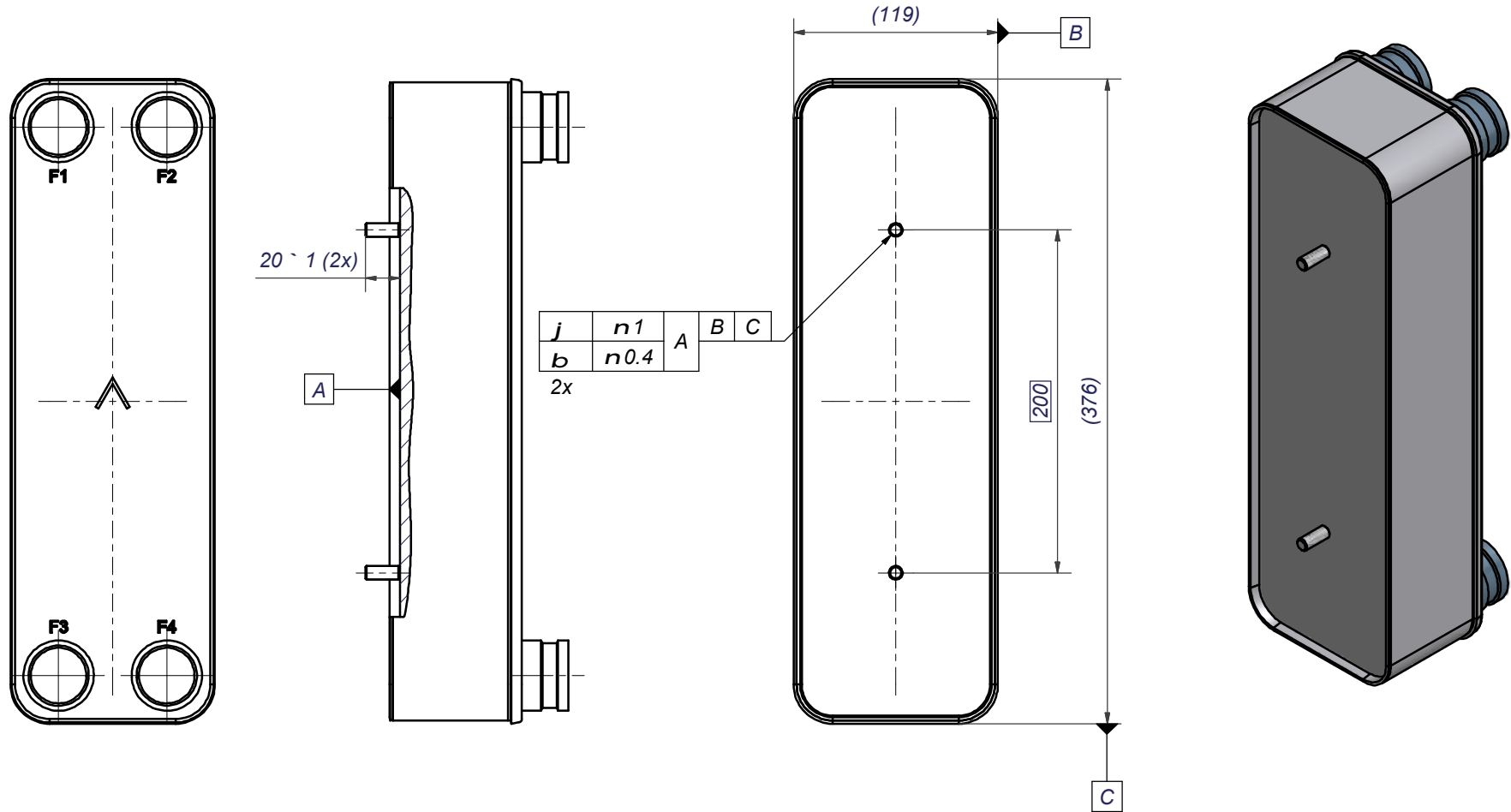

© Company Confidential. Property of SWEP International AB



1	2	STUD BOLT M8x20 ART.NO 45162				M8x20
IT	QTY	TITLE				Drawing No.
Drawn	Checked	Approved	Created Date	General geometrical tolerancing ISO 2768	General surface finish R_a	Scale
ANO	PDM	PDM	16. 5. 2005			-
		Title				Paper size
		16/26 STUD BOLT LOC P 2x200				A3
		Article / Tool number	Design Type	Drawing number	Revision	Sheet
		21440	CG	CG160005	03	1 (1)



Rev No.	Alteration	Date	Checked	Approved
1	CHANGED DENOMIATION	2007/05/28	ANL	PDM

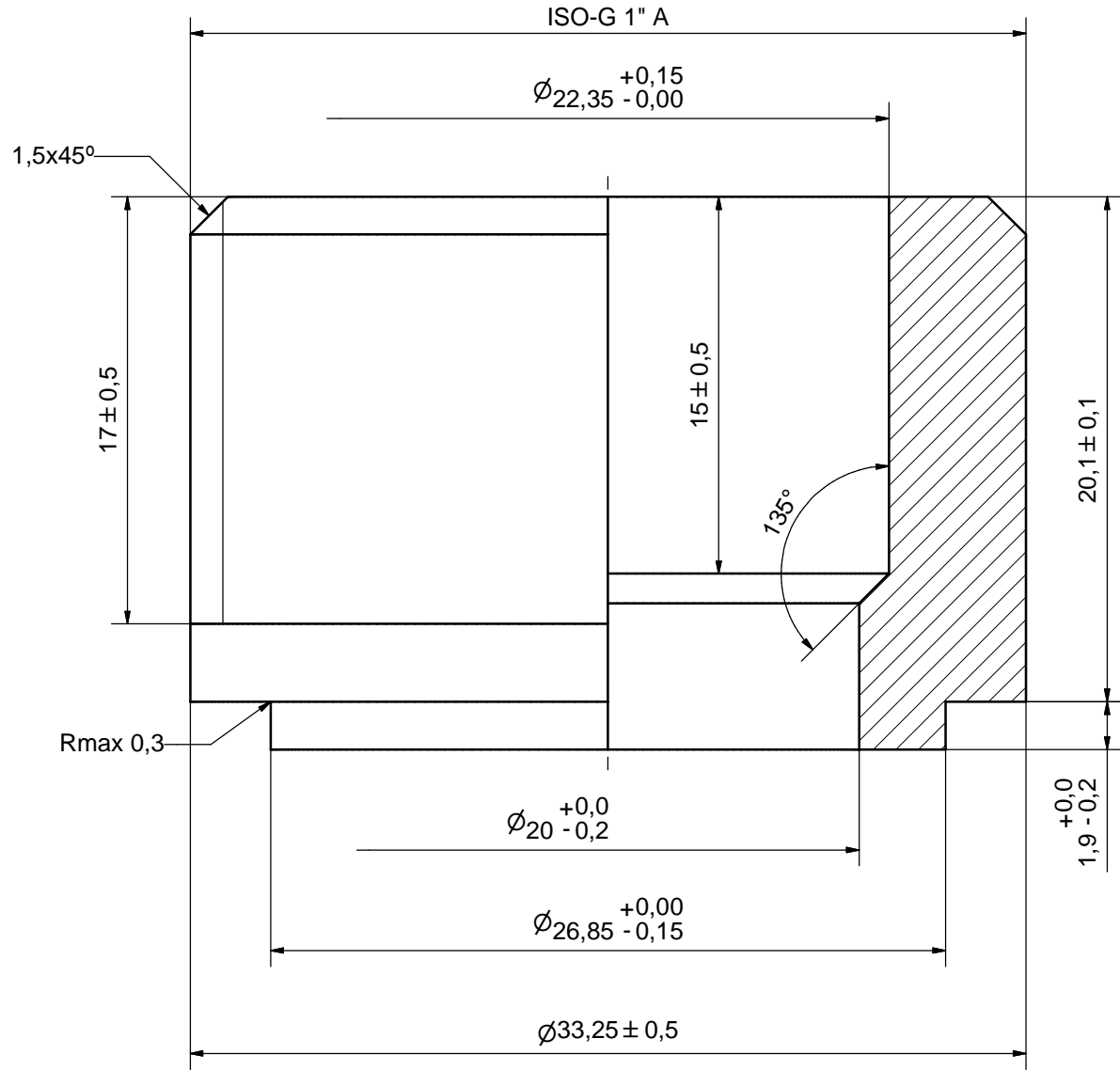
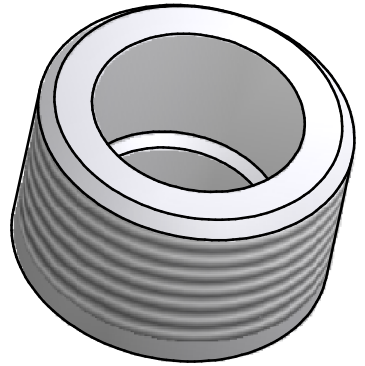

ACCORDING TO MQS
MATERIAL

AXINTRA
ÉCHANGEURS THERMIQUES

Drawn	Checked	Approved	Created Date	General geometrical tolerancing ISO 2768	General surface finish R_a	Scale
THE	PDM	PDM	2006/05/09	m	3.2	5:1
Title ISO-G 1" A & SOLDER 22U						
Article number -		Drawing number CD000806		Revision 1		Sheet 1 (1)

© Company Confidential, Property of SWEP International AB

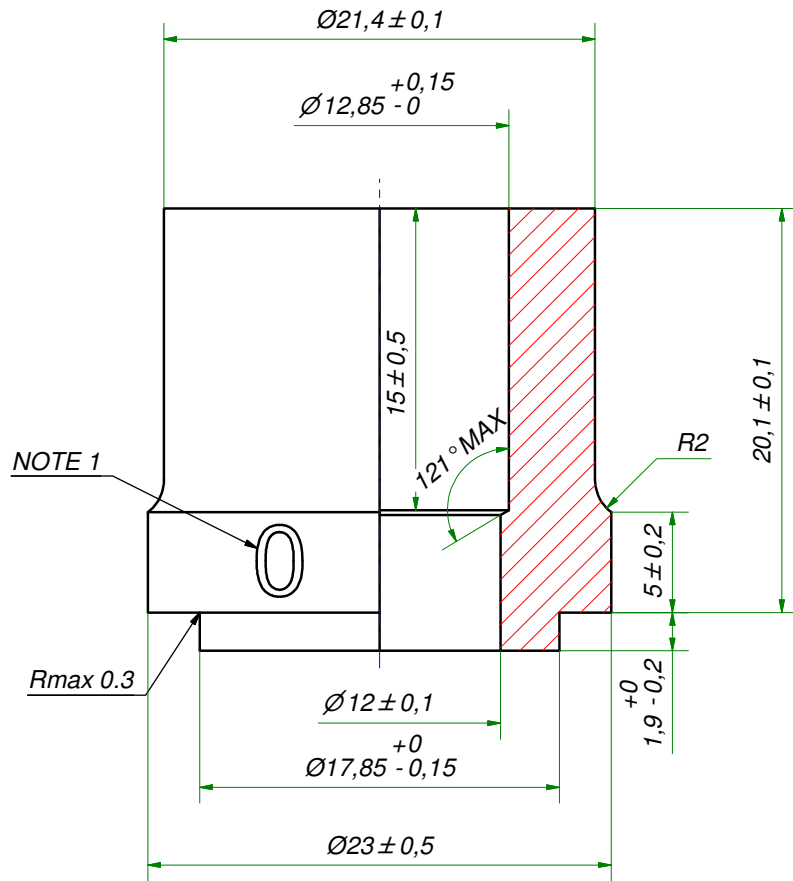

NOTE 1: MARKING TEXT "0" FOR IDENTIFICATION ONLY
PRESENT AT 2 PLACES 180° FROM EACH OTHER
"0" = 304 MATERIAL

DEBURR SHARP EDGES;MAX 0.4

ACCORDING TO MQS
Material

AXINTRA
ÉCHANGEURS THERMIQUES

Drawn	Checked	Approved	Created Date	General geometrical tolerancing ISO 2768	General surface finish R_a	Scale
SKMZP	PDM	PDM	2010-04-28	m	3.2	-
Title				SOLDER $\varnothing 12,8$		
Article number		Drawing number		Revision	Sheet	
-		CD001227		-	1 (1)	

SWEP
A DOVER COMPANY

Rev No	Alteration	Date	Checked	Approved
01	DESIGN CHANGE ACCORDING TO ECN-000158	2021-02-05	11016090	PDM

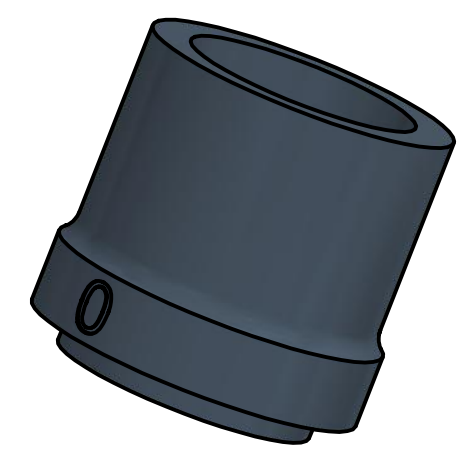
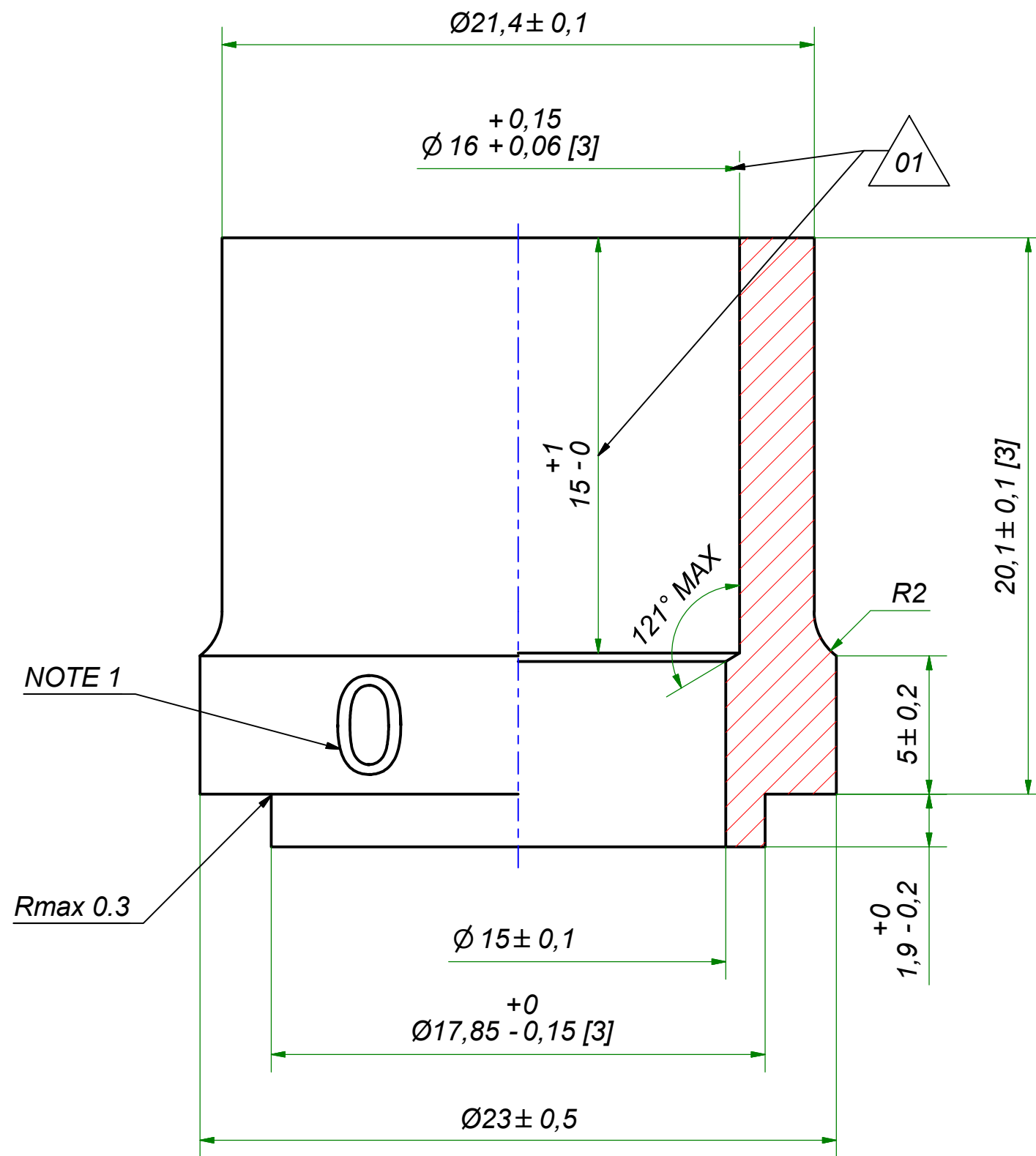

AXINTRA
ÉCHANGEURS THERMIQUES

ACCORDING TO MQS
Material

**NOTE 3: MARKING TEXT "0" FOR IDENTIFICATION ONLY
PRESENT AT 2 PLACES 180° FROM EACH OTHER
"0" = 304 MATERIAL**

NOTE 2: [3] - CRITICAL/SPECIAL CHARACTERISTIC TO BE FOLLOWED

NOTE 1: DEBURR SHARP EDGES; MAX 0.4

Drawn	Checked	Approved	Created Date	General geometrical tolerancing ISO 2768:	General surface finish R_a :	Scale	Paper size
skmzp	PDM	PDM	2010-04-28	mK	3.2	-	A3
			Title: SOLDER ø16				
			Article number	Design Type	Drawing number	Revision	Sheet
				CD	CD001226	01	1 (1)