

B320LT

Le nouveau modèle B320LT offre des solutions efficaces pour de nombreuses applications exigeantes, comme le chauffage collectif, les refroidisseurs d'huile et différentes applications industrielles. Ce produit fait partie de la nouvelle gamme SWEP avec une capacité plus élevée. Il permet une longueur thermique flexible via l'optimisation de la disposition des plaques. Il fournit une excellente intégration de l'application, combinant efficacité thermique élevée et élargissement de ses capacités.

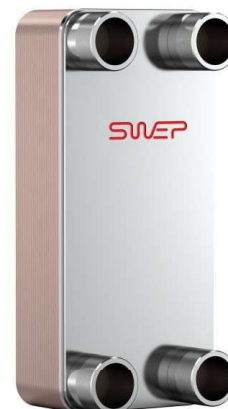

Spécifications de base

Nombre de plaques max. (NoP)	260
Débit volumétrique max.	76,2 m ³ /h (8.81 gpm)
Volume du canal	0.26/0.26 dm ³ (0.0092/0.0092 ft ³)
Matières	Plaques en acier inoxydable 316, brasage cuivre
Poids sans les connexions	9.43+(0.432*NoP) kg 20.80+(0.952*NoP) lb

Les dimensions standard

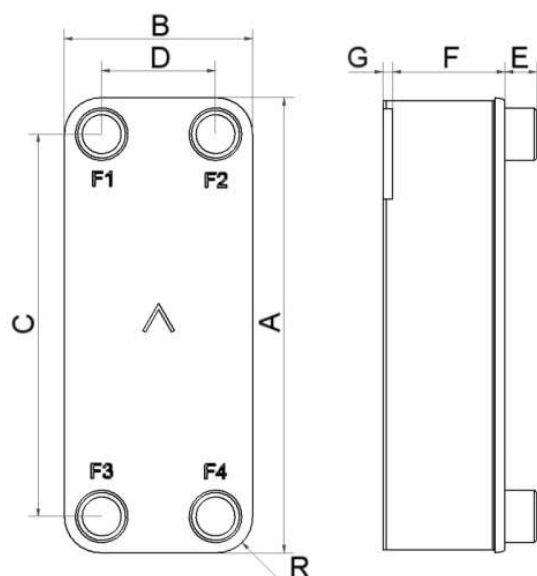

#	MM	IN
A	525	20.67
B	243	9.57
C	430	16.93
D	148	5.83
F	10.00+2.57*(NoP)	0.39+0.1*(NoP)
G	4	0.16
R	48	1.89
E_1	54	2.13

PED pression / température

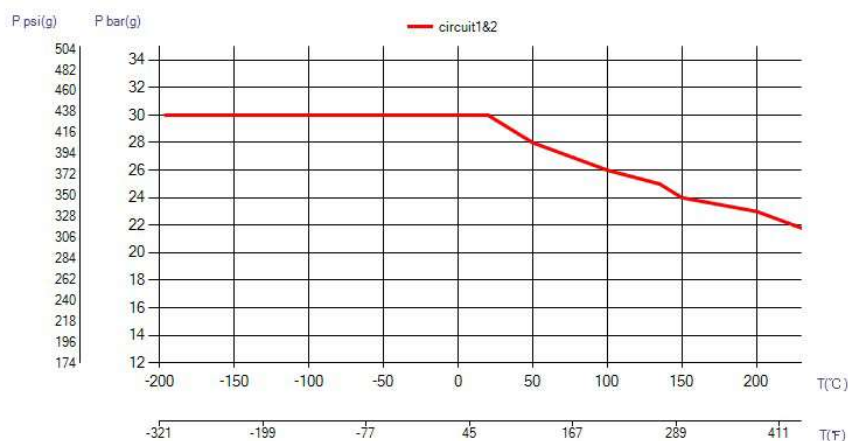

AXINTRA

ÉCHANGEURS THERMIQUES

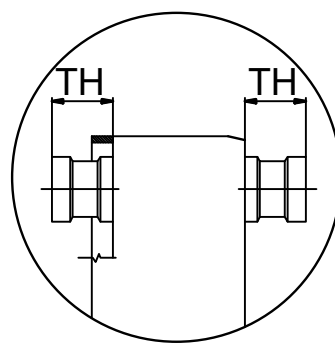
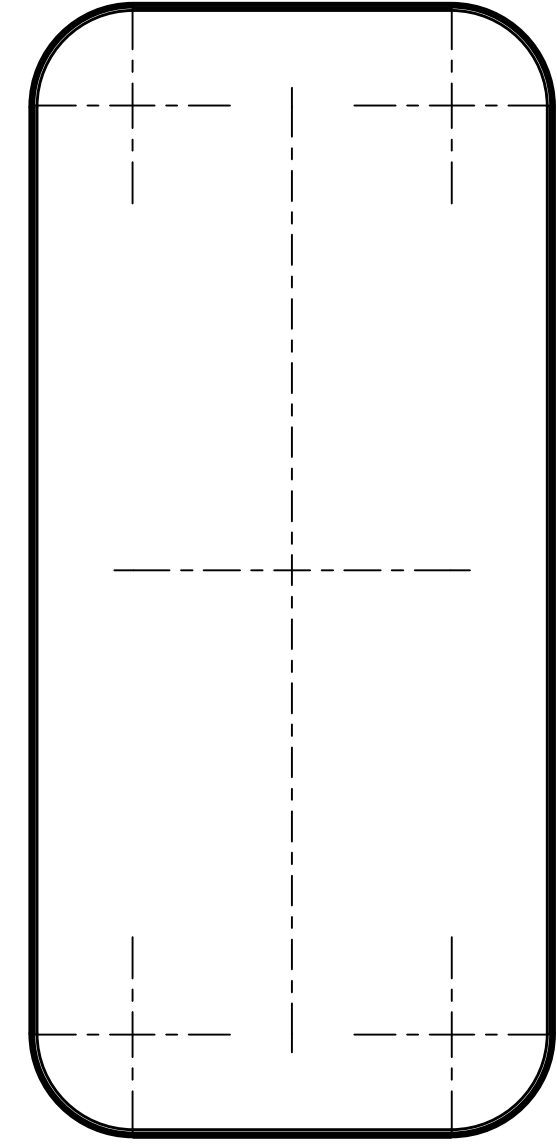
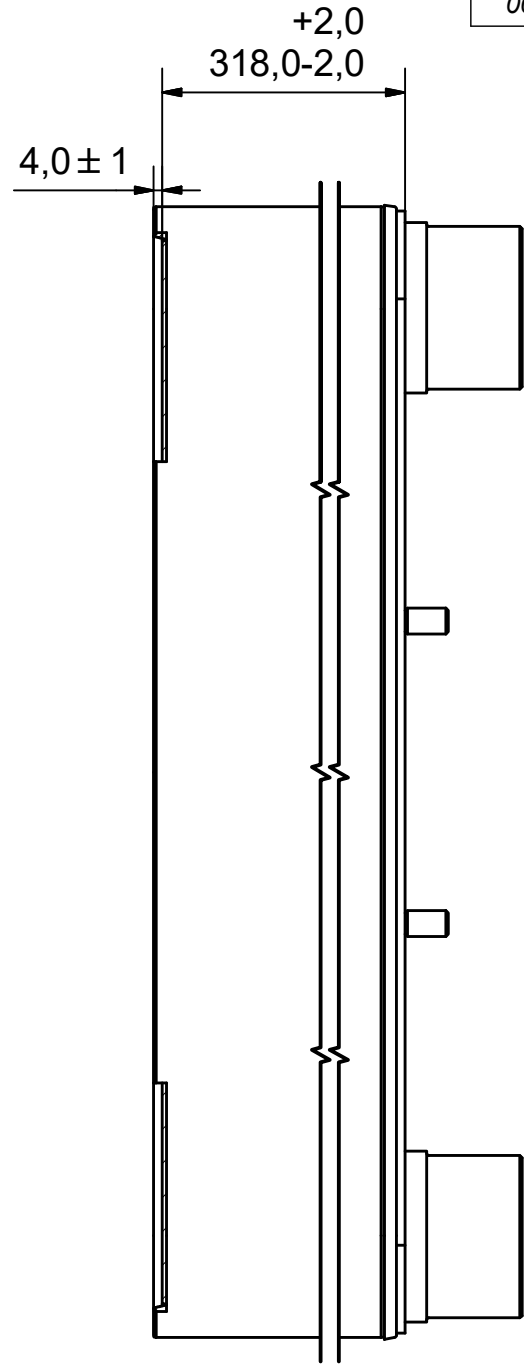
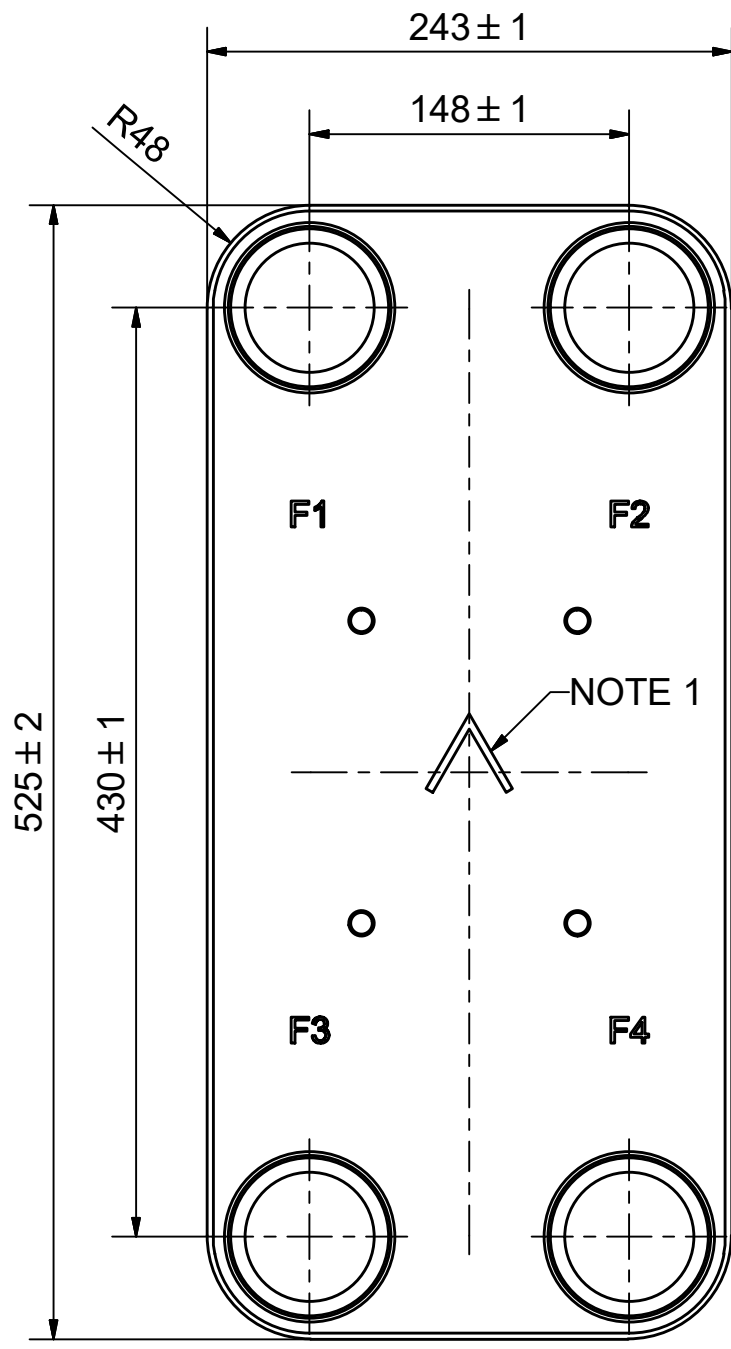

Rev No	Alteration	Date	Checked
00			



AXINTRA
ÉCHANGEURS THERMIQUES

NOTE 1 ALTERNATE MARKING: STICKER OR STAMP

F4	46090	ISO-G 2 1/2 , TH = 54,2	CD000288
F3	46090	ISO-G 2 1/2 , TH = 54,2	CD000288
F2	46090	ISO-G 2 1/2 , TH = 54,2	CD000288
F1	46090	ISO-G 2 1/2 , TH = 54,2	CD000288
F	21118	B120T/50 BOLT LOC F 4x C140x100	CG450024_1

Title		B320LTH/1P-SC-S	
 A DOVER COMPANY	Created Date	Created By	
	2020-06-09	AU	
Article/Configuration number		Drawing number	
19122-120		AU00579022	

Pos	Article No	Title / Denomination, code, material, dimension etc	Drawing No./ref	Pos	Article No	Title / Denomination, code, material, dimension etc	Drawing No./ref
-----	------------	---	-----------------	-----	------------	---	-----------------

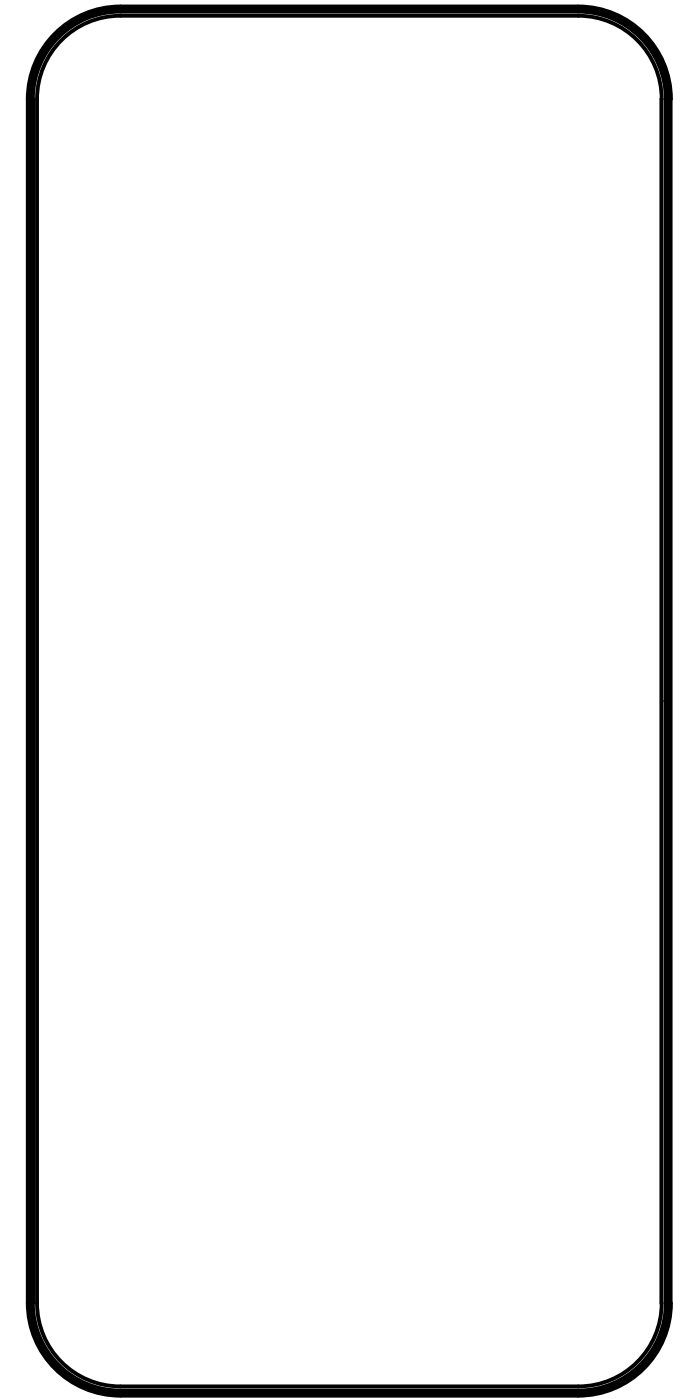
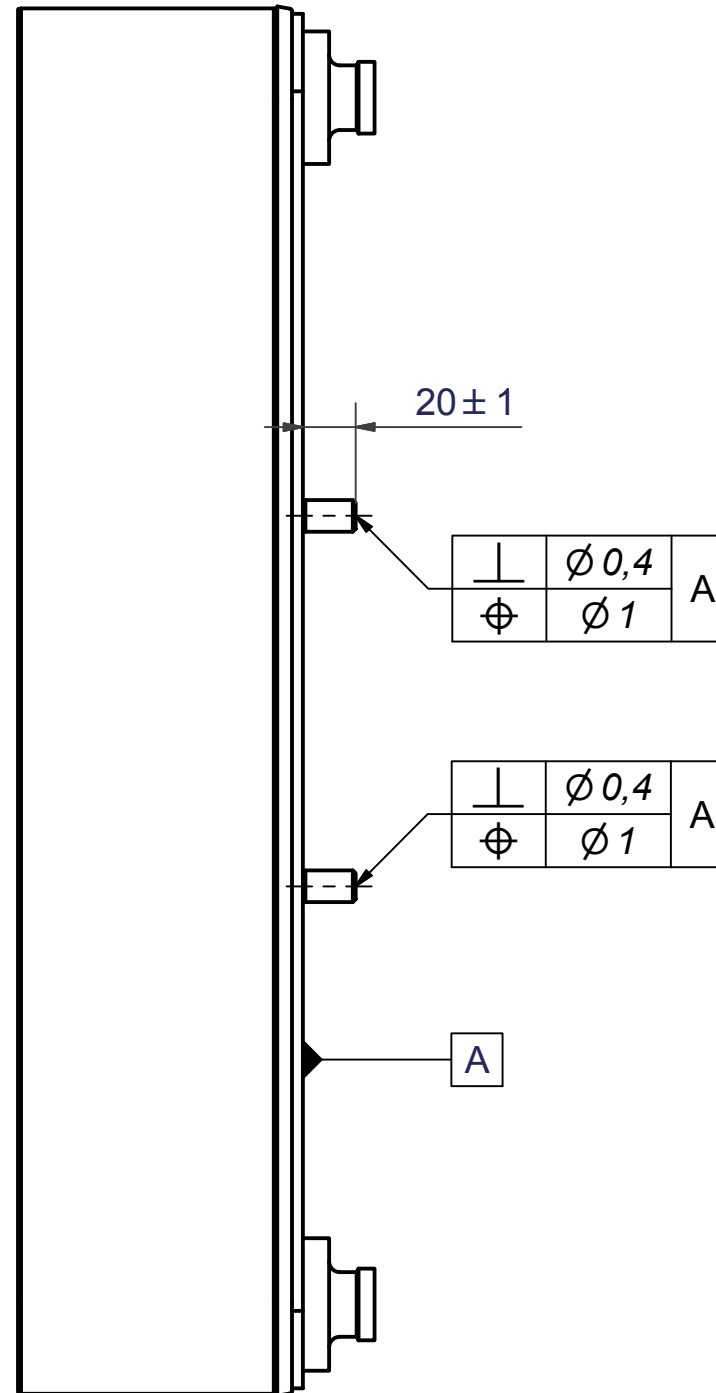
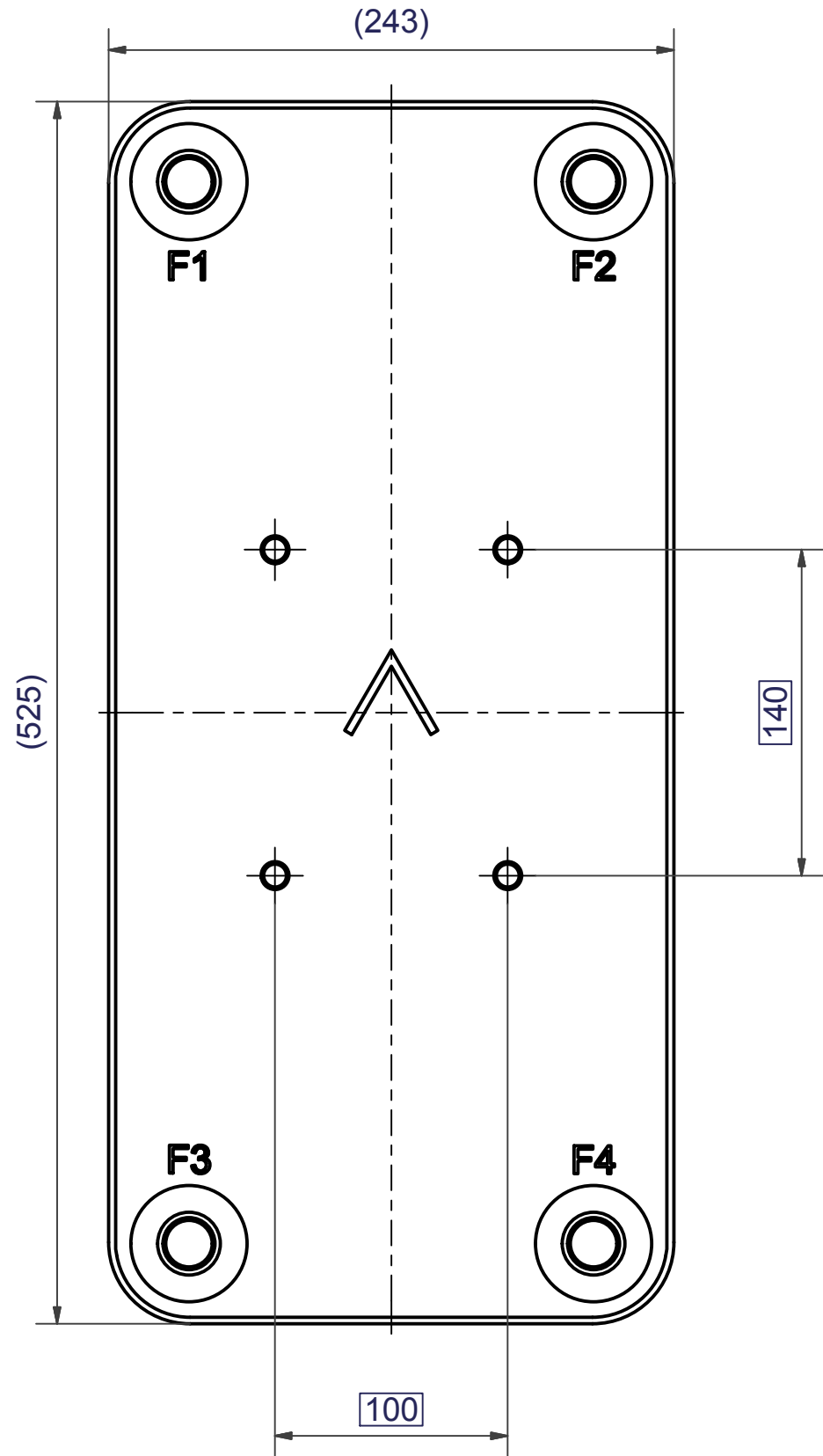

1	4	STUD BOLT M12x20 ART. NO. 45095	M12x20
IT	QTY	DESCRIPTION	Drawing No./Ref
lathe	PDM	PDM	2004-10-12
		General geometrical tolerancing ISO 2768: m	General surface finish R _a : 3.2
		Scale: 1:1	
		B120T/50 BOLT LOC F 4x C140x100	
		Article number: 21118	Drawing number: CG450024
		Revision: 00	Sheet: 1 (1)

Rev No.	Alteration	Date	Checked	Approved
4	ADDED DEBURR AND MATERIAL INFO	2009/08/06	RJ	PDM

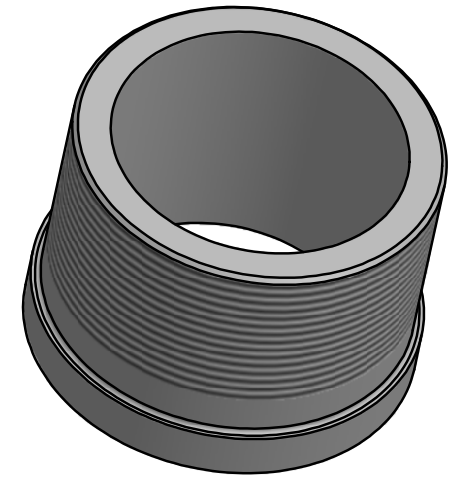
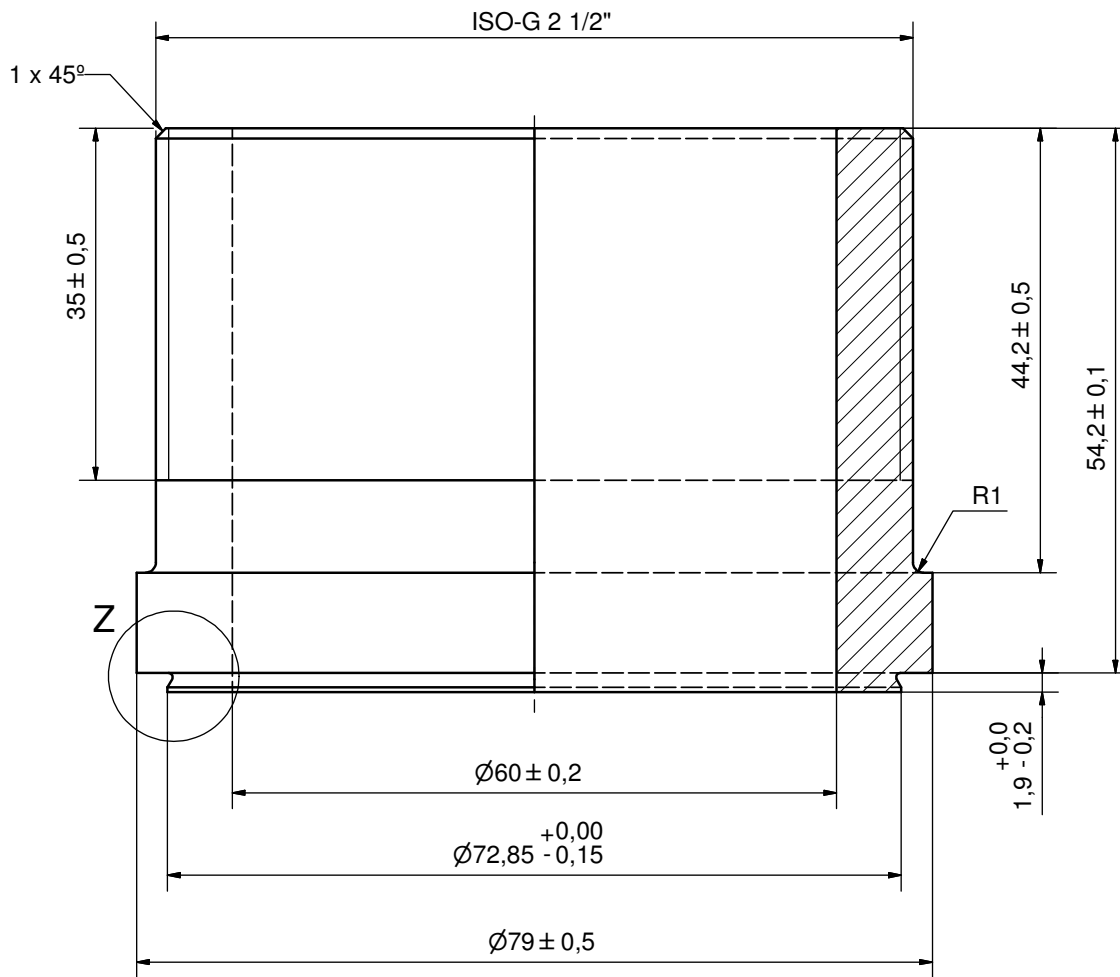

Z (8 : 1)

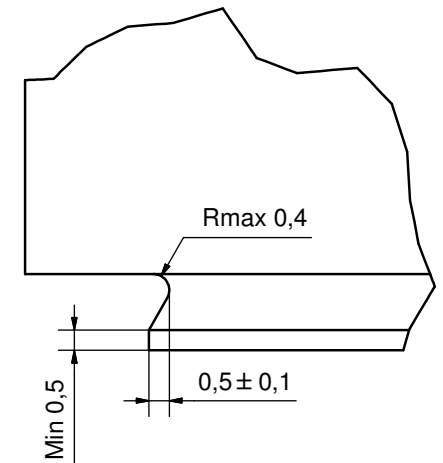

DEBURR SHARP EDGES; MAX 0.4

ACCORDIN TO MQS

MATERIAL

Drawn	Checked	Approved	Created Date	General geometrical tolerancing ISO 2768	General surface finish Ra	Scale
EG	TOD	BOS	1997-02-17	m	3.2	-
			ISO-G 2 1/2			
Article number		Drawing number		Revision	Sheet	
-		CD000288		4	1 (1)	