

Rev No	Alteration	Date	Checked	Approved
05	Added 320 size to NOTE 1.	2018-06-12	SKDS	PDM

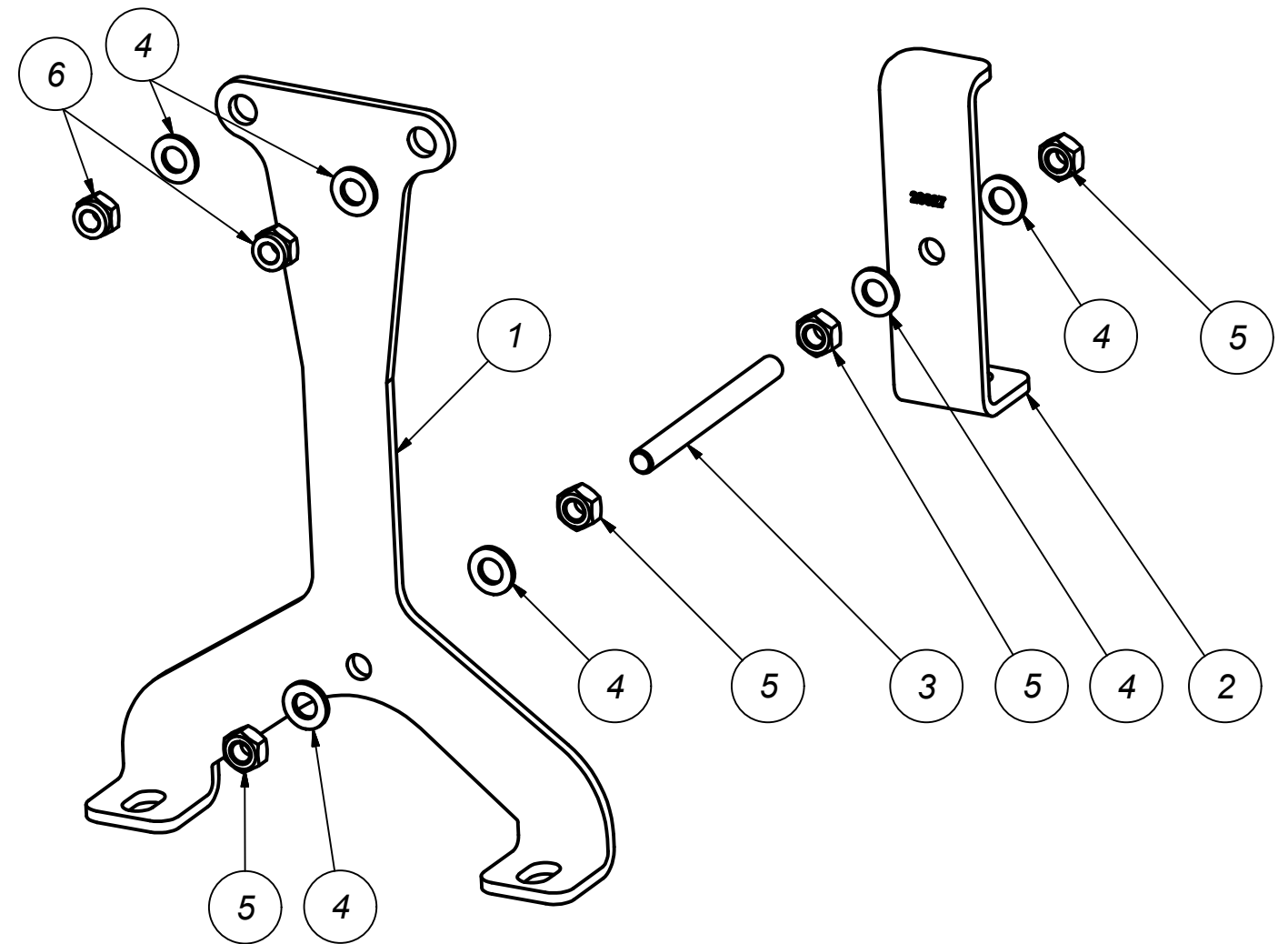

NOTE 3: LENGTH OF THREADED BAR ACCORDIN DRAWING.
NOTE 2: FOR B57 WITH STD Conn. STUD BOLT 21235 IS REQUIRED.
NOTE 1: REQUIRES STUD BOLT 21118, 21120 (B50, B56, B200, 120T, 220, 320LT, 320HT).

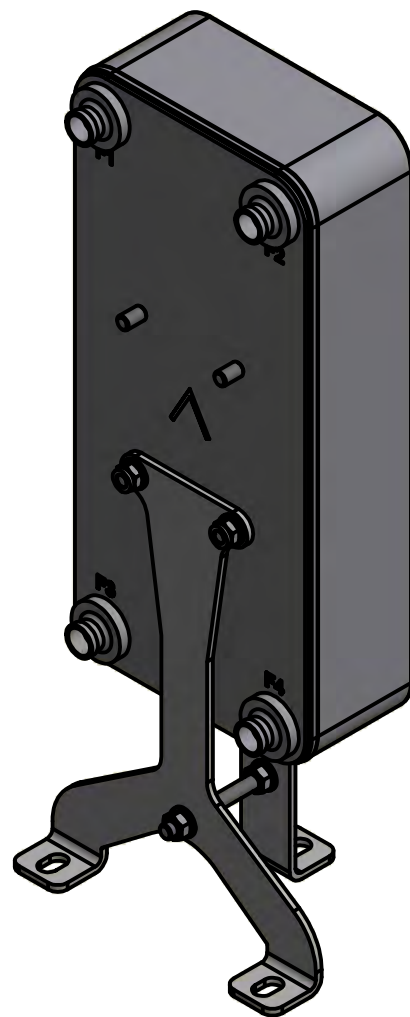
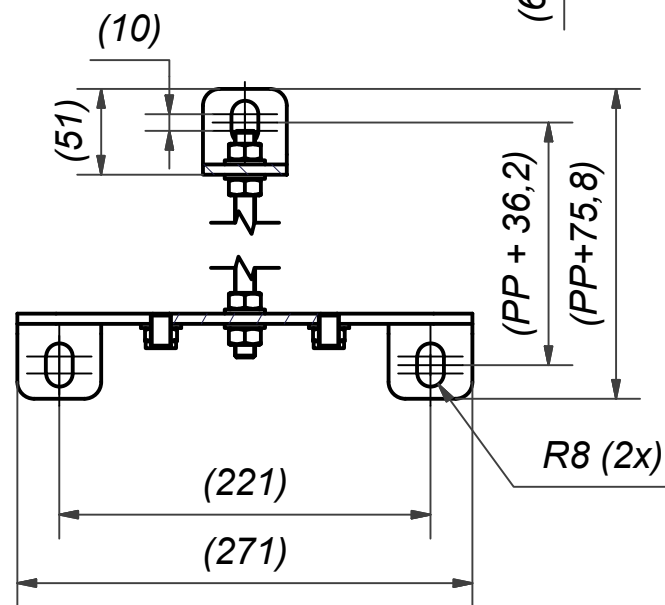
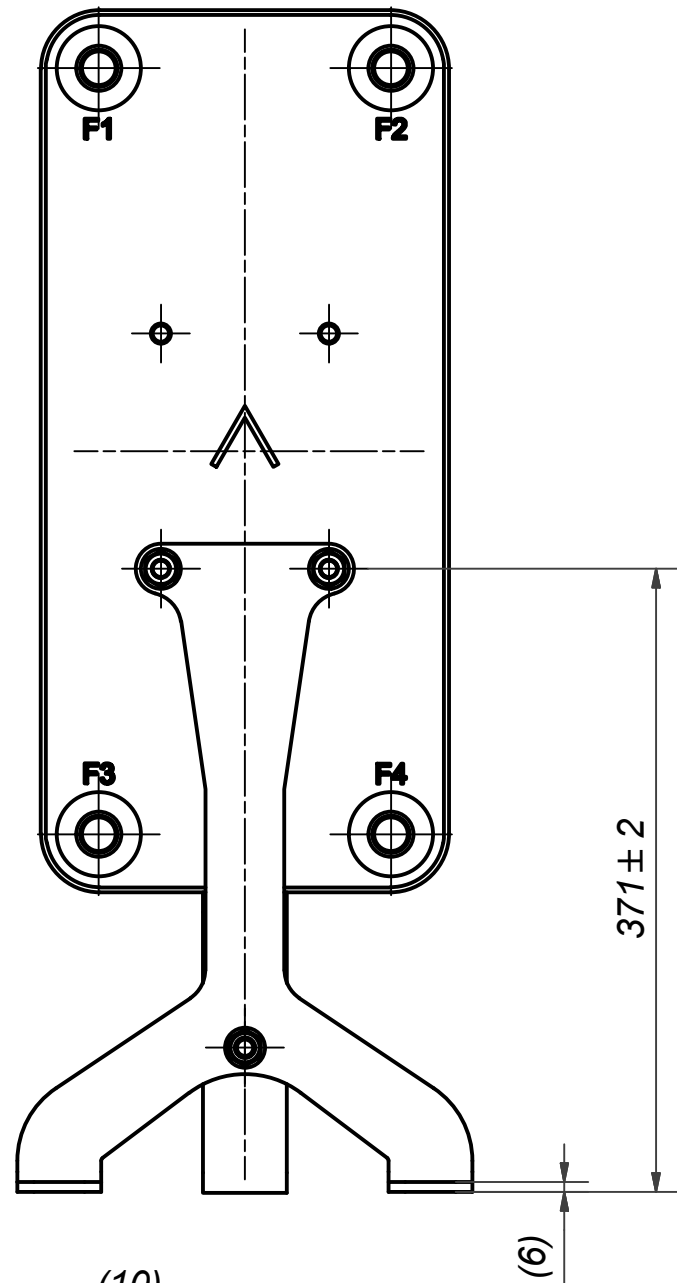
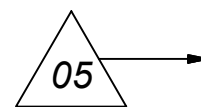

ITEM	QTY	TITLE	Drawing No.
6	2	R-LOCKNUT M12 A2, 45523	DIN 985 - M12
5	4	NUT M12 M6M 8M FZB, 45889	DIN 934 - M12
4	6	WASHER ART. NO 45524	13x24x2.5
3	1	THREADED BAR M12	CC000168
2	1	B35/45/50/57 SUPPORT LEG. ART.NO.28027	CC000165
1	1	B45/50/57 SUPPORT LEG, ART.NO. 28029	CC000167

Drawn	Checked	Approved	Created Date	General geometrical tolerancing ISO 2768	General surface finish R_a	Scale	Paper size
lathe	PDM	PDM	2005-07-27			-	A3

SWEET		B120/50/57 SUPPORT LEG			
Article / Tool number	Design Type	Drawing number	Revision	Sheet	
0	CG	CG450025	05	1 (1)	