

# B35T

Le B35T est le produit idéal pour de nombreuses applications : chauffage urbain, récupération de chaleur, cogénération, refroidissement d'huile de transmission et de moteur. Il est le choix parfait pour bénéficier de transferts de chaleur efficaces et de faibles pertes de charges dans des systèmes de conduites jusqu'à 2 pouces et des débits d'eau jusqu'à 27 m<sup>3</sup>/h (118.8 gpm).



## Spécifications de base

Nombre de plaques max. (NoP)	260
Débit volumétrique max.	58 m <sup>3</sup> /h (255.37 gpm)
Volume du canal	0.18/0.18 dm <sup>3</sup> (0.0064/0.0064 ft <sup>3</sup> )
Matières	Plaques en acier inoxydable 316, brasage cuivre
Poids sans les connexions	6.96+(0.247*NoP) kg 15.35+(0.545*NoP) lb

## Les dimensions standard

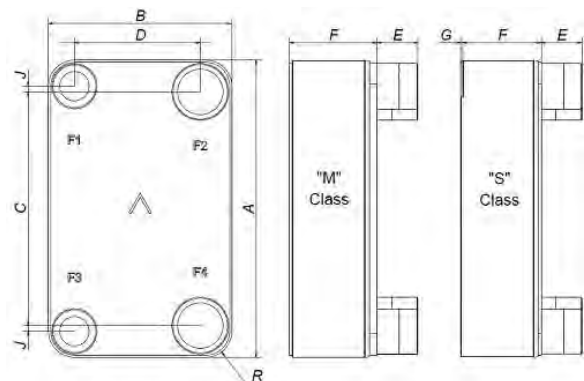

#	MM	IN
A	393	15.47
B	243	9.57
C	309	12.17
D	159	6.26
F	10.00+2.26*(NoP)	0.39+0.09*(NoP)
G	4	0.16
R	35	1.38
E_1	27	1.06

## PED pression / température

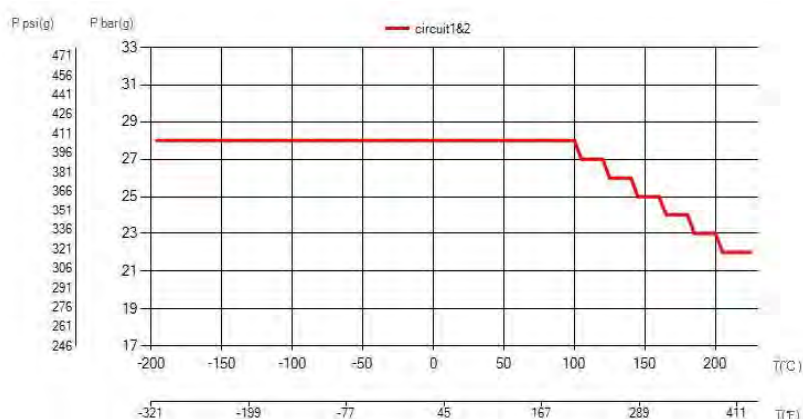

**AXINTRA**

ÉCHANGEURS THERMIQUES

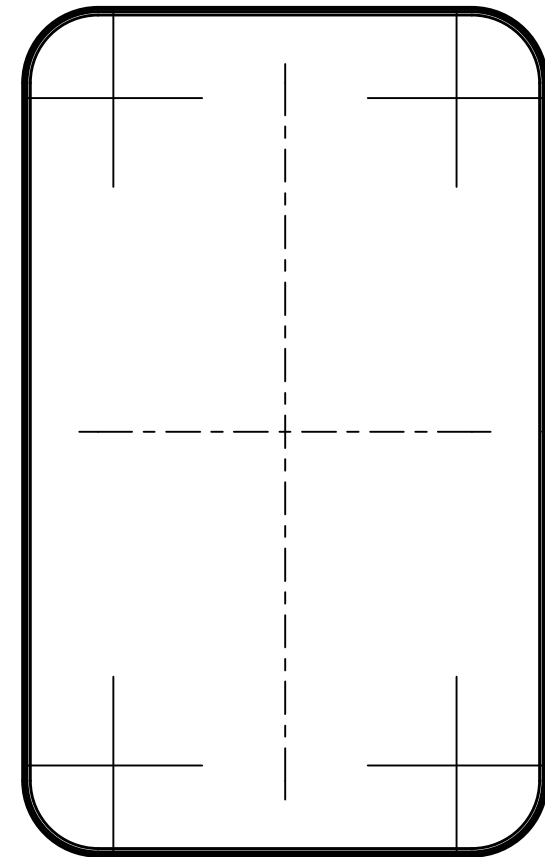
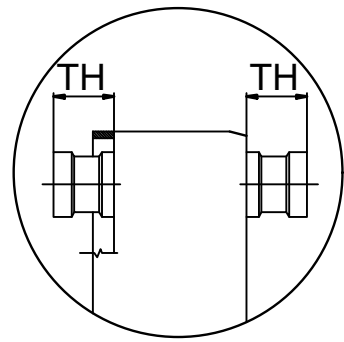
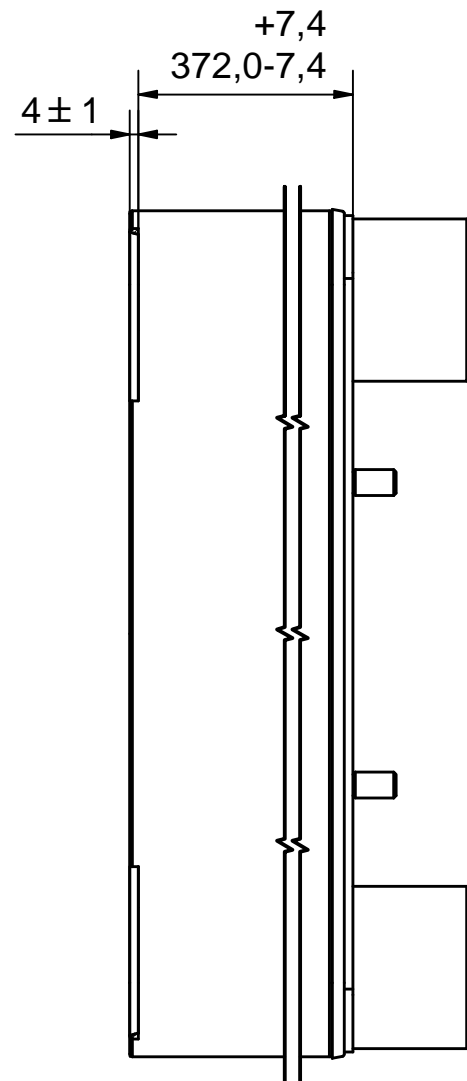
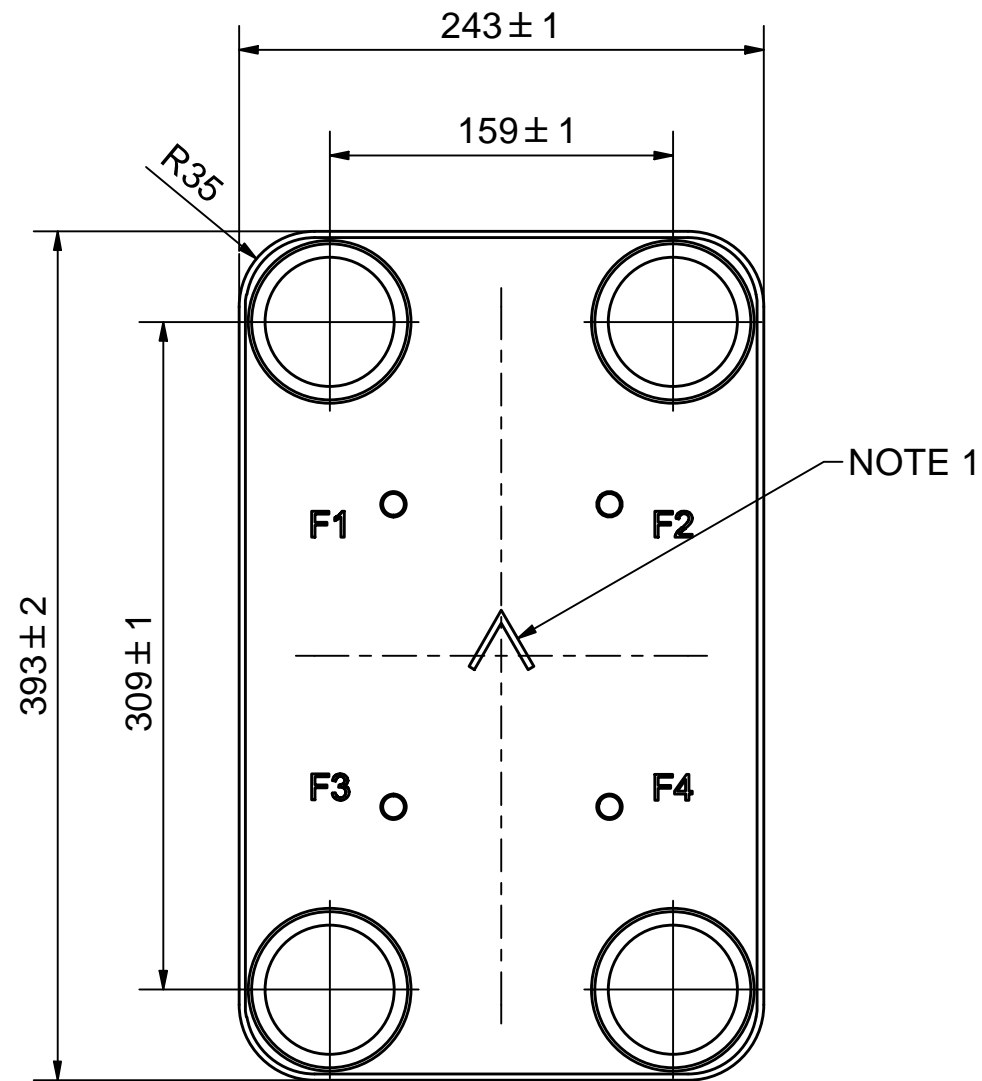



**AXINTRA**  
ÉCHANGEURS THERMIQUES

NOTE 1 ALTERNATE MARKING: STICKER OR STAMP

F4	45311	ISO-G 2 1/2 A, TH = 54,2	CD000051
F3	45311	ISO-G 2 1/2 A, TH = 54,2	CD000051
F2	45311	ISO-G 2 1/2 A, TH = 54,2	CD000051
F1	45311	ISO-G 2 1/2 A, TH = 54,2	CD000051
F	21112	B35 BOLT LOC F 4x C140x100	CG350001_1

Pos	Article No	Title / Denomination, code, material, dimension etc	Drawing No./ref	Pos	Article No	Title / Denomination, code, material, dimension etc	Drawing No./ref
-----	------------	---	-----------------	-----	------------	---	-----------------

Title		B35TM4/1P-SC-S	
 A DOVER COMPANY	Created Date	Created By	
	2024-07-16	AU	
	Article/Configuration number	Drawing number	
	16106-160	AU00053484_16106-160	

Rev No.	Alteration	Date	Checked	Approved
2	REDRAWN IN INVENTOR	2004/12/10	PDM	PDM

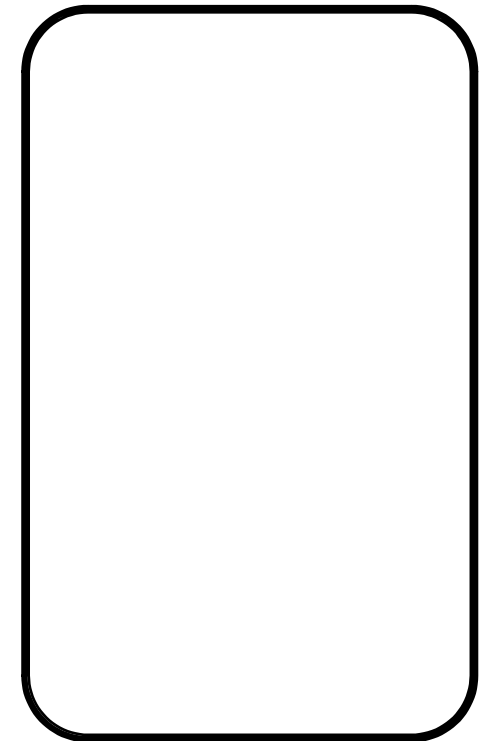
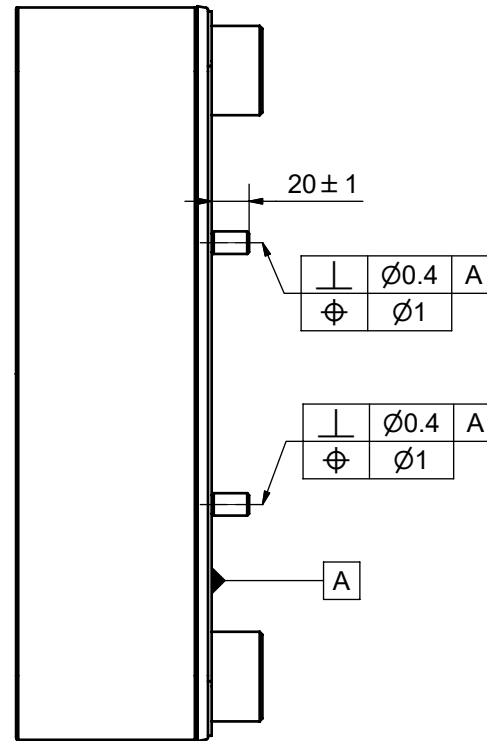
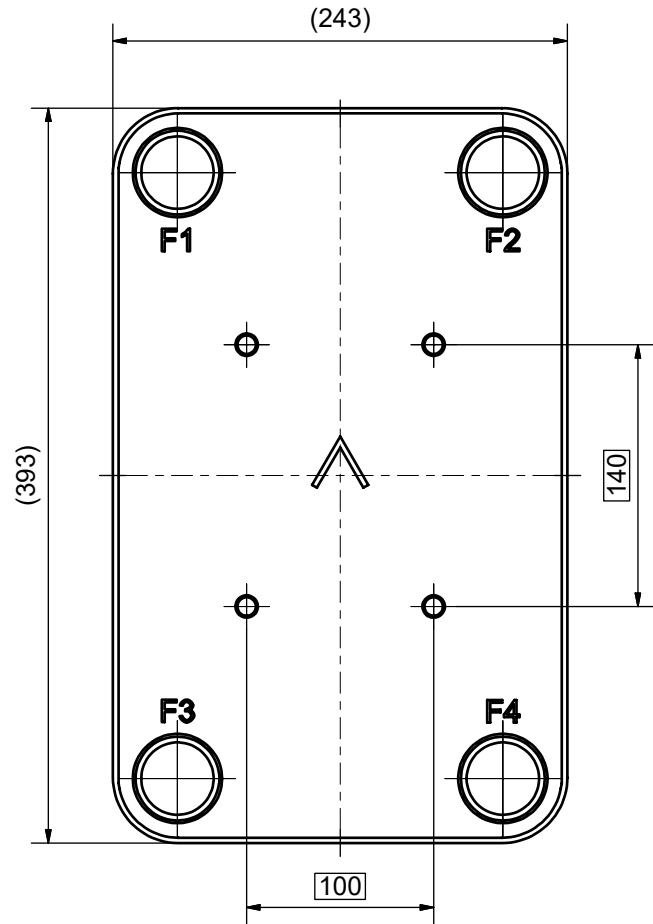

© Company Confidential, Property of SWEP International AB

1	4	STUD BOLT M12 x 20, ART. NO. 45095				M12 x 20
ITE	QTY	DESCRIPTION				Drawing No.
Drawn	Checked	Approved	Created Date	General geometrical tolerancing ISO 2768	General surface finish $R_a$	Scale
JA	PDM	PDM	2004/10/12	m	3.2	1:1
		Title				
		B35 BOLT LOC F 4x C140x100				
		Article number	Drawing number	Revision	Sheet	
		21112	CG350001	2	1 (1)	

Rev No	Alteration	Date	Checked	Approved
09	ECN-000161: Groove (Detail Z), [3] for crit. char., no zero mark	2021-01-28	SKGL	VP

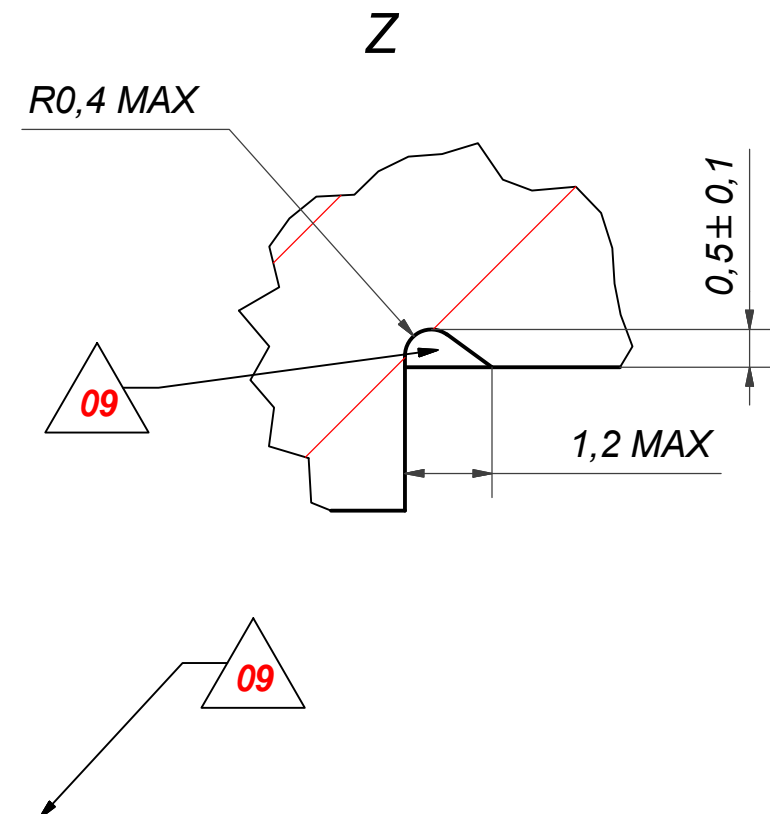
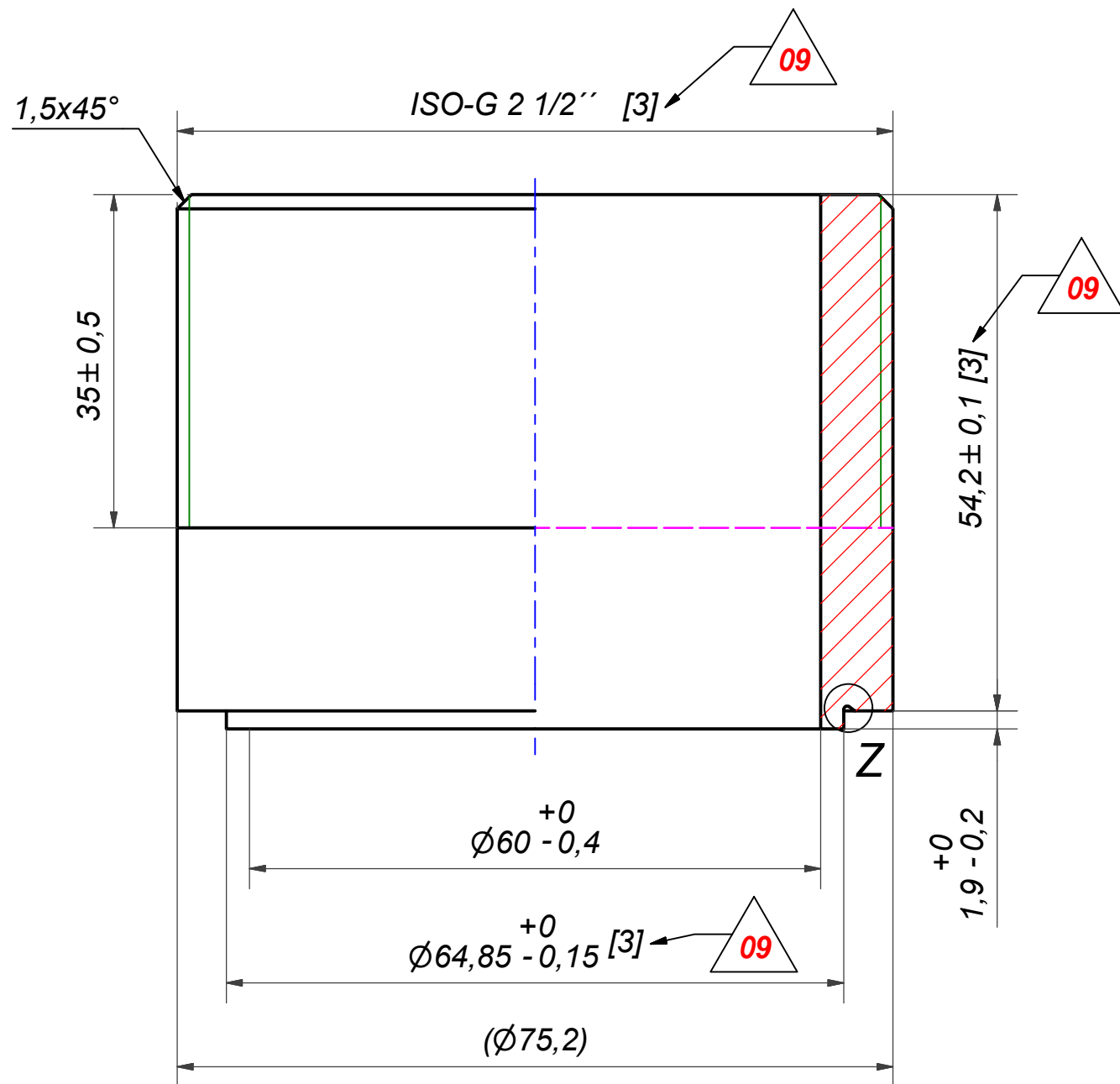

**NOTE 2: [3] - CRITICAL/SPECIAL CHARACTERISTIC TO BE FOLLOWED**  
**NOTE 1: DEBURR SHARP EDGES; MAX 0.4**

ACCORDING TO MQS  
MATERIAL

Drawn miguser	Checked TP	Approved VP	Created Date 1991-03-15	General geometrical tolerancing ISO 2768: m	General surface finish $R_a$ : 3.2	Scale -	Paper size A3
			Title ISO-G 2 1/2				
			Article number CD	Design Type CD	Drawing number CD000051	Revision 09	Sheet 1 (1)